

# TECHNICAL MANUAL

## UNIT AND DIRECT SUPPORT (DS) MAINTENANCE MANUAL (INCLUDING REPAIR PARTS AND SPECIAL TOOLS LIST) FOR

PARACHUTE, CARGO TYPE:

28-FOOT DIAMETER, CARGO  
EXTRACTION PARACHUTE ASSEMBLY

NSN 1670-00-040-8135

**DISTRIBUTION STATEMENT A:** Approved for public release; distribution is unlimited.  
\*This manual supercedes TM 10-1670-277-23&P, dated 9 October 1990

**THIS PAGE INTENTIONALLY LEFT BLANK**

## WARNING SUMMARY

This warning summary contains general safety warnings and hazardous material warnings that must be understood and applied during operation and maintenance of this equipment. Failure to observe these precautions could result in serious injury or death to personnel.

---

### WARNING

---

For first aid treatment, refer to FM 4-25.11.

---

### WARNING

---

Exercise extreme care when using petroleum products to destroy equipment by fire, as these materials are highly flammable. Improper handling may cause injury to personnel.

---

### WARNING

---

Failure to detect areas of damage may result in malfunction of the parachute or loss of equipment.

**THIS PAGE INTENTIONALLY LEFT BLANK**

INSERT LATEST UPDATED PAGES/WORK PACKAGES, DESTROY SUPERSEDED DATA

## LIST OF EFFECTIVE PAGES

DATE OF ISSUE FOR ORIGINAL IS: 30 APRIL 2002

### NOTE

The portion of text affected by the update is indicated by a vertical line in the outer margins of the page. Updates to illustrations are indicated by miniature pointing hands.

**Total number of pages for front and rear matter is 30. The total number of work packages is 66, consisting of the following:**

<b>Page/Work Package No.</b>	<b>*Change No.</b>	<b>Page/Work Package No.</b>	<b>*Change No.</b>
Front Cover.....	0		
a – b.....	0		
A – B.....	0		
i – vi.....	0		
WP 0001 00 – 0066 00.....	0		
Index 1-6.....	0		
Authentication Page.....	0		
Electronic 2028 Instructions	0		
Sample DA From 2028.....	0		
Blank Form 2028.....	0		
Back Cover.....	0		

**\*Zero in this column indicates an original page or work package**

**THIS PAGE INTENTIONALLY LEFT BLANK**

## TECHNICAL MANUAL

### UNIT AND DIRECT SUPPORT (DS) MAINTENANCE MANUAL (INCLUDING REPAIR PARTS AND SPECIAL TOOLS LIST) FOR PARACHUTE, CARGO TYPE: 28-FOOT DIAMETER CARGO EXTRACTION PARACHUTE ASSEMBLY

NSN 1670-00-040-8135

#### REPORTING ERRORS AND RECOMMENDING IMPROVEMENTS

##### ARMY

You can help improve this manual. If you find any mistakes or if you know of a way to improve the procedures, please let us know. Mail your letter, DA Form 2028 (Recommended Changes to Publications and Blank Forms), or DA Form 2028-2, located in the back of this manual directly to: Commander, US Army Soldier, Biological and Chemical Command, ATTN: AMSSB-RIM-L(N), Kansas St., Natick, MA 01760. You may also submit your recommended changes by E-mail directly to: <amssbriml@natick.army.mil>. A reply will be furnished directly to you. Instructions for sending electronic 2028 may be found at the back of this manual immediately preceding the hard copy 2028.

##### AIR FORCE

Reports by U.S. Air Force units should be submitted on AFTO Form 22 (Technical Order Publication Improvement Report and Reply) and forwarded to the address prescribed above for the Army. An information copy of the prepared AFTO Form 22 shall be furnished to WP-ALC/TILTA, 420 2<sup>nd</sup> Street, Suite 100, Robins AFB, GA 31098-1640.

##### MARINE CORPS

Marine Corps personnel submit NAVMC 10772 for to commander, ATTN: (Code 850), Marine Corps Logistics Bases, 814 Radford Blvd., Albany, GA 31704-1128.

##### NAVY

Submit NAVSEA Form 4160/1 (REV 2-99) to Commander, NSDSA Code 5E30, NAVSURFCENDIV, 4363 Missile Way, Port Hueneme, CA 93043-4307. A Reply will be sent to you.

**DISTRIBUTION STATEMENT A:** Approved for public release; distribution is unlimited.

\*This manual supercedes TM 10-1670-277-23&P, dated 9 October 1990

# TABLE OF CONTENTS

WP Sequence No.

## WARNING SUMMARY

## HOW TO USE THIS MANUAL

## CHAPTER 1 – INTRODUCTORY INFORMATION WITH THEORY OF OPERATION

General Information .....	0001 00
Equipment Description and Data .....	0002 00

## CHAPTER 2 - OPERATOR MAINTENANCE INSTRUCTIONS

Service Upon Receipt .....	0003 00
Assembling the 28-Foot Diameter, Cargo Extraction Parachute .....	0004 00
Preventive Maintenance Checks and Services (PMCS), Introduction.....	0005 00
Preventive Maintenance Checks and Services (PMCS) .....	0006 00

## CHAPTER 3 – UNIT MAINTENANCE INSTRUCTIONS

Shakeout and Airing .....	0007 00
Cleaning and Drying .....	0008 00
Inspection .....	0009 00
Salt-/Fresh-Water Contamination Test .....	0010 00
Packing Procedures .....	0011 00
Sewing Procedures .....	0012 00
Searing and Waxing .....	0013 00
Marking and Restencilling .....	0014 00
Parachute Canopy .....	0015 00
Attachment Loop (Bridle Loop) .....	0016 00
Vent Lines .....	0017 00
Bridle Centering Line .....	0018 00
Vent Reinforcement Band (Upper Lateral Band) .....	0019 00
Gore Section .....	0020 00
Radial Tape .....	0021 00
Vertical Tape .....	0022 00
Panel Edge Reinforcement .....	0023 00
Skirt Reinforcement (Lower Lateral Band) .....	0024 00
Pocket Band.....	0025 00
Suspension Line Attachment Loop .....	0026 00
Suspension Line .....	0027 00
Connector Link .....	0028 00
Adapter Web .....	0029 00
Adapter Web Body .....	0030 00
Adapter Web Long Buffer .....	0031 00
Adapter Web Short Buffer .....	0032 00
Adapter Web Fixed Keeper .....	0033 00
Deployment Bag .....	0034 00



**TABLE OF CONTENTS - Continued**

**WP Sequence No.**

**CHAPTER 3 – UNIT MAINTENANCE INSTRUCTIONS - continued**

Grommet .....	0035 00
Deployment Bag Retainer Band Keeper .....	0036 00
Deployment Bag Retainer Band Keeper Reinforcement .....	0037 00
Deployment Bag Tie Loop and Tie Loop Reinforcement .....	0038 00
Deployment Bag Pendulum Line .....	0039 00
Log Record Book Pocket .....	0040 00
Deployment Bag Safety Cord .....	0041 00
Deployment Bag Closing Loop .....	0042 00
Deployment Bag Stowage Flap Edge Binding .....	0043 00
Deployment Bag Panels and Flaps .....	0044 00
Deployment Bag Stowage Flap Edge Reinforcement .....	0045 00

**CHAPTER 4 – DIRECT SUPPORT MAINTENANCE INSTRUCTIONS**

Sewing Procedures .....	0046 00
Searing and Waxing .....	0047 00
Marking and Restencilling .....	0048 00
Vent Lines .....	0049 00
Gore Sections .....	0050 00
Radial Tape .....	0051 00
Suspension Line .....	0052 00
Preparation for Storage .....	0053 00
Preparation for Shipment .....	0054 00

**CHAPTER 5 – SUPPORTING INFORMATION**

References .....	0055 00
Maintenance Allocation Chart (MAC) .....	0056 00
Repair Parts and Special Tools List (RPSTL), Introduction .....	0057 00
RPSTL – Group 01, 28-Foot Diameter, Cargo Extraction Parachute .....	0058 00
RPSTL – Group 02, Adapter Web .....	0059 00
RPSTL – Group 03, Deployment Bag .....	0060 00
RPSTL – Group 99, Bulk Materials .....	0061 00
Special Tools List .....	0062 00
National Stock Number Index .....	0063 00
Part Number Index .....	0064 00
Expendable/Durable Supplies and Materials List .....	0065 00
Illustrated List of Manufactured Items .....	0066 00

<b>ALPHABETICAL INDEX .....</b>	<b>INDEX 1</b>
---------------------------------	----------------

**THIS PAGE INTENTIONALLY LEFT BLANK**

## HOW TO USE THIS MANUAL

In this manual, primary chapters appear in upper case/capital letters; work packages are presented in numeric sequence, e.g., 0001 00; paragraphs within a work package are not numbered and are presented in a titles format. For a first level paragraph, title all upper case/capital letters, e.g., FRONT MATTER subordinate paragraph title will have the first letter of the first word of each principle word all upper case/capital letters, e.g., Manual Organization and Page Numbering System. The location of additional material that must be referenced is clearly marked. Illustrations supporting maintenance procedures/text are located underneath, or as close as possible to, their referenced paragraph.

**FRONT MATTER.** Front matter consists of front cover, warning summary, title block, table of contents, and how to use this manual page.

**CHAPTER 1 - INTRODUCTION.** Chapter 1 contains general information and equipment.

**CHAPTER 2 - OPERATOR INSTRUCTIONS.** Chapter 2 contains service upon receipt, initial receipt, receipt of used parachute assembly, and preventive maintenance checks and services information and instructions.

**CHAPTER 3 – UNIT MAINTENANCE INSTRUCTIONS.** Chapter 3 contains maintenance procedures authorized at the unit level.

**CHAPTER 4 – DIRECT SUPPORT MAINTENANCE INSTRUCTIONS.** Chapter 4 provides maintenance procedures authorized at the direct support level.

**CHAPTER 5 - SUPPORTING INFORMATION.** Chapter 5 contains references, expendable and durable items list, maintenance allocation chart, repair parts and special tools list, national stock number index, part number index, and illustrated list of manufactured items.

**REAR MATTER.** Rear matter consists of alphabetical index, DA Form 2028, authentication page, and back cover.

**Manual Organization and Page Numbering System.** The manual is divided into five major chapters that detail the topics mentioned above. Within each chapter are work packages covering a wide range of topics. Each work package is numbered sequentially starting at page 1. The work package has its own page-numbering scheme and is independent of the page numbering used by other work packages. Each page of a work package has a page number of the for XXXX YY-ZZ where XXXX is the work package number (e.g. 0010 is work package 10), YY is the revision number for that work package, and ZZ represents the number of the page within that work package. A page number such as 0010 00-1/(2 blank) means that page 1 contains information but page 2 of that work package has been intentionally left blank.

**Finding Information.** The table of contents permits the reader to find information in the manual quickly. The reader should start here first when looking for a specific topic. The table of contents lists the topics contained within each chapter and the work package sequence number where it can be found.

Example: If the reader were looking for instructions on RADIAL TAPE, which is a unit maintenance topic, the table of contents indicates that unit maintenance information can be found in chapter 3. Scanning down the listings for chapter 3, RADIAL TAPE information can be found in WP 0021 00 (Work Package 21).

An alphabetical index can be found at the back of the manual; specific topics are listed with the corresponding work package number.

**THIS PAGE INTENTIONALLY LEFT BLANK**

**CHAPTER 1**  
**INTRODUCTORY INFORMATION**  
**FOR**  
**PARACHUTE, CARGO TYPE:**  
**28-FOOT DIAMETER, CARGO**  
**EXTRACTION PARACHUTE**

**THIS PAGE INTENTIONALLY LEFT BLANK**

---

**28-FOOT DIAMETER CARGO EXTRACTION PARACHUTE  
GENERAL INFORMATION**

---

**SCOPE**

This manual provides unit and direct support (DS) maintenance instructions for the 28-Foot Diameter, Cargo Extraction Parachute NSN 1670-00-040-8135. This manual also provides a Repair Parts and Special Tools List (RPSTL), located in WP 0057 00 through WP 0061 00.

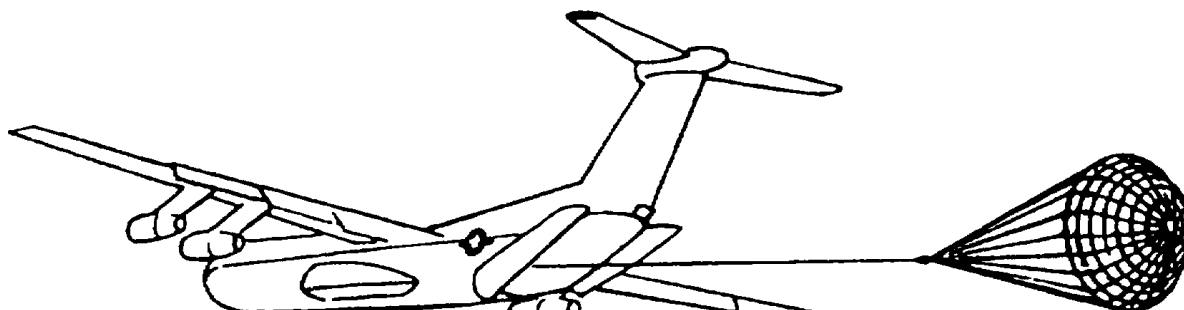

**28-Foot Diameter, Cargo Extraction Parachute, Deployed**

**Equipment Name.** 28-Foot Diameter, Cargo Extraction Parachute.

**Purpose of Equipment.** The parachute provides force to extract an airdrop load from the aircraft.

**MAINTENANCE FORMS, RECORDS, AND REPORTS**

Department of the Army forms and procedures used for equipment maintenance will be those prescribed by DA Pam 738-750 The Army Maintenance Management System (TAMMS), as contained in Maintenance Management Update. Air Force personnel will use AFR 66-1 for maintenance reporting and TO-00-35D54 for unsatisfactory equipment reporting. Navy personnel will report maintenance performed utilizing the Maintenance Data Collection Subsystem (MDCS) IAW OPNAVINST 4790.2, Vol. 3 and unsatisfactory material/conditions (UR submissions) IAW OPNAVINST 4790.2, Vol. 2, chapter 17.

**Reporting of Item and Packaging Discrepancies.** Fill out and forward SF 364 (Report of Discrepancy (ROD)) as prescribed in AR 735-11-2/DLAR 414-.55/SECNAVINST 4355.18/AFR 400-54/MCO 4430.3J.

**Transportation Discrepancy Report (TDR) (SF 361).** Fill out and forward Transportation Discrepancy Report (TDR) (SF 361) as prescribed in Reporting of Transportation Discrepancies in Shipments AR 55-38/NAVUSPINST 4610.33C/AFR 75-18/MCO P4610.19D/DLAR 4500.15.

**REPORTING EQUIPMENT IMPROVEMENT RECOMMENDATIONS (EIR)**

If the design of your 28-Foot Diameter, Cargo Extraction Parachute needs improvement, let us know. Send us an EIR. You, the user, are the only one who can tell us what you don't like about your equipment. Let us know why you don't like the design or performance. Put it on an SF 368 (Product Quality Deficiency Report). Mail it to: Commander, U.S. Army Soldier and Biological Chemical Command, ATTN: AMSSB-RIM-E (N), Kansas Street, Natick, MA 01760-5052. Navy-Submit NAVSEA Form 4160/1 (REV 2-99) to Commander, NSDSA Code 5E30, NAVSURFCENDIV, 4363 Missile Way, Port Hueneme, CA 93043-4307. A reply will be furnished directly to you.

---

**CORROSION PREVENTION AND CONTROL (CPC)**

Corrosion Prevention and Control (CPC) of Army materiel is a continuing concern. It is important that any corrosion problems with this item be reported so that the problem can be corrected and improvements can be made to prevent the problem in future items.

While corrosion is typically associated with rusting of metals, it can also include deterioration of other materials, such as rubber and plastic. Unusual cracking, softening, swelling, or breaking of these materials may be a corrosion problem.

If a corrosion problem is identified, it can be reported using Standard Form SF 368, Product Quality Deficiency Report. Use of keywords such as "corrosion," "rust," "deterioration," or "cracking" will ensure that the information is identified as a CPC problem.

The form should be submitted to the address specified in DA PAM 738-750, Functional Users Manual for the Army Maintenance Management System (TAMMS).

**DESTRUCTION OF ARMY MATERIEL TO PREVENT ENEMY USE****GENERAL INFORMATION:**

**Objective.** Methods of destruction used to inflict damage on air delivery equipment should make it impossible to restore equipment to a usable condition in a combat zone by either repair or cannibalization.

**Authority.** Destruction of air delivery equipment that is in imminent danger of capture by an enemy is a command decision that must be made by a battalion or higher commander, or the equivalent.

**Implementation plan.** All units, which possess air delivery equipment, should have a plan for the implementation of destruction procedures.

**Training.** All personnel who use or perform such functions as rigging, packing, maintenance, or storage of air delivery equipment should receive thorough training on air delivery equipment destruction procedures and methods. The destruction methods demonstrated during training should be simulated. Upon completion of training, all applicable personnel should be thoroughly familiar with air delivery equipment destruction methods and be capable of performing destruction without immediate reference to any publication.

**SPECIFIC METHODS:**

Specific methods of destroying Army materiel to prevent enemy use shall be by mechanical means, fire, or by use of natural surroundings.

**Destruction by Mechanical Means.** Air delivery equipment metal assemblies, parts, and packing aids shall be destroyed using hammers, bolt cutters, files, hacksaws, drills, screwdrivers, crowbars, or other similar devices used to smash, break, bend or cut.

---

**WARNING**

---

Exercise extreme care when using petroleum products to destroy equipment by fire, as these materials are highly flammable. Improper handling may cause injury to personnel.



**Destruction by Fire.** Items that can be destroyed by fire shall be burned. The destruction of equipment by use of fire is an effective method of destroying low-melting-point metal items (e.g., side rails, threaded portions of nuts and bolts, and platform sheeting). However, mechanical destruction should be completed first, whenever possible, before initiating destruction by fire. When items to be destroyed are made of metal, textile materials (or some comparable low combustible material) should be packed under and around the items, then soaked with a flammable petroleum product and ignited. Proper concentration of equipment, which is suitable for burning, will provide a hotter and more destructive fire.

**Destruction By Use of Natural Surroundings.** Small vital parts of assemblies, which are easily accessible, may be disposed of as follows: Disposal or denial of equipment to an enemy may be accomplished through use of natural surroundings. Accessible vital parts may be removed and scattered through dense foliage, buried in dirt or sand, or thrown into a lake, or other body of water. Total submersion of equipment in a body of water will provide water damage as well as concealment. Salt water will inflict extensive damage to air delivery equipment.

#### **PREPARATION FOR STORAGE OR SHIPMENT**

For storage, refer to TM 10-1670-201-23/T.O. 13C-1-41/NAVAIR 13-1-17, and WP 0053 00 of this manual; for shipment, refer to WP 0054 00 of this manual.

#### **WARRANTY INFORMATION**

The 28-Foot Diameter, Cargo Extraction Parachute does not contain warranty provisions.

#### **NOMENCLATURE CROSS-REFERENCE LIST**

<b>Common Name</b>	<b>Official Nomenclature</b>
28-Foot Extraction Parachute	28-Foot Diameter, Cargo Extraction Parachute

#### **LIST OF ACRONYMS AND ABBREVIATIONS**

BOI	Basis of Issue
C/W	Complied With
CAGEC	Commercial and Government Entity Code
cm.	Centimeter
CPC	Corrosion Prevention and Control
DA	Department of the Army
DS	Direct Support
Dtd	Dated
EA	Each
EDS	Electrostatic Sensitive Discharge
EIR	Equipment Improvement Recommendation
F	Fahrenheit
FSC	Federal Supply Classification
FSCM	Federal Supply Code for Manufacturer
Ft.	Feet
IAW	In Accordance With
IN.	Inches
IP	In-Process Inspector

**LIST OF ACRONYMS AND ABBREVIATIONS - Continued**

Lbs	Pounds
LG	Long
Ltrs	Liters
MAC	Maintenance Allocation Chart
MDCS	Maintenance Data Collection Subsystem
MTG	Mounting
MTOE	Modified Table of Organization and Equipment
MWO	Modification Work Order
NF	National Fine (Thread)
NIIN	National Item Identification Number
NMP	National Maintenance Point
No.	Number
NSN	National Stock Number
OD	Olive Drab
OG	Olive Green
Oz.	Ounces
PAM	Pamphlet
PMCS	Preventive Maintenance Checks and Services
PQDR	Product Quality Deficiency Report
Psi	Pounds Per Square Inch
ROD	Report of Discrepancy
RPSTL	Repair Parts and Special Tools List
SF	Standard Form
SMR	Source, Maintenance and Recoverability
TAMMS	The Army Maintenance Management System
TB	Technical Bulletin
TDR	Transportation Discrepancy Report
TMDE	Test Measurement and Diagnostic Equipment
UOC	Usable on Code
WP	Work Package

**SAFETY, CARE AND HANDLING**

The following subparagraphs summarize the safety, care, and handling requirements for the parachute assembly.

**Safety.** Use care in handling packed parachutes as exposed metal parts could cause painful injuries.

**Care and Handling.** Every effort shall be made to protect the parachute from weather elements, dust, dirt, oil, grease, and acid. An unpacked parachute shall be placed in a suitable sized container. When available, an environmentally controlled building will be used to store parachutes. Parachutes shall be stored in a dry, well-ventilated location and protected from pilferage, dampness, fire, dirt, insects, rodents, and direct sunlight.

**COMMON TOOLS AND EQUIPMENT**

For authorized common tools and equipment, refer to the Modified Table of Organization and Equipment (MTOE) applicable to your unit.

**SPECIAL TOOLS, TEST MEASUREMENT AND DIAGNOSTIC EQUIPMENT (TMDE), AND SUPPORT EQUIPMENT**

Special Tools, TMDE and support equipment are not required.

**REPAIR PARTS AND SPECIAL TOOLS LIST (RPSTL)**

Repair parts are listed and illustrated in WP 0057 00 – WP 0061 00 of this manual.

**END OF WORK PACKAGE**

**THIS PAGE INTENTIONALLY LEFT BLANK**

---

**28-FOOT DIAMETER CARGO EXTRACTION PARACHUTE  
EQUIPMENT DESCRIPTION AND DATA**

---

**EQUIPMENT CHARACTERISTICS, CAPABILITIES AND FEATURES**

A summary of the characteristics, capabilities and features of the equipment is contained in the following subparagraphs:

**Characteristics.** Provides the capability to extract airdrop loads from an aircraft.

**Capabilities and Features:**

The canopy is constructed of a ring slot design supported by radial webs and vertical tapes. When used as a single, in clusters of two or three, the 28-foot diameter cargo extraction parachute acts as the main extraction parachute.

**LOCATION AND DESCRIPTION OF MAJOR COMPONENTS**

The following subparagraphs contain locations and descriptions of major components.

**28-Foot Diameter Cargo Extraction Parachute (see illustrations below and on the following page).**

The canopy is a 28-foot diameter flat-circular ring-slot canopy constructed with nine concentric rings of nylon fabric, which are supported with 36 radial webs. There are 36 suspension lines that are attached on one end to the canopy. The opposite end of the suspension lines are connected to eight detachable connector links, which connect to the adapter web.

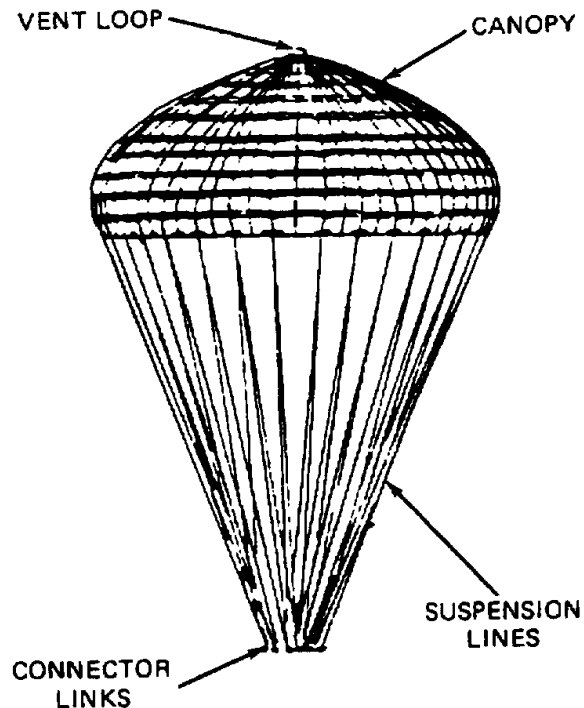

**Side View of The Canopy Assembly**

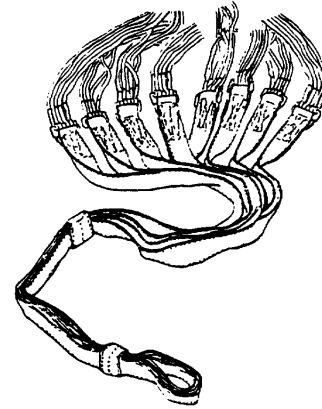
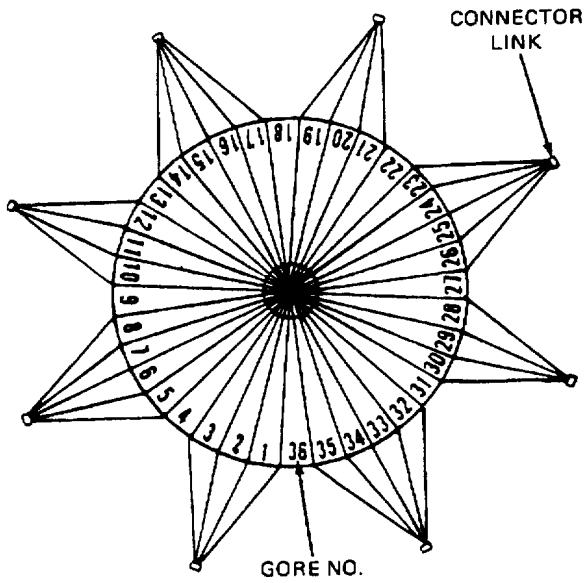

Adapter Web

Suspension Line Arrangement  
Numbering

**Deployment Bag.** The deployment bag is used to deploy the parachute and is constructed with one bridle loop, one V-ring, one bent V-ring, and a suspension line stowage flap. The nylon bag is secured to the canopy with a retaining tie.

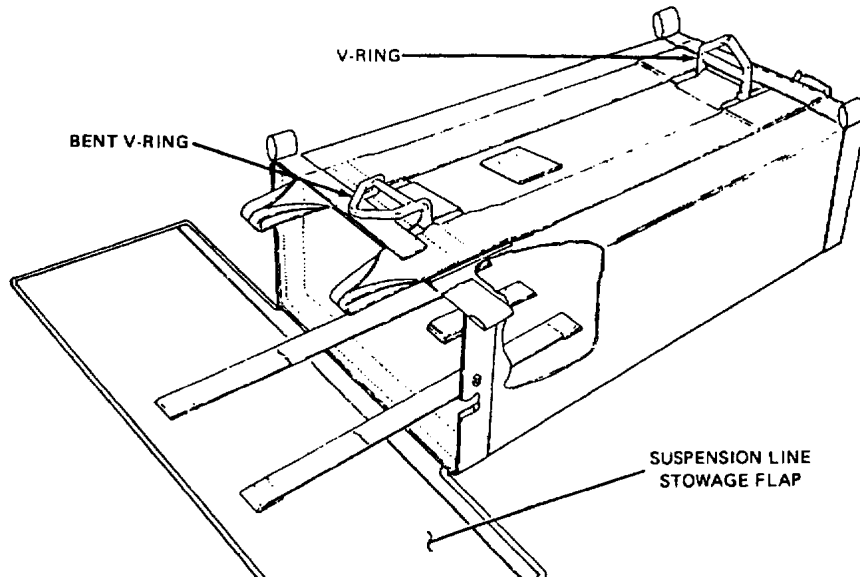

**EQUIPMENT DATA**

The following listing summarizes the specific capabilities and limitations of the equipment and other critical data needed by the unit and direct support (DS) maintenance personnel for maintenance of the 28-foot Cargo Extraction Parachute.

**28-Foot Cargo Extraction Parachute****General:**

Total weight (packed for use)	75-pounds
Dimensions (packed for use)	30-inches long by 18-inches wide by 12-inches high
Cube (packed for use)	3.6 cubic feet

**ASSEMBLY SPECIFICS****Canopy Assembly:**

Shape	Flat-circular
Diameter (nominal)	28-Foot
Design	Ring Slot
Number of Gores	36
Number of Sections Per Gore	9
Gore Material	Type III, 3.25-Ounce Nylon
Number of Vent Lines	18
Number of Suspension Lines	36
Suspension Line Material	$\frac{3}{4}$ -Inch Tubular Nylon, Webbing
Suspension Line Length (from connector link to lower lateral band)	28-Foot
Canopy Length (from lower lateral band to upper lateral band)	13-Foot
Number of Pocket Bands	36
Number of Connector Links	8

**Deployment Bag:**

Pendulum Line Material	Type IV, Coreless Nylon Cord
Pendulum Line Length	85-Inches

**Adapter Web:**

Length	106-Inches
Number of Plys	8

**END OF WORK PACKAGE**



**CHAPTER 2**

**OPERATOR MAINTENANCE INSTRUCTIONS**  
**FOR**  
**PARACHUTE, CARGO TYPE:**  
**28-FOOT DIAMETER, CARGO**  
**EXTRACTION PARACHUTE**

**THIS PAGE INTENTIONALLY LEFT BLANK**

---

## 28-FOOT DIAMETER CARGO EXTRACTION PARACHUTE SERVICE UPON RECEIPT

---

### THIS TASK COVERS:

- Overview
  - Initial Receipt
  - Receipt of Used Parachute
  - After-Use Receipt
- 

### INITIAL SETUP:

#### Materials/Parts

Tape, Lacing and Tying (Item 18, WP 0065 00)

#### Tools

Needle, Tacking (Item 10, WP 0056 00)

#### Personnel Required

92R (10) Parachute Rigger

#### Equipment Condition

All equipment shall be serviceable and ready for use.

---

### OVERVIEW

This chapter contains information necessary to maintain the 28-Foot Diameter Cargo Extraction Parachute on the unit and direct support (DS) maintenance levels in accordance with the Maintenance Allocation Chart (MAC) for the equipment. It includes the following:

1. Procedures for processing a new or used parachute assembly upon receipt.
2. Assembly of components prior to packing.
3. Preventive maintenance procedures to ensure continued serviceability of all components.
4. As required, inspections and maintenance procedures (such as shakeout and airing, cleaning and drying, and salt-water contamination inspections) are performed prior to packing.
5. Detailed packing procedures.
6. Repair methods and repair or replacement procedures for all components of the parachute assembly.

### INITIAL RECEIPT

The following describes the procedures for processing parachutes upon initial receipt.

**General Procedures for Air Delivery Equipment.** When the air delivery equipment is initially procured from a supply source and issued to a using unit, the item(s) will be unpacked from the shipping container(s) and inspected by a qualified parachute rigger (MOS 92R). The inspection performed will be a technical/rigger-type, which will be conducted as outlined in WP 0009 00. Upon completion of the inspection, the item(s) will be tagged as prescribed in the Army Maintenance Management System Aviation (TAMMS) DA PAM 758-751. Serviceable equipment may then be entered either into storage or into use in airdrop operations, as applicable. An unserviceable item will be held and reported in accordance with DA PAM 738-750.

**Inspection Personnel.** Personnel, other than parachute rigger personnel, may assist in the unpacking process of initially received parachutes as directed by the local air delivery equipment maintenance officer. However, the maintenance officer will ensure the entire unpacking effort is conducted under the direct supervision of a qualified parachute rigger (MOS 92R).

**Configuration/Condition.** Acceptance of new equipment from the manufacturer is based upon inspections made of sample lots, which have been randomly selected in accordance with military standards. It is incumbent upon the using activity personnel to bear this in mind whenever equipment is first placed in service. Changes will sometimes evolve from the original equipment design and sometimes contracts are authorized to make deviations in material and construction techniques. Air delivery equipment that has been in the field cannot be expected to meet exacting manufacturing specifications; however, the equipment should closely reflect desired design characteristics. Since repairs, modifications, and/or changes can alter or detract from the configuration originally desired, such equipment shall be air worthy, safe, of the desired configuration, and adequate for intended use.

**Parachute Log Record.** The Army Parachute Log Record, DA Form 3912, is a history-type maintenance document, which accompanies the parachute canopy and pack assemblies through the period of service of the individual assembly. The log record provides a means of recording maintenance actions performed on a parachute canopy assembly. Normally, a log record is initiated and attached to the deployment bag upon receipt by a using unit. However, if the item is subjected to alteration or modification by a maintenance activity during the interim period from date of manufacture to receipt by a using unit, the log record will be prepared by the activity performing the maintenance function. Once initiated, a log record will be attached to and contained in an affixed parachute log record/inspection data pocket until such time as the parachute canopy assembly is destroyed or rendered unfit for further use or repair. Additionally, should an item that requires a log record be transferred from one unit to another, the log record for the parachute assembly will accompany the item in the transfer action. A prepared log record will not be removed or separated from a parachute, and especially a packed parachute, except as directed by the local airdrop equipment maintenance activity officer. A log record which is illegible, lost, damaged, soiled, or precludes further entries due to lack of space will be replaced upon the next repack or inspection, as applicable, with a serviceable item from stock.

**Installing Attaching Tie.** Install attaching tie as follows:

1. Cut a 30-inch length of tape, lacing and tying waxed nylon thread (Item 18, WP 0065 00) and double the lacing length to form a 15-inch length, double strand.
2. Pass looped end of the double lacing length around the centerfold of the log record and form a slip loop on the outside at the log record top.

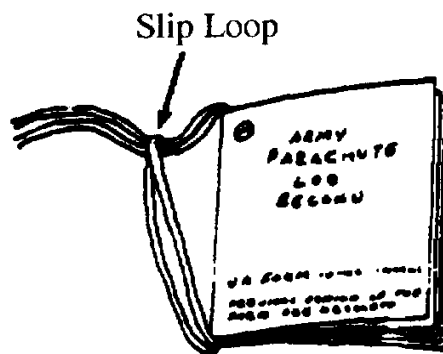

Forming Slip Loop On Log Record Outside

3. Pass lacing length running ends through the corner attaching hole from the front cover of log record book.

Corner Attaching Hole



Passing Lacing Loose Ends Through Corner Attaching Hole

4. Ensure running ends are routed over that part of the lacing length located along the log record centerfold.

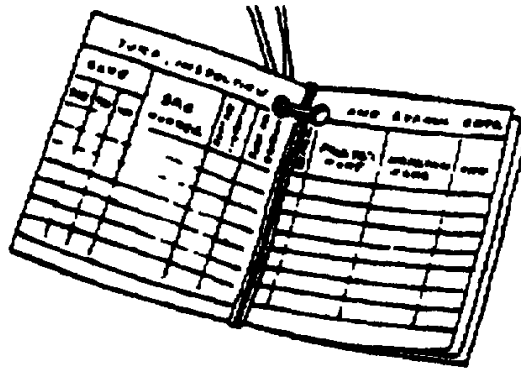

Routing Lacing Loose End Through Log Record Centerfold

5. Complete the attachment tie by making a half hitch on top of the slip loop made in step 2., above.
6. Thread one running end of the log record attachment tie in a tacking needle and pass the tacking needle with attached lacing end, through the edge binding of the applicable parachute log record/inspection data pocket.

- Remove lacing end from tacking needle and make a finished 10-inch long log attaching loop by securing the two lacing ends together with an overhand knot.



Log Record Attachment Tie Completed

- Insert log record into the pocket and secure the record within pocket using the pocket flap and applicable type flap fastener.

**Accomplishing a Log Record.** Upon completion of first technical/rigger-type inspection, the individual performing the inspection will initially prepare a log record for an individual parachute or applicable type parachute harness and accomplish subsequent record entries using the following procedures:

NOTE

Log record book entries will be made with a suitable type blue or black marking device that cannot be erased.

- Inside front cover. Using the information provided on the parachute canopy data block, make the following entries on the inside front cover of the log record. Entries may be continued on the inside of the back cover, if necessary.

SERIAL NO.	○
TYPE	
PART NO.	
DATE OF MFG. (Month & Year)	
MANUFACTURER	
CANOPY CONTRACT NO.	
STATION & UNIT	
<i>(Continued on inside back cover)</i>	

**NOTE**

A parachute canopy serial number is recorded in a log record as a method of establishing control for maintenance, Equipment Improvement Report (EIR) and Product Quality Deficiency Report (PQDR) documentation, and to ensure the correct original record is reattached should the record become detached. A canopy serial number will not be used for property accountability, except in test projects or other special instances.

- a. Serial number. Enter the parachute canopy assembly serial number.
  - b. Type. Enter the parachute type.
  - c. Part number. Enter the part number of the parachute canopy.
  - d. Date of Manufacture. Enter the month and year the parachute canopy was manufactured.
  - e. Manufacturer. Enter the name of the parachute canopy manufacturer.
  - f. Canopy Contract Number. Enter the entire contract number specified for the parachute canopy.
  - g. Station and Unit. Enter the name of the station and unit to which the parachute canopy is currently assigned. When a parachute is transferred permanently to another station and/or unit, original entry will be lined out and the name of the receiving station and/or unit will be entered.
2. Inside Back Cover. Entries may be continued on the inside back cover, if necessary.

The form is a rectangular box with a circular punch hole in the top-left corner. The title "STATION & UNIT (Continued)" is printed in the top-right area. Below the title, there are approximately ten horizontal lines spaced evenly down the page, intended for handwritten entries.

3. Modification Work Order (MWO) Compliance Record Page. When a modification is performed on a parachute canopy, the following entries will be made on the "Modification Work Order Compliance Record" pages of the Log Record.
- a. MWO Number. Enter publication number and date of Modification Work Order (MWO) that describes MWO (Item 1, Illustration on following page).
  - b. MWO Title. Enter a short, abbreviated title extracted from the MWO prescribing the work.

- c. Modified By. Enter the last name of the individual who has performed the modification. If the original log record for the parachute has been lost, and it has been ascertained through inspection that a particular modification has been accomplished, the entry for this column will be C/W, COMPLIED WITH (Item 2, Illustration below), which signifies the applicable MWO has been complied with.

Modification Work Order		Compliance Record					
MWO Number	MWO Title	Modified By (Name)	INSP By	UNIT	Date		
					Day	MO.	YR.
① 10-1670-277-23&P 15 JULY 01	STATIC LINE STOW MODIFICATION	Venkatesh	TJK	SBCOM	24	3	00
② 10-1670-277-23&P 15 JULY 01	STATIC LINE STOW MODIFICATION	C/W	TJK	SBCOM	24	6	01

- 1. Modification Work Order Compliance Completed.
- 2. Modification Completed By Unknown Due To Lost Original Log Record.

- d. Inspected By. The individual who accomplished the inspection required after modification will sign this entry with their last name only.
  - e. Unit. Enter the unit designation responsible for performing the MWO or in the event of a lost Log Record, the unit to which the inspector is assigned.
  - f. Date. Enter the date (day, month, and year) the modification work was completed.
4. Unit and Direct Support Repair and Inspection Data. When a parachute canopy assembly is initially received from a supply source and a technical/rigger-type inspection is performed, the inspection accomplishment will be documented on the "Unit and Intermediate Repair and Inspection Data" page of the individual Parachute Log Record. Additional entries will also be made on this page each time the canopy assembly is repaired or is administered an inspection in compliance with a Maintenance Advisory Message (MAM) or Ground Precautionary Message (GPM). The page completion criteria is as follows:
- a. Type of Repair. Enter the type of repair, completion of initial inspection, repair accomplishment, or MAM or GPM compliance.
  - b. Inspection By. The individual who accomplished the inspection required will sign this entry with last name.
  - c. Unit. Enter the unit designation responsible for performing the type of repair.
  - d. Date. Enter the date (day, month and year) the repair was performed.

Unit & Direct Support	Repair & Inspection Data				
Type of Repair	Insp. By	Unit	Date		
			Day	MO	YR
① Initial Inspection	Venkatesh	SBCOM	12	2	01
② 1 Sec and 4 lines replaced	Gravel	SBCOM	3	3	01
③ TB 10-1670-213-20/5	Burrows	SBCOM	10	4	01

- 1. Completion Of Initial Inspection.
- 2. Repair Accomplishment.
- 3. Technical Bulletin Inspection Compliance.



- 5. Note Page. A page is provided at the back of the parachute log record to accommodate recording of additional data pertinent to the serviceability of a parachute canopy assembly. This shall also include the month and year the item was placed in service.

**NOTES**

RISER MFG DATE: JAN '86  
 PLACED IN SERVICE: MAR '86  
 IMMERSSED IN SALT WATER: 26/10/86  
 RINSED 27/10/86

- 6. Jump, Inspection, and Repack Data Page. Beginning with the initial packing of a parachute and each time a parachute is repacked or administered a routine inspection, make the applicable entries on the JUMP, INSPECTION, AND REPACK DATA page of the log record as follows:

JUMP, INSPECTION,				AND REPACK DATA				
DATE			BAG NUMBER	ROUTINE INSPECTION	REPACK	PACKER'S NAME	INSPECTOR'S NAME	UNIT
DAY	MO.	YR.						
6	1	02	005439		IN	Gravel	Venkua	

- a. Date. Enter the data (day, month, and year) of each inspection and packing action applied to the parachute. These actions include the initial pack, after-use repack, 120-day inspection and repack, and routine inspection.
- b. Bag Number. If the parachute is of troop-type design, enter the deployment bag number that is marked on the bag suspension line protector flap.
- c. Routine Inspection. Enter a checkmark when an emergency-type personnel parachute is administered a routine inspection.
- d. Jumped or Dropped. No entry required.
- e. Repack. For initial packing, enter IN, thereafter enter a checkmark in the column each time the parachute is repacked.

- f. Packer's Name. The packer performing the initial pack, repack, or routine inspection, as applicable will sign this entry.
- g. Inspector's Name. The inspector who has performed the pack-in-process inspection or routine inspection, as applicable, will sign this entry.

**NOTE**

A parachute log record that is completely filled out, lost, illegible, or in an otherwise unserviceable condition, will be replaced with a serviceable log record.

7. Replacing a filled out or unserviceable log record.
  - a. Using a suitable blue or black marking device, enter NEW BOOK on the outside front cover of the replacement log record.
  - b. Transcribe the information from the inside front cover of the original log record to the inside front cover of the replacement log record. If the original data is illegible or missing, use the canopy information data block to collect the required data.
  - c. In the replacement log record; transcribe the initial and last entry made on the JUMP, INSPECTION, AND REPACK DATA page of the original log record.
  - d. Transcribe all data from the remaining pages of the original log record to the appropriate pages of the replacement log record.
  - e. After all original data has been transcribed, destroy the original log record.
8. Replacing a lost log record.

**NOTE**

Any time a log record is discovered missing from a parachute, a placement log record will be initiated during repack or inspection, as applicable.

- a. Using a suitable blue or black marking device, enter NEW BOOK at the top of the inside front cover of the replacement log record.
- b. Accomplish the log record inside front cover as detailed above.
- c. The age life of the canopy will be obtained from the date of manufacture or, if available, the date the canopy was placed into service as indicated on the canopy information data block. Enter the date placed in service (initial) and other applicable data on the JUMP, INSPECTION, AND REPACK DATA page of the log record as detailed above. Enter IN if date placed in service is known. If unknown, enter UNK.

- d. If it can be ascertained by inspection that a previous Modification Work Order (MWO) has been complied with, applicable entries will be made on the appropriate page of the replacement log record.
- e. Attach the replacement log record to the log record/inspection data pocket using the procedures detailed above.

**RECEIPT OF USED PARACHUTE**

Upon initial receipt of used parachute proceed as follows:

1. Follow procedures given in the GENERAL PROCEDURES FOR AIR DELIVERY paragraph above, and check each component for excessive wear and tear.
2. If defects or damages are discovered, process the parachute for maintenance at the maintenance level assigned by the MAC (WPs 0056 00 and 0057 00).

**AFTER-USE RECEIPT**

When a parachute is received at the maintenance activity following its use during airdrop, it must be given a shakeout and aired (WP 0007 00), and, if necessary, cleaned (WP 0008 00) before it can be returned to service. If a parachute is issued but not used, it does not need to be given a shakeout; however, it must be aired if it has been subjected to conditions of dampness.

**CHECKING UNPACKED EQUIPMENT AFTER SHIPMENT**

1. Inspect equipment for damage incurred during shipment. If the equipment has been damaged, report the damage on a SF 361, Transportation Discrepancy Report (TDR).
2. Check the equipment against the packing slip to see if the shipment is complete. Report all discrepancies in accordance with the instructions in DA PAM 738-750.
3. Check to see whether the equipment has been modified.

**END OF WORK PACKAGE**

**THIS PAGE INTENTIONALLY LEFT BLANK**

## 28-FOOT DIAMETER CARGO EXTRACTION PARACHUTE ASSEMBLING THE 28-FOOT DIAMETER CARGO EXTRACTION PARACHUTE

### THIS TASK COVERS:

- Assembly

### INITIAL SETUP:

#### Material/Parts

N/A

#### Personnel Required

92R (10) Parachute Rigger

#### Equipment Condition

Parachute canopy in proper layout on packing table or other suitable surface.

#### Tools

Knife (Item 5, WP 0056 00)

### ASSEMBLY

#### NOTE

When the parachute is received from the supply activity and before it is packed for use, the components must be assembled. This must be accomplished during the layout of the parachute (WP 0011 00, Preparing the Parachute for Proper Layout). If, in assembling components, any component is found to be defective, the parachute must be processed for repair. Place components on a packing table and obtain proper layout of canopy assembly; assemble as follows:

#### Attaching Deployment Bag

1. 28-Foot Diameter Extraction Parachute Packed for Dual Row.
  - a. Cut a suitable length of double ¼-inch cotton webbing for use as a canopy break cord tie.
  - b. Pass the canopy vent loop (bridle loop) through the deployment bag end slot.
  - c. Pass the double length of ¼-inch cotton webbing through the canopy bridle loop and around the deployment bag bridle straps. Secure webbing above the deployment bag bridle straps with a surgeon's knot and a locking knot. Ensure this break cord tie is tight.

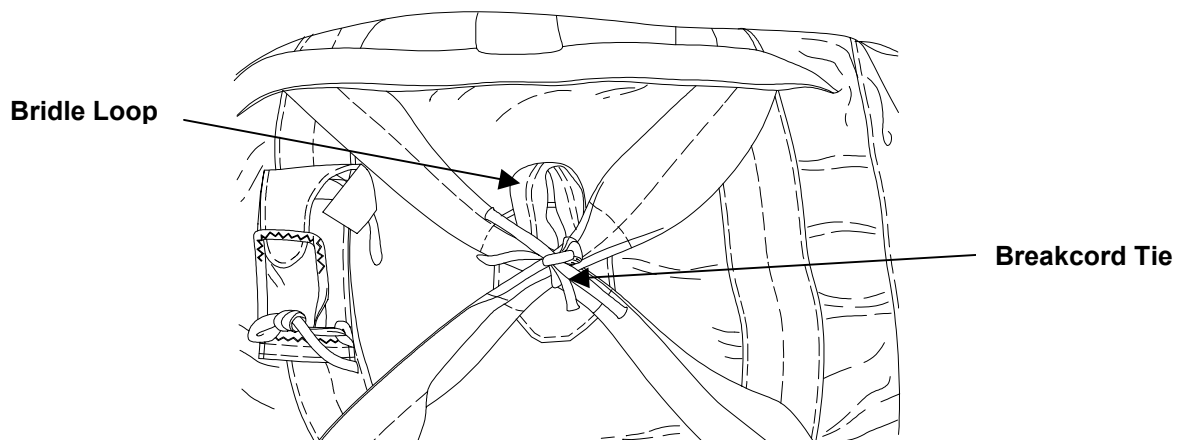

2. 28-Foot Diameter Extraction Parachute Packed for Standard Airdrop.

- a. Cut a suitable length of 1-inch wide tubular nylon webbing for use as a bag retaining line.
- b. Pass one end of the bag retaining line through the canopy vent loop (bridle loop) and center the line length in the loop.
- c. Align the webbing ends and pass the aligned ends into the bag mouth, through the inside of the bag, and out of the bag end slot.

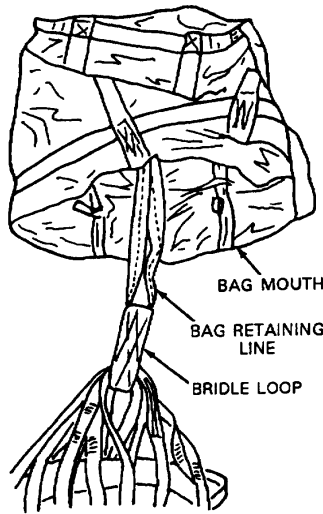

- d. Position the end of the canopy vent loop (bridle loop) at the mouth of the deployment bag.
- e. At the bag top, pass one running end of the retaining line over the top of the deployment bag bridle straps and pass the opposite line running end under the bridle straps.
- f. Secure the webbing ends together above the bag bridle straps with a surgeon's knot and a locking knot. Make an overhand knot in each running end. The bag retaining line finished length shall measure approximately the same as the length of the deployment bag.

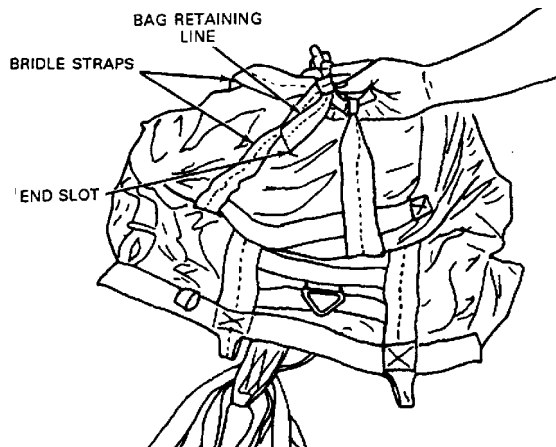

**END OF WORK PACKAGE**

---

**MC1-1C/MC1-1D TROOP BACK PARACHUTE ASSEMBLY  
PREVENTIVE MAINTENANCE CHECKS AND SERVICES (PMCS), INTRODUCTION**

---

**GENERAL**

The following describe PMCS procedures on the unit and direct support levels. The purpose of PMCS is to ensure the 28-Foot Diameter Cargo Extraction parachute is in proper operating condition, and ready for its primary use.

**SCOPE**

The following work packages (WP 0007 00 through WP 0052 00) contain maintenance procedures that are the responsibility of the specified technician, as authorized by the Maintenance Allocation Chart (MAC), and the Source, Maintenance, and Recoverability (SMR) coded items that are identified in the Repair Parts and Special Tools List (RPSTL).

**MAINTENANCE FUNCTIONS/PROCEDURES**

Each of the mentioned work packages above identifies as maintenance function specified in the MAC. All maintenance procedures required to complete a maintenance function are identified under THIS TASK COVERS: in the order in which the work is most logically accomplished.

**PARACHUTE REPACK INTERVAL**

The 28-Foot Diameter Cargo extraction parachute will be repacked at a scheduled interval to ensure airworthiness. When necessitated by climate/storage/use condition, the local airdrop equipment maintenance officer may require more frequent repack intervals. In this regard, a major concern would be rapid fluctuations of temperature (fluctuations around 32 degrees Fahrenheit, freezing point) sustained high or low temperature, or high humidity and heavily polluted atmosphere. The 28-Foot Diameter Cargo Extraction parachute will be repacked at a 365-day interval. However, the repack cycle of the 28-Foot Diameter, Cargo Extraction Parachutes stored in Depots and facilities that maintain contingency stocks of 28-Foot Diameter Extraction Parachute, that are specifically identified as PACKED FOR CONTINGENCY and stored separately from normal parachute stock, will be repacked at a 144-month interval. This is only to occur providing the storage conditions are IAW this TM and TM 10-1670-201-23.

**DROP TESTING CRITERIA**

Drop-testing the 28-Foot Diameter Cargo Extraction parachute consists of physically airdropping an item from an aircraft in flight. The drop-test is used as a means of proving the serviceability of an item or checking parachute rigger proficiency, and will only be performed under the supervision of qualified parachute rigger personnel who satisfy the supervisory requirements outlined in AR 750-32. Drop-testing will usually be conducted by an activity responsible for the inspection and maintenance of airdrop equipment, which includes either parachute packing or airdrop load rigging. The criteria required to accomplish a drop test is as follows:

1. During the drop-test of any type parachute, the deployment of the parachute will be thoroughly monitored and observed to detect any indication of malfunction or defect. Any defect or malfunction detected in a drop test will be annotated in the log record book using procedures outlined in WP 0003 00, SERVICE UPON RECEIPT.
2. Any type of airdrop equipment that indicates evidence of malfunction/defect during, or after, a drop-test will be disposed of as prescribed in WP 0009 00, INSPECTION.
3. Airdrop equipment that does not reflect evidence of malfunction or defect upon completion of a drop-test will be administered a technical/rigger-type inspection as outlined in WP 0009 00, INSPECTION. If serviceable, the item(s) may then remain in use.

**END OF WORK PACKAGE**

**THIS PAGE INTENTIONALLY LEFT BLANK**



---

## 28-FOOT DIAMETER CARGO EXTRACTION PARACHUTE PREVENTIVE MAINTENANCE CHECKS AND SERVICES (PMCS)

---

### GENERAL

The following describe PMCS procedures on the unit and direct support levels. The PMCS table has been provided to ensure the 28-Foot Diameter Cargo Extraction Parachute is in proper operating condition, and ready for its primary mission.

**Warnings and Cautions.** Warnings and cautions appear before applicable procedures. You must observe these WARNINGS and CAUTIONS to prevent serious injury to yourself and others, and to prevent damage to equipment.

**Frequency of Performing PMCS.** PMCS will be performed before equipment is packed for use, during modification and repair, after use, or at any time deemed necessary by the airdrop equipment maintenance officer.

**PMCS Columnar Entries Table 1.** Enter data in columns as follows:

Item number. The item number column shall be used as a source of the item number required for the TM Number column on DA Form 2404 (Equipment Inspection and Maintenance Worksheet) when recording the results of PMCS.

Interval. This column identifies the required PMCS level.

Item to be inspected. Contains the common name of the item to be inspected.

Procedures. Provides a brief description of the procedure by which the checks are to be performed.

**Recording Defects.** All defects discovered during the inspection will be recorded using the applicable specifics in DA PAM 738-750, DA PAM 738-751, and TB 43-0002-43.

**Conservation of Resources.** To conserve time and labor, and to avoid evacuation to an intermediate maintenance activity, unit/detachment commanders may designate, in writing, rigger personnel to accomplish classification inspection of overage air delivery equipment.

**Inspection Function Requirement.** Normally, airdrop equipment maintenance personnel at a packing, rigging, or repair activity will perform a technical/rigger-type inspection. The inspection of initial receipt items will be performed as a separate function from packing or rigging activity; the item to be inspected will be placed in proper layout on packing surface or suitable sized floor area.

Should defect or damage be discovered at any point during the inspection, the inspection will be terminated and the applicable item will be processed and forwarded to repair activity. The repair activity, in turn, will conduct a technical/rigger-type inspection that will be performed by only those parachute rigger personnel cited in AR 750-32. The repair activity inspection of personnel parachutes will be made on a shadow table.

Any defect discovered during a unit level repair activity inspection which exceeds the capability of that activity will require the affected item to be evacuated to an intermediate maintenance function for further determination of economic repair and repair accomplishment, if applicable.

---

### NOTE

---

Parachutes that are deemed unserviceable by a packing or rigging activity will be rigger-rolled in accordance with WP 0054 00, PREPARATION FOR SHIPMENT (Accordion Folding/Rigger Rolling) prior to being sent to a repair activity.

Table 1. Preventive Maintenance Checks and Services (PMCS)

B – Before

D – During

A – After

ITEM NO.	INTERVAL			ITEM TO BE INSPECTED	PROCEDURES
	B	D	A		
00	•		•	The 28-Foot Diameter Cargo Extraction Parachute	Verify that assembly is complete and no components are missing. Check for proper assembly, foreign material, mildew or stains, and log record book.
01	•			Parachute (Packed for Use)	Visually check visible parts for serviceability and completeness without opening pack. Check parachute inspection data record for pack date.
02	•		•	Canopy	<p>As canopy is raised, suspended, and lowered during shakeout, check for dampness, mildew, acid, grease, oil, dirt, foreign material, holes, cuts, tears; broken lines and webbing.</p> <p><i>Fabric Material.</i> Legibility of marking data; completeness; dampness, mildew, dirt, acid, grease, oil, foreign material, rips, burns, cuts, breaks, frays, tears, holes, thin spots, loose weaving; loose or broken stitching, lines, and webbing.</p> <p><i>Hardware Components.</i> Corrosion, rough spots, burrs, breaks, cracks, bends; loose or missing screws.</p>
03	•		•	Deployment Bag	<p>Completeness, dampness, mildew, acid, grease, oil, dirt, foreign material, holes, cuts and breaks.</p> <p><i>Fabric Materials.</i> Completeness; dampness, mildew, dirt, acid, grease, oil, foreign material, rips, burns, cuts, breaks, frays, tears, holes; loose or broken stitching.</p> <p><i>Hardware Components.</i> Corrosion, rough spots, breaks, cracks, bends; loose or missing grommets.</p>
04	•		•	Adapter Web	<p><i>Webbing Length.</i> Dampness, mildew, acid, grease, oil, dirt, foreign material, cuts, burns, frays, missing keeper, loose or broken stitching.</p> <p><i>Attaching Loops.</i> Damaged or missing buffers, loose or broken tacking.</p>

**Table 1. Preventive Maintenance Checks and Services (PMCS) -Continued**

**B – Before**

**D – During**

**A – After**

ITEM NO.	INTERVAL			ITEM TO BE INSPECTED	PROCEDURES
	B	D	A		
05	•	•		Fabric Materials	Completeness, dampness, mildew, dirt, acid, grease, oil, foreign material, rips, burns, cuts, breaks, frays, tears, holes, loose or broken stitching.
06	•	•		Hardware Components	Corrosion, rough spots, breaks, cracks, bends; loose or missing grommets.

**LUBRICATION SERVICE INTERVALS**

The 28-Foot Diameter Cargo Extraction Parachute does not require lubrication service.

**END OF WORK PACKAGE**

**THIS PAGE INTENTIONALLY LEFT BLANK**

**CHAPTER 3**

**UNIT MAINTENANCE INSTRUCTIONS**  
**FOR**  
**PARACHUTE, CARGO TYPE:**  
**28-FOOT DIAMETER, CARGO**  
**EXTRACTION PARACHUTE**

**THIS PAGE INTENTIONALLY LEFT BLANK**

---

**UNIT MAINTENANCE**  
**28-FOOT DIAMETER CARGO EXTRACTION PARACHUTE**  
**SHAKEOUT AND AIRING**

---

**THIS TAKS COVERS:**

- Shakeout
  - Airing
- 

**INITIAL SETUP:**

**Tools**

Brush, Scrub, Household (Item 2, WP 0056 00)

**Personnel Required**

Two, 92R (10) Parachute Rigger

**Equipment Condition**

Parachute suspended.

---

**SHAKEOUT**

A two-person team either indoors within a shakeout room or outdoors at a shakeout tower will accomplish the shakeout. Each parachute will be suspended by the canopy vent and all debris removed by shaking the canopy thoroughly or by brushing with a dry, soft-bristled brush as detailed below:

1. With assistance from no. 2 person, no. 1 person will connect the snap on a pulley rope to the canopy bridle loop.

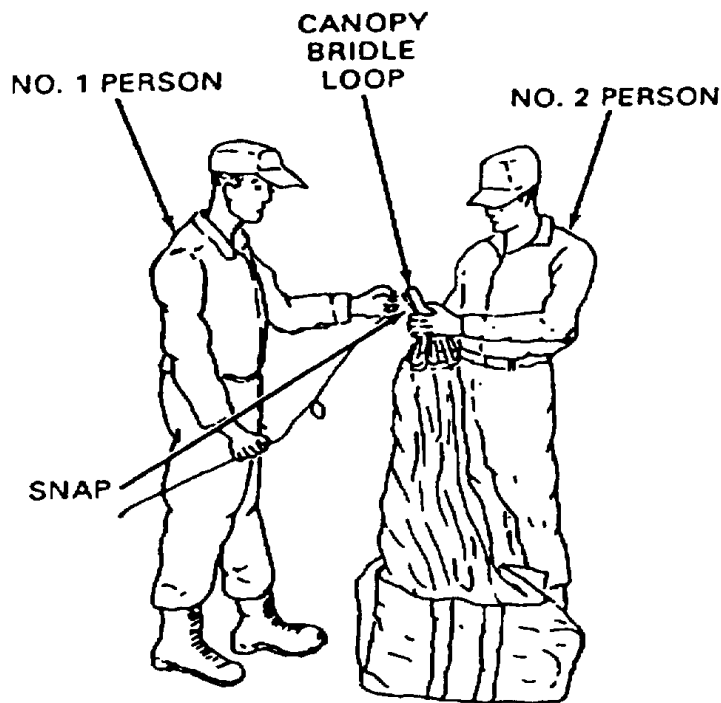

2. Through use of a pulley rope, no. 2 person will raise the canopy to a suitable height, which will enable no. 1 person to perform shakeout on each of the canopy gores. Until gore-shaking process is completed no. 2 person will maintain a steady pull on pulley rope to hold suspended canopy at working height needed by no. 1 person.

- The no. 1 person will grasp any two consecutive suspension lines, one in each hand, and vigorously shake the first gore. When gore is free of debris, no. 1 person passes line from right hand to left hand and grasps next consecutive suspension line in right hand. No. 1 person will shake out each consecutive gore until all suspension lines are held in left hand and all gores are free of debris.

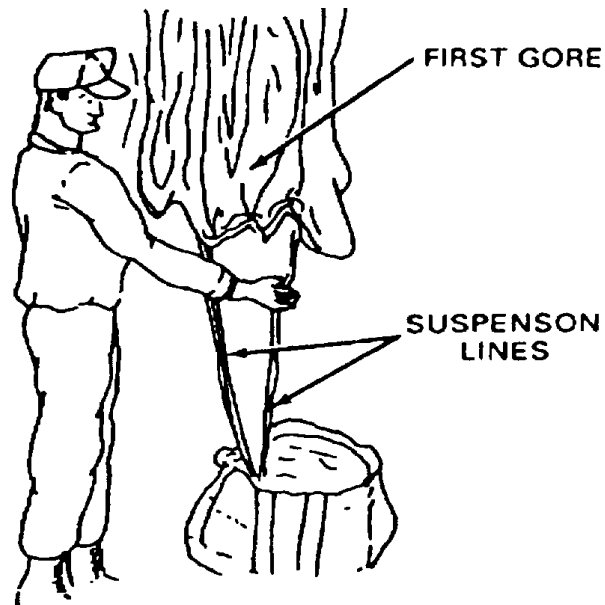

- Once the gore shaking process is completed, no. 2 person will slowly raise suspended canopy higher as no. 1 person clears suspension lines of debris and removes entanglements when possible.

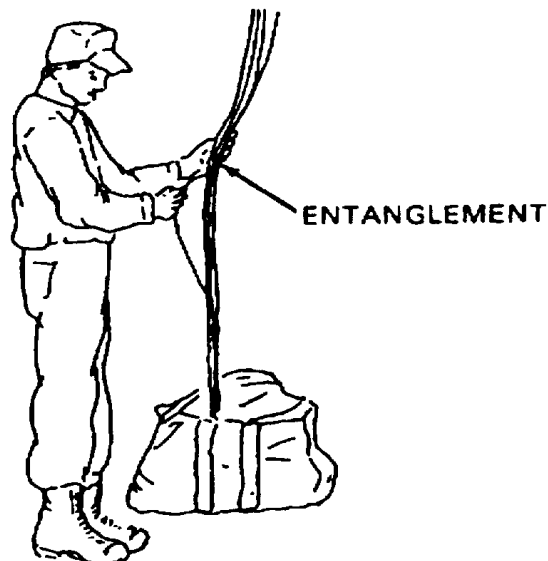

- After suspension lines have been cleared, no. 2 person may hold or temporarily secure pulley rope while no. 1 person proceeds to clear debris from other parachute components such as risers, harness, pack or deployment bag.



- When all components are free of debris, no. 2 person will slowly lower canopy while no. 1 person S-folds suspension lines into a suitable sized container. After suspension lines have been completely folded, no. 1 person will accordion/fold canopy length on top of folded lines.

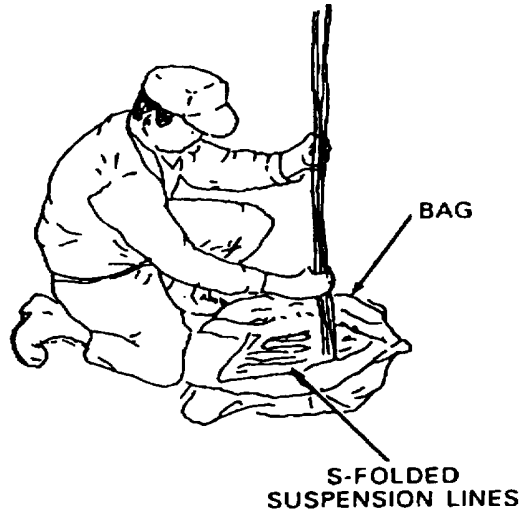

- As canopy folding is being completed, no. 1 person disconnects canopy vent from pulley rope snap. Secure the folded canopy assembly for further handling.

**NOTE**

Do not dry fabric items in direct sunlight or by laying an item on the ground.

**AIRING**

Where dampness and mildew are prevalent, airdrop equipment will be aired at frequent intervals according to the severity of the prevailing conditions. Parachutes that have been previously packed or are unpacked, and have been subjected to conditions of dampness or mildew, will be aired for a period of at least 6 hours prior to being repacked. Airdrop items may be aired either indoors or outdoors in dry weather. However, fabric items will not be aired in direct sunlight. Suspending or elevating the applicable item(s) in a manner that would allow entire exposure to the circulation of air may accomplish airing. Outside facilities used for the shakeout of parachutes may be used for the airing of airdrop equipment if weather conditions permit. If the shakeout facilities are inadequate for airing, the applicable item(s) may be suspended or elevated at several points or by draping over suitable type objects that would not cause damage.

**END OF WORK PACKAGE**

**THIS PAGE INTENTIONALLY LEFT BLANK**

---

**UNIT MAINTENANCE**  
**28-FOOT DIAMETER CARGO EXTRACTION PARACHUTE**  
**CLEANING AND DRYING**

---

**THIS TASKS COVERS:**

- Cleaning Fabric Items With Dishwashing Compound
  - Drying Fabric Items
  - Cleaning Metal Items
  - Rinsing Equipment Immersed in Salt-water
  - Rinsing Equipment Immersed in Fresh-water
- 

**INITIAL SETUP:****Materials/Parts**

Cloth, Abrasive (Item 3, WP 0065 00)  
 Dishwashing Compound (Item 9, WP 0065 00)  
 Lubricant, Solid Film (Item 11, WP 0065 00)  
 Rag, Wiping (Item 15, WP 0065 00)

**Tools**

Brush, Scrub, Household (Item 2, WP 0056 00)  
 File, Flat (Item 4, WP 0056 00)

**Equipment Condition**

Laid out on packing table or other suitable surface.

**Personnel Required**

Two, 92R (10) Parachute Rigger

**References**

WP 0003 00, WP 0009 00, WP 0056 00, & WP 0057 00

---



---

**CAUTION**

---

If, during the cleaning, there exists a possibility that the substance to be removed contains acid or some other equally destructive ingredient, the item will be evacuated to intermediate maintenance activity for determination as to the nature of the substance and item disposition. If the substance cannot be identified or if normal repair procedures will not eliminate all traces of chemical or acid damage, the applicable item will be condemned.

---

**NOTE**

---

Cleaning of parachutes should be held to a minimum and should be performed only when necessary to prevent malfunction or deterioration. When a parachute contains debris, or when it is soiled by dirt, oil, grease, rust, corrosion, or other foreign substances to such an extent that cleaning is necessary, the cleaning should be performed manually and should be limited to the soiled area only, unless the parachute has been contaminated by water. The methods of cleaning must be determined by the nature of the substance to be removed. Do not use cleaning solvent to clean item soiled due to airsickness. Use a solution of hand dishwashing compound and warm water to clean this type of soiling.

**CLEANING FABRIC ITEMS WITH A SOLUTION OF HAND DISHWASHING COMPOUND**

Use dishwashing compound to clean fabric items as follows:

1. Gently brush with a soft bristle brush.
2. Spot clean with a solution of dishwashing compound.

- a. Dissolve one-half cup of dishwashing compound in one-gallon of warm water.
- b. Rub soiled area with a clean cloth dampened with solution of dishwashing compound.
- c. Rinse cleaned area by repeating rubbing process with a clean portion of cloth dampened with fresh, clean water.

**NOTE**

Do not dry fabric items in direct sunlight or by laying an item on the ground.

**DRYING FABRIC ITEMS**

Dry fabric items as follows:

1. Suspend or elevate item in a well-ventilated room or in a heated drying room.
2. Using electric circulating fans may reduce drying time.
3. When heat is used, the heat temperature shall not exceed 160°F (71°C). Preferred temperature is 140°F (60°C).

**CLEANING METAL ITEMS**

Clean metal items as follows:

**CAUTION**

Use care not to damage the adjacent fabric materials.

1. Remove burrs, rough spots, rust or corrosion from metal items by filing with a metal file or by buffing and polishing with abrasive cloth.

**NOTE**

Shield adjacent fabric material before spraying solid film lubricant.

2. Spray metal item with a solid film lubricant and allow to air dry for 24-hours.

---

**NOTE**

---

A small amount of lubricant will not damage fabric, but may cause discoloration and make fabric appear soiled.

**RINSING EQUIPMENT IMMERSSED IN SALT-WATER**

If the parachute, or any of its components, has been immersed in salt-water in excess of 24-hours it will be condemned. Additionally, if the parachute, or any of its components, has been immersed in salt-water for a period less than 24-hours, but cannot be rinsed within 48-hours after recovery, it will also be condemned. However, if the cited time limitations can be met, then immediately upon recovery, suspend or elevate the parachute assembly in a shaded area and allow it to drain for at least 5-minutes. Do not attempt to wring the fabric or the suspension lines. Within 48-hours after recovery, under the supervision of a qualified parachute rigger (92R), rinse the recovered parachute. Items found or known to be contaminated are to be cleaned in the following manner:

1. Place equipment in a large watertight container filled with a suitable amount of fresh, clean water to cover item(s).

---

**CAUTION**

---

Equipment made of cotton fabric immersed in salt-water is to be condemned. Refer to WP 0009 00, INSPECTION, for equipment disposition.

---

**NOTE**

---

If salt water-soaked equipment is too large to be placed in a rinsing container, then the rinsing process will be affected by applying fresh, clean water using a hose on the item.

2. Agitate container contents by hand for 5-minutes.
3. Remove item(s) from container and suspend or elevate equipment in a shaded area, allowing a 5-minute drainage period. Do not attempt to wring equipment fabric or, if applicable, suspension lines.
4. Repeat procedures 1. through 3., above, twice, using fresh, clean water for each rinse.
5. After third rinse, allow equipment to drain thoroughly. Upon completion of draining, dry equipment in accordance with the DRYING FABRIC ITEMS procedures detailed above.
6. When dried, perform a technical/rigger-type inspection of item(s). Corroded metal components, or corrosion-stained fabrics or suspension lines will be either repaired or replaced as prescribed by the MAC, WPs 0056 00 and 0057 00.
7. If recovered equipment is a parachute, record immersion, rinsing, and any repairs in individual parachute log record as detailed in WP 0003 00 (SERVICE UPON RECEIPT).

**RINSING EQUIPMENT IMMERSSED IN FRESH-WATER**

Any airdrop equipment that has been immersed in a fresh-water lake, river or stream will not require rinsing unless it has been ascertained that the water is dirty, oily or otherwise contaminated. Procedures for handling a fresh-water immersed parachute are as follows:

1. Contaminated fresh-water. If the airdrop equipment has been immersed in contaminated fresh-water, rinse, dry and, if applicable, repair the item(s) using the procedures in paragraph f above.
2. Uncontaminated fresh-water. If airdrop equipment has been immersed in uncontaminated fresh-water, item(s) will be cleaned and dried as outlined in this paragraph. Minor discoloration of fabric items resulting from immersion in uncontaminated fresh-water may occur. No attempt should be made to eliminate a minor discoloration, as a slight discoloring is preferable to employing vigorous techniques that may damage fabric.

**END OF WORK PACKAGE**

---

**UNIT MAINTENANCE**  
**28-FOOT DIAMETER CARGO EXTRACTION PARACHUTE**  
**INSPECTION**

---

**THIS TAKS COVERS:**

- Routine
  - Pack-In-Process
  - Technical/Rigger-Type
  - In-Storage
  - Equipment Disposition
- 

**INITIAL SETUP:****Equipment Condition**

Laid out on packing table or other suitable surface.

**Personnel Required**

Two, 92R (10) Parachute Rigger

**References**

DA PAM 738-751; TB 43-002-43;  
DA PAM 738-750; AR 750-1; WP 0003 00;  
WP 0010 00; WPs 005600 and 0057 00

---

**NOTE**

---

For Army personnel, the In-Process Inspector (IP) qualifications will be IAW AR 750-32.

**ROUTINE INSPECTION**

A routine inspection is a visual check performed to ascertain the serviceability of all visible components of a parachute that is packed or rigged for use. The inspection will be made on all components that can be inspected without opening the parachute pack. Prior to use, a parachute rigger will administer this inspection. Parachutes issued for an airdrop operation, and not deployed, will receive a routine inspection prior to being placed into a ready-for-issue storage.

**PACK-IN-PROCESS INSPECTION**

A pack-in-process inspection is performed at specified intervals during the packing of a parachute to ensure that only authorized procedures and methods are being used. A parachute rigger, other than the packer or rigger preparing the applicable equipment for use, will accomplish the inspection. The intervals at which the inspection is performed is as follows:

1. After the parachute is placed in proper layout.
2. After gores are folded and flatfold is completed.
3. After canopy is longfolded.
4. After canopy is stowed.
5. After suspension lines are stowed.
6. After closing the deployment bag.
7. After parachute is completely packed.

**TECHNICAL/RIGGER-TYPE INSPECTION PROCEDURES**

Perform inspection as follows:

1. Overall Inspection. An overall inspection will be made on the 28-foot diameter cargo parachute to ascertain the following:
  - a. Log record/parachute inspection data pocket and form. As applicable, inspect the assembly log record/parachute inspection data pocket to ensure the Army Parachute Log Record (DA Form 3912) is enclosed and properly attached as prescribed in WP 0003 00. Further, remove the log record from the pocket and evaluate the recorded entries to ensure compliance with WP 0003 00.
  - b. Assembly completeness. Ensure that the applicable assembly is complete and no components or parts are missing.
  - c. Operation adequacy. Check item components and parts to ensure proper assembly, which includes attachment and alignment, and that assembled product functions in prescribed manner. Further ensure that no stitch formation or sewn seam has been omitted.
  - d. Markings and stenciling. Inspect each assembly and components for faded, illegible, obliterated, or missing informational data, and identification numbers.
  - e. Foreign materials and stains. Inspect each assembly and related components for presence of dirt or similar type foreign material. Also check for evidence of mildew, moisture, oil, grease, pitch, resin, or contamination by salt-water.
2. Detailed Inspection. In addition to the overall inspection performed in 1., above, a detailed inspection will be performed on materials which constitute assembly or component construction using the following criteria, as applicable:
  - a. Metal. Inspect for rust, corrosion, dents, bends, breaks, burrs, rough spots, sharp edges, wear, deterioration; damaged, loose or missing safety pins.
  - b. Cloth. Inspect for breaks, burns, cuts, frays, holes, rips, snags, tears; loose, missing or broken stitching or tacking; weak spots, wear, or deterioration.
  - c. Fabric tape, webbing, and cordage. Inspect for breaks, burns, cuts, frays, holes, snags, tears, incorrect weaving, and sharp edges formed from searing; loose, missing, or broken stitching, tacking, whipping, and weaving; weak spots, wear, and deterioration.
  - d. Pressure-sensitive (adhesive) tape. Inspect for burns, holes, cuts, tears, weak spots, looseness and deterioration.

**IN-STORAGE INSPECTION**

An in-storage inspection is a physical check conducted on a random sample of airdrop equipment that is located in storage. The purpose of the inspection is to ensure that the equipment is ready for issue, that the item is properly identified and segregated from other types of equipment, that no damage or deterioration of equipment has been incurred, and that all modifications or similar action requirements have been completed. The inspection shall also concern the methods and procedures applied to the storage of airdrop items, the adequacy of storage facilities, efforts of pest and rodent control, and protection against unfavorable climatic conditions. Airdrop equipment that is in storage will be inspected at least semiannually and at more frequent intervals if prescribed by the local parachute maintenance officer. The frequency of inspection may vary according to the type of storage facilities and local climatic conditions. Only parachute rigger personnel designated by the local parachute maintenance officer will conduct in-storage inspections.



**EQUIPMENT DISPOSITION**

Airdrop equipment may be rendered unserviceable by either normal fair wear or by aging and will subsequently be repaired, modified, or condemned, as appropriate. Equipment that is uneconomically repairable (outdated) will be condemned. Disposition of airdrop equipment that is condemned, unserviceable, or for which the serviceability is questionable, will be accomplished using the following procedures, as applicable.

1. Item requiring repair or modification. An airdrop item that requires repair or modification will be tagged in accordance with DA PAM 738-751. Subsequent work on the item will be performed at the maintenance level specified in the MAC, WPs 0056 00 and 0057 00.
2. Disposition of condemned air delivery equipment. Condemned equipment, other than fatality parachutes, will be removed from service and disposed of in accordance with current directives listed in WP 0009 00 of this manual.
3. Rejected equipment. Equipment which, prior to use, is deemed unserviceable for use will be reported in an Equipment Improvement Recommendation (EIR) in accordance with DA PAM 738-751, as authorized by AR 750-1. Each applicable item that is defective will be held and safeguarded pending receipt of disposition instructions from the National Maintenance Point (NMP). In all instances, EIR exhibit material will be handled as prescribed in DA PAM 738-750. If the quality or the serviceability of an item is questionable, clarification and assistance may be obtained by contacting Commander, US Army Soldier and Biological Chemical Command, ATTN: AMSSB-RIM-E(N), Kansas Street, Natick, MA 01760-5052.
4. Equipment of doubtful serviceability. Equipment which has had previous use and has not exceeded normal fair wear or aging criteria, but of which further serviceability is doubtful, will be tagged as prescribed in DA PAM 738-751. In addition, the equipment will be reported in an EIR in accordance with DA Pam 738-750 and AR 750-1. The item (s) in question will be held as EIR exhibit material as outlined in DA PAM 738-750 pending receipt of disposition instructions from the NMP. A maintenance activity holding EIR exhibit material will not tamper with the applicable item(s) or make any attempt to ascertain cause factors. Unnecessary handling or EIR exhibit material may disturb or alter peculiar aspects of the affected item(s) which might affect the judgment of engineering personnel who have the responsibility for final evaluation of EIR actions.
5. Equipment immersed in salt-water. Any airdrop item constructed from cotton material that has been immersed in salt water will be condemned. Cotton thread used for tacking and sewing on nylon parachute packs that have been immersed in salt water will only be replaced when there is visible evidence of deterioration such as extreme discoloration or indications of broken thread. Any airdrop equipment constructed of nylon or rayon material that has been immersed in salt water in excess of 24-hours will be condemned. Additionally, any nylon or rayon airdrop item that has been immersed in salt water for a period less than 24-hours, but which cannot be rinsed within 48-hours after recovery will also be condemned. However, if the cited time limitations can be met, then immediately upon recovery, suspend or elevate the recovered equipment in a shaded area and allow the item(s) to drain for at least 5-minutes. Do not attempt to wring the equipment fabric or the suspension lines. Within 48-hours after recovery, under the supervision of a qualified parachute rigger (92R), rinse the recovered equipment as indicated in WP 0010 00.

**END OF WORK PACKAGE**

**THIS PAGE INTENTIONALLY LEFT BLANK**

---

**UNIT MAINTENANCE**  
**28-FOOT DIAMETER CARGO EXTRACTION PARACHUTE**  
**SALT-/FRESH-WATER CONTAMINATION TEST**

---

**THIS TASKS COVERS:**

- Inspection
- 

**INITIAL SETUP:****Equipment Condition**

Laid out on packing table or other suitable surface.

**Personnel Required**

Two, 92R (10) Parachute Rigger

---

**INSPECTION**

Look for a white crystalline residue. If evidence of salt-/fresh-water contamination is found, refer to the procedures detailed below:

**Rinsing Equipment Immersed in Salt-Water.** If the parachute, or any of its components, has been immersed in salt-water in excess of 24-hours it will be condemned. Additionally, if the parachute, or any of its components, has been immersed in salt-water for a period less than 24-hours, but cannot be rinsed within 48-hours after recover, it will also be condemned. However, if the cited time limitations can be met, then immediately upon recovery, suspend or elevate the parachute assembly in a shaded area and allow it to drain for at least 5-minutes. Do not attempt to wring the fabric or the suspension lines. Within 48-hours after recovery, under the supervision of a qualified parachute rigger (92R), rinse the recovered parachute. Items found or known to be contaminated are to be cleaned in the following manner:

1. Place equipment in a large watertight container filled with a suitable amount of fresh, clean water to cover item(s).

---

**CAUTION**

---

Equipment made of cotton fabric immersed in salt-water is to be condemned. Refer to WP 0009 00, INSPECTION, for equipment disposition.

---

**NOTE**

---

If salt water-soaked equipment is too large to be placed in a rinsing container, then the rinsing process will be affected by applying fresh, clean water using a hose on the item.

2. Agitate container contents by hand for 5-minutes.
3. Remove item(s) from container and suspend or elevate equipment in a shaded area, allowing a 5-minute drainage period. Do not attempt to wring equipment fabric or, if applicable, suspension lines.
4. Repeat procedures 1. through 3., above, twice, using fresh, clean water for each rinse.

5. After third rinse, allow equipment to drain thoroughly. Upon completion of draining, dry equipment in accordance with the DRYING FABRIC ITEMS procedures detailed above.
6. When dried, perform a technical/rigger-type inspection of item(s). Corroded metal components, or corrosion-stained fabrics or suspension lines will be either repaired or replaced as prescribed by the MAC, WPs 0056 00 and WP 0057 00.
7. If recovered equipment is a parachute, record immersion, rinsing, and any repairs in individual parachute log record as detailed in WP 0003 00 (SERVICE UPON RECEIPT).

**Equipment Immersed in Fresh-Water.** Any airdrop equipment that has been immersed in a fresh-water lake, river or stream will not require rinsing unless it has been ascertained that the water is dirty, oily or otherwise contaminated. Procedures for handling a fresh-water immersed parachute are as follows:

1. Contaminated fresh-water. If the airdrop equipment has been immersed in contaminated fresh-water, rinse, dry and, if applicable, repair the item(s) using the procedures in paragraph f above.
2. Uncontaminated fresh-water. If airdrop equipment has been immersed in uncontaminated fresh-water, item(s) will be cleaned and dried as outlined in this paragraph. Minor discoloration of fabric items resulting from immersion in uncontaminated fresh-water may occur. No attempt should be made to eliminate a minor discoloration, as a slight discoloring is preferable to employing vigorous techniques that may damage fabric.

**END OF WORK PACKAGE**

---

**UNIT MAINTENANCE**  
**28-FOOT DIAMETER CARGO EXTRACTION PARACHUTE**  
**PACKING PROCEDURES**

---

**THIS TASK COVERS:**

- Inspection
  - Orientation
  - Preparing Parachute for Proper Layout
  - Removing Inversions
  - Locating Suspension Lines
  - Packing the 28-Foot Cargo Extraction Parachute
  - Packing the 28-Foot Cargo Extraction Parachute for Dual Row Airdrop
- 

**Tools**

Needle, Tacking (Item 10, WP 0056 00)  
 Knife (Item 5, WP 0056 00)  
 Paddle, Packing (Item 11, WP 0056 00)  
 Screwdriver, Cross-Tip (Item 14, WP 0056 00)  
 Separator, Line (Item 16, WP 0056 00)  
 Weights, Packing (Item 25, WP 0056 00)

**Materials/Parts**

Band, Retainer, Rubber (Item 1, WP 0065 00)  
 Cord, Nylon, Type V (Item 8, WP 0065 00)  
 Tape, Pressure Sensitive (Item 21, WP 0065 00)  
 Thread, Cotton, Ticket 8/7 (Item 23, WP 0065 00)  
 Webbing, Cotton, Type I, ¼-IN. (Item 35, WP 0065 00)  
 Webbing, Textile, Nylon, Tubular, ½-IN. (Item 43, WP 0065 00)

**Personnel Required**

Two, 92R (10) Parachute Rigger  
 Two, 92R (20) Parachute Rigger

**Equipment Condition**

Parachute cleaned (WP 0008 00) and given a shakeout (WP 0007 00).

**References**

DA PAM 738-751  
 WP 0003 00, WP 0004 00, WP 0007 00,  
 WP 0008 00, WP 0009 00, WP 0054 00

---



---

**WARNING**

---

Failure to detect areas of damage may result in malfunction of the parachute, or loss of equipment.

**INSPECTION**

If defects or damages are discovered during inspection of a parachute, the parachute must be rigger-rolled and processed for maintenance in accordance with ACCORDION FOLDING/RIGGER ROLLING procedures (WP 0054 00). A technical/rigger type inspection and a pack-in-process inspection must be performed in conjunction with the packing of each parachute (refer to WP 0009 00).

1. **Technical/Rigger Type Inspection.** During the packing of the parachute, it must be given a technical/rigger-type inspection by the packer in accordance with WP 0009 00 detailed above.
2. **Pack-In-Process Inspection.** A designated supervisory rigger, other than the packer, must perform a pack-in process inspection at seven intervals during the packing procedure. The inspection is performed to assure that the parachute is packed according to authorized packing procedures (refer to WP 0009 00).

**ORIENTATION**

Throughout this manual, all directions (right, left, upper, lower, top, bottom, clockwise, and counterclockwise) are given from the rigger's point of view, as the rigger stands at the tension plate end of the packing table facing the apex-hook end of the table.

1. Top. That portion of the equipment that is farthest from the packing surface.
2. Bottom. That portion of the equipment that is nearest to the packing surface.

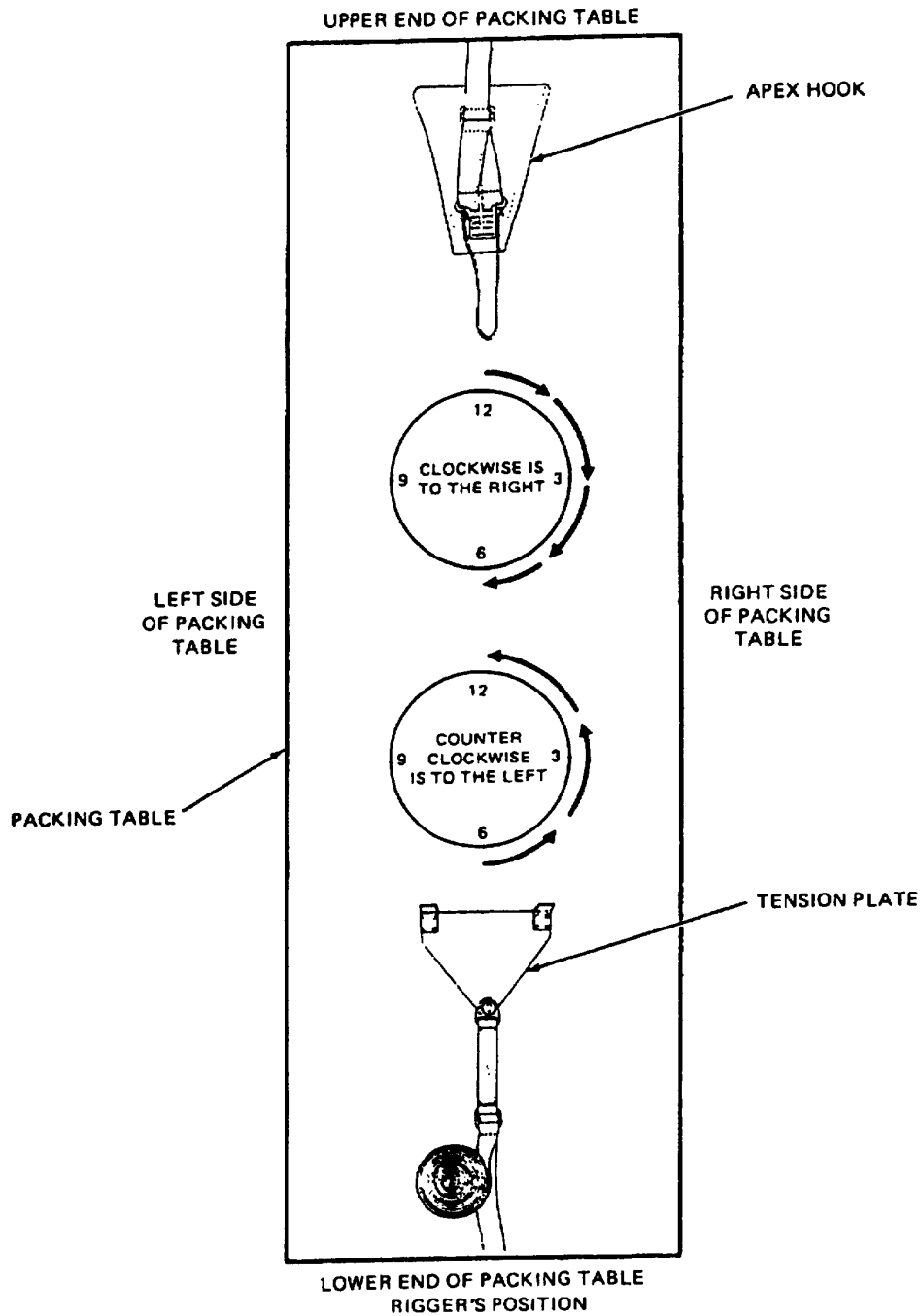

### PREPARING PARACHUTE FOR PROPER LAYOUT

If components of the parachute assembly are detached, assemble the parachute during layout in accordance with WP 0004 00, ASSEMBLY OF THE 28-FOOT DIAMETER CARGO EXTRACTION PARACHUTE.

1. Place packing tools in convenient locations on the packing table.
2. Lay the canopy assembly lengthwise on packing table, and attach the canopy to the packing table apex hook.
3. Attach the adapter web to the tension plate and apply enough tension to keep the canopy on the table. Check vent lines to determine if the canopy is inverted. If the vent lines do not appear attached to the outside of the upper lateral band, the canopy is inverted.

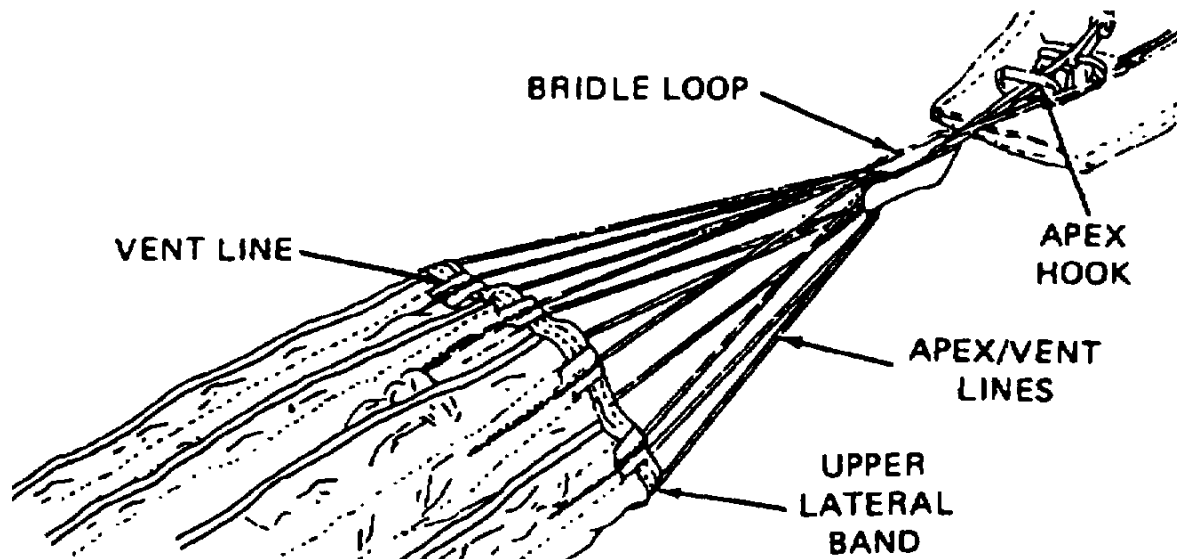

#### NOTE

When inversions, turns, tangles and twists are present in the canopy assembly, the proper sequence for removal to achieve proper layout is to remove an inversion first, remove turns second, then remove tangles and, finally, remove twists.

### REMOVING INVERSIONS

The canopy vent or bridle lines shall be checked to ascertain if the canopy has been inverted. Should the bridle lines be located on the inside of the canopy or if the vent lines are on the inside of the upper lateral band, the canopy is inverted. To remove an inversion, proceed as follows:

1. Remove the canopy from apex hook, pass canopy vent down through the canopy.

2. Bring canopy out the skirt between two adjacent suspension lines.



3. Reattach the canopy to apex hook after the inversion is removed.
4. Removing partial inversion. A partial inversion may occur in an extraction parachute with a ring slot-type canopy. If the vent is on the outside of canopy and pocket bands are on the inside, or vice versa, a partial inversion exists. Remove a partial inversion as follows:
  - a. Disconnect bridle loop from apex hook.
  - b. Trace radial and vertical tapes to annular ring or ring slot, where tapes turn under to canopy and out through annular ring applicable ring slot.

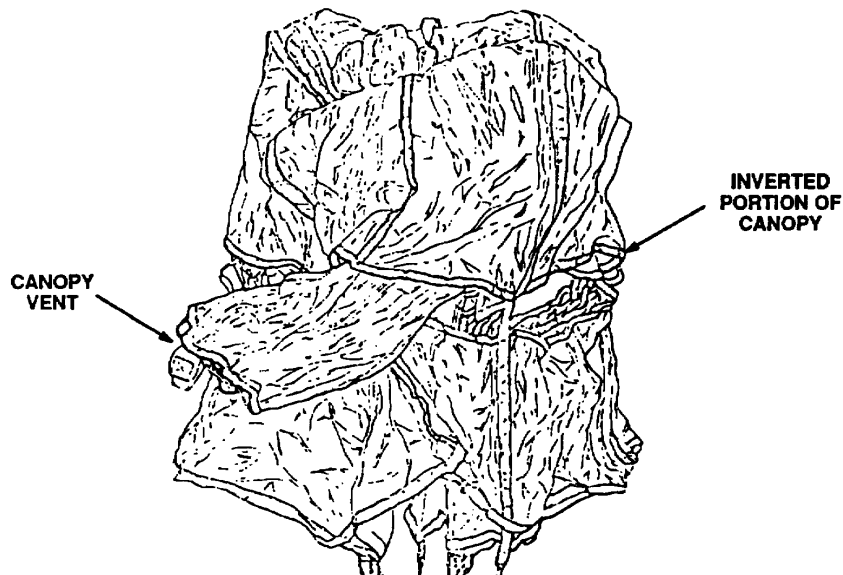



- c. Reattach bridle loop to apex hook.

**NOTE**

Suspension lines 1 thru 36 are divided into two groups, 1 thru 18 in left group and 19 thru 36 in right group.

**LOCATING SUSPENSION LINES**

Divide the suspension lines into left and right groups. Place a packing weight around the right group of lines and move weight toward risers; check for turns, tangles and twists. Remove turns, tangles and twists as follows:

1. Turns. A turn occurs when one group of suspension lines rotates around other group.

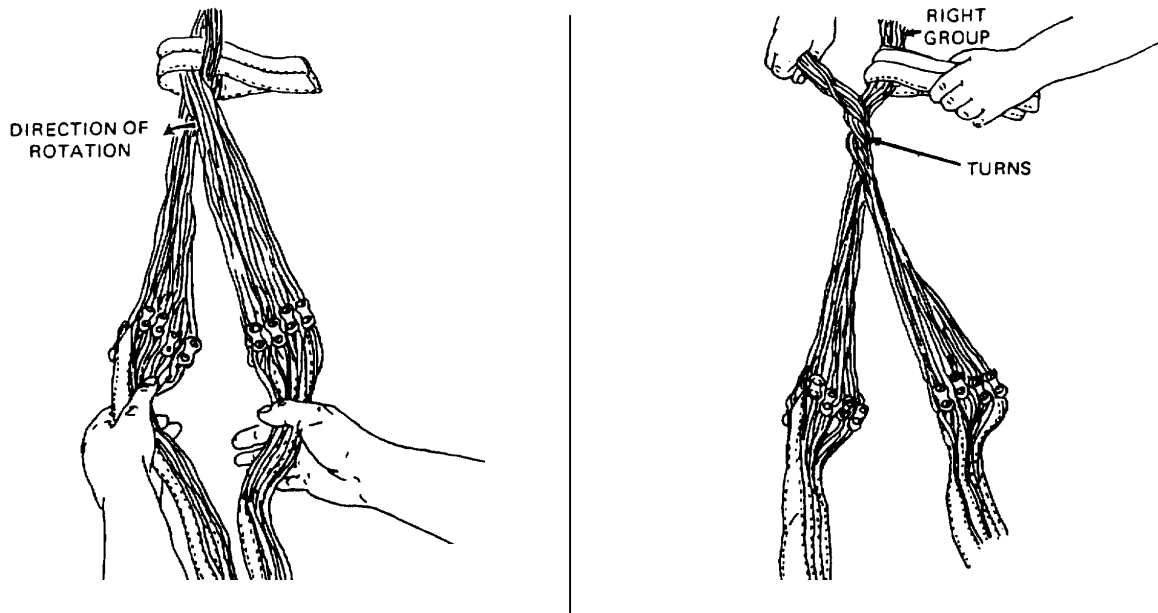

- a. Remove adapter web from tension plate and remove a turn by rotating adapter web in direction opposite to direction of turn.
  - b. Reposition adapter web on tension plate.
2. Tangles. To remove tangle(s), keep the two groups of lines separated and work the tangle(s), as close to the connector link as possible. Detach connector links from the tension plate (refer to illustration on following page).
    - a. Select top line, or lines that form the tangle and, with left hand, lift line, or lines, away from other lines (refer to illustration on following page).

- b. Reach through opening, created by lifting the suspension lines, with right hand, and pull adapter web through opening.

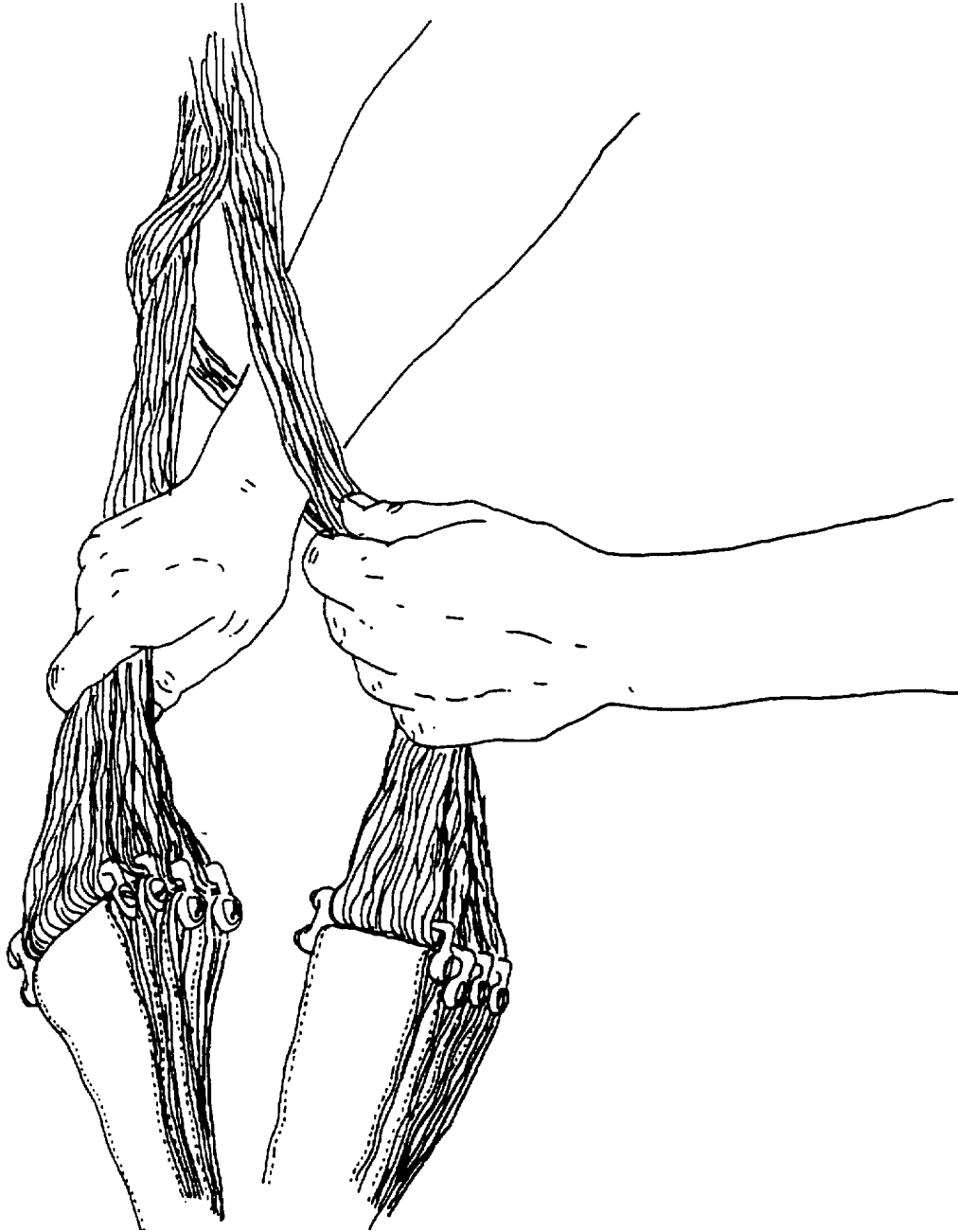

- c. Replace connector links on tension plate.
3. Twists. A twist occurs when the suspension lines within one group becomes improperly crossed.

- a. To remove twists, grasp inside lines at skirt of canopy and trace them to connector lines.

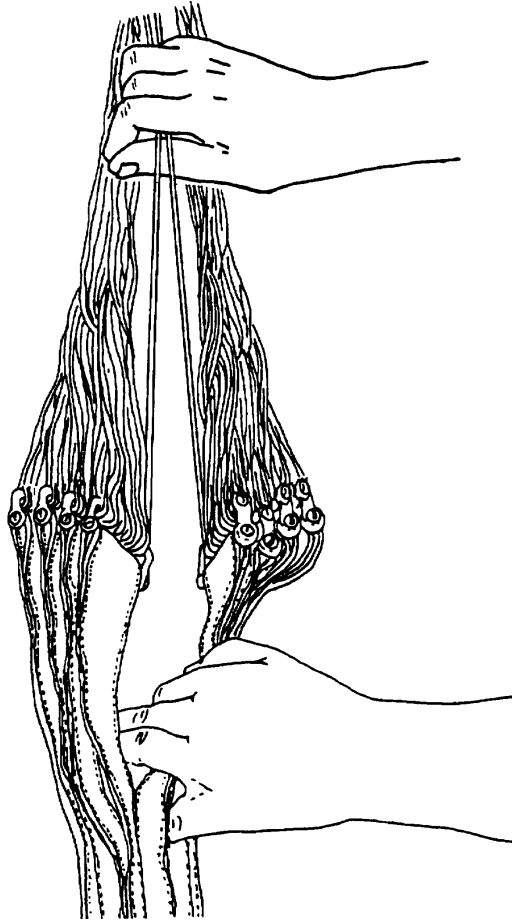

- b. Remove twist by rotating adapter web until lines are in proper location on connector links.
- c. Check suspension lines for proper layout. Lines 1 and 36 will be inside of top connector links. Lines 18 and 19 will be outside bottom of connector links.

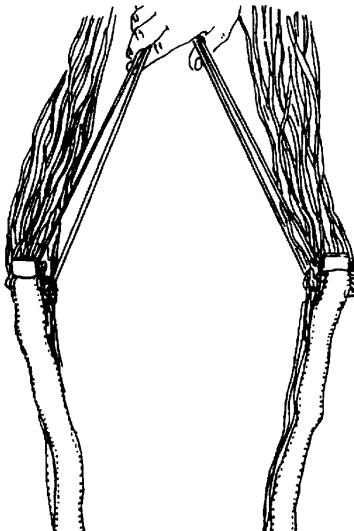

- d. Parachute is now in proper layout.
- e. Attach adapter web to tension plate.
- f. Rigger check number 1.

### PACKING 28-FOOT CARGO EXTRACTION PARACHUTE

After preparing the parachute for proper layout, continue packing the 28-foot cargo extraction parachute as follows:

1. Folding the gores.
  - a. Dress apex, apply tension to canopy.

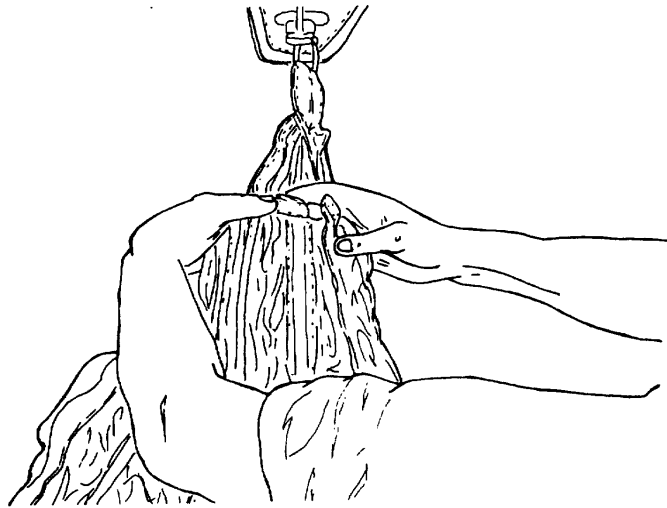

- b. Pick up right group of suspension lines with left hand. Using right hand to hold top center gore in position, flip right group of gores over left group of gores.

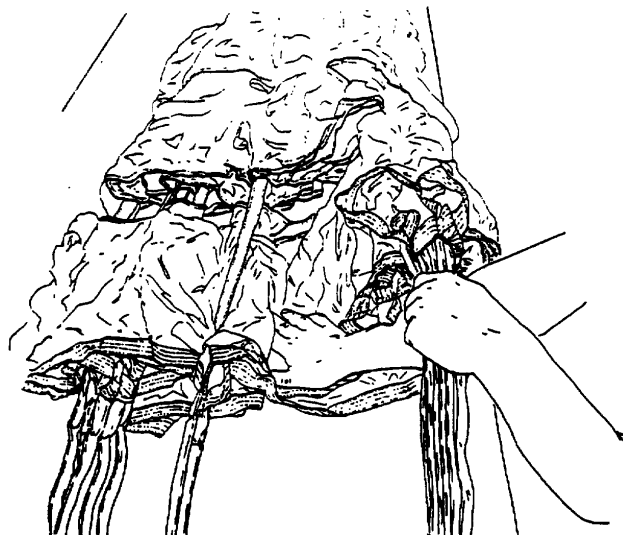

- c. Using right hand, pick up line 19 at canopy skirt and place line between thumb and forefinger of right hand. Move line to right edge of table, and fold right group of gores.
- d. Using left hand, pick up line 20, raise to sufficiently expose gore.

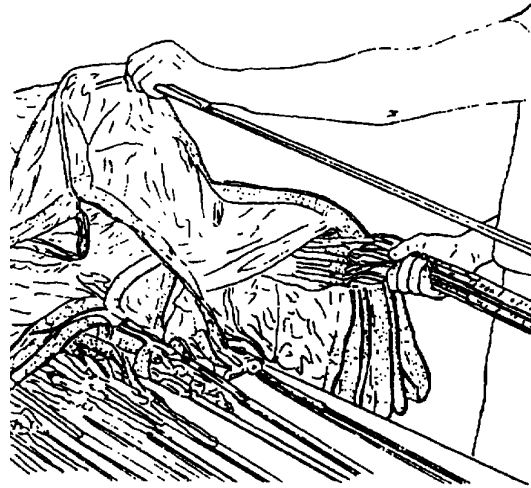

- e. Lower line 20 directly onto line 19, use thumb and forefinger of right hand to hold in place. Gore 19 is folded to the right side of the table.
- f. Repeat step (e.) for gores 21 through 36.
- g. Using the right hand, scissor right group of suspension lines between middle and forefingers. Rotate right hand one-quarter turn clockwise.

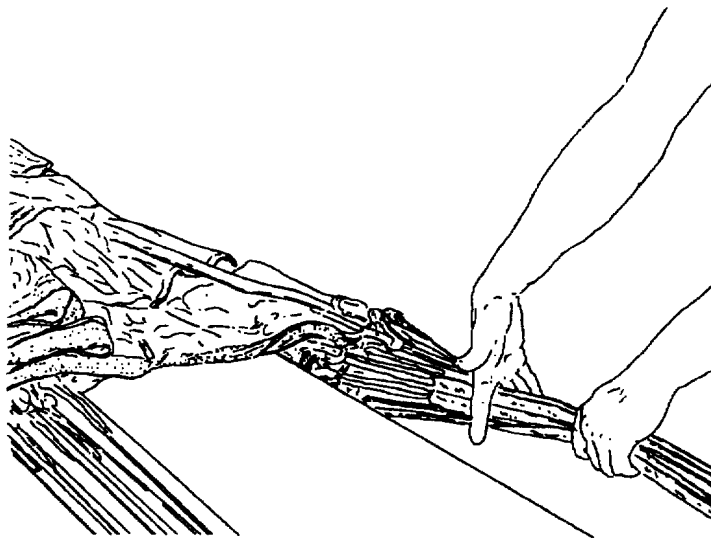

- h. Beginning with line 1, fold left group of gores, do not fold last two gores in this group.

- i. Using left hand, pick up line 1 and raise enough to expose top center gore.
- j. Fold top center gore over right group of gores and place line 1 between thumb and forefinger of right hand. Repeat for lines 2 through 17.
- k. Using left hand, grasp gore 17 five inches to the right of line 18. Insert left elbow under gore 18.

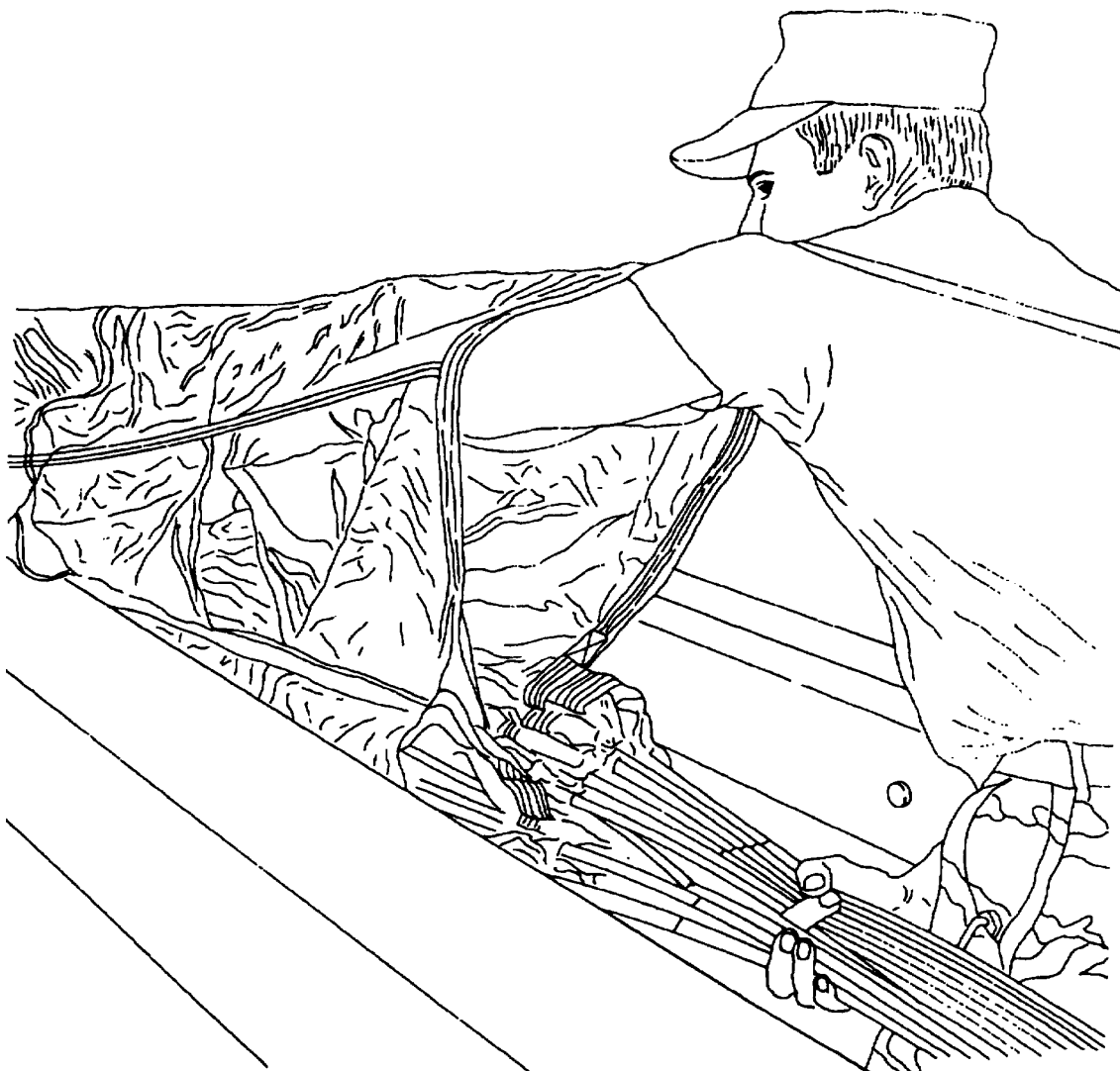

- l. Lower line 18 to right hand, drape gore 17 to right and gore 18 to left.
- m. Place line 18 between thumb and forefinger of right hand.
- n. Place two suspension line groups into a line separator at a point just below canopy skirt.

- o. Using left hand, hold line separator and separate lines. Grasp radial tape with right hand and pull canopy off right side of pack table, allowing all folded gores to drape downward to side of table.

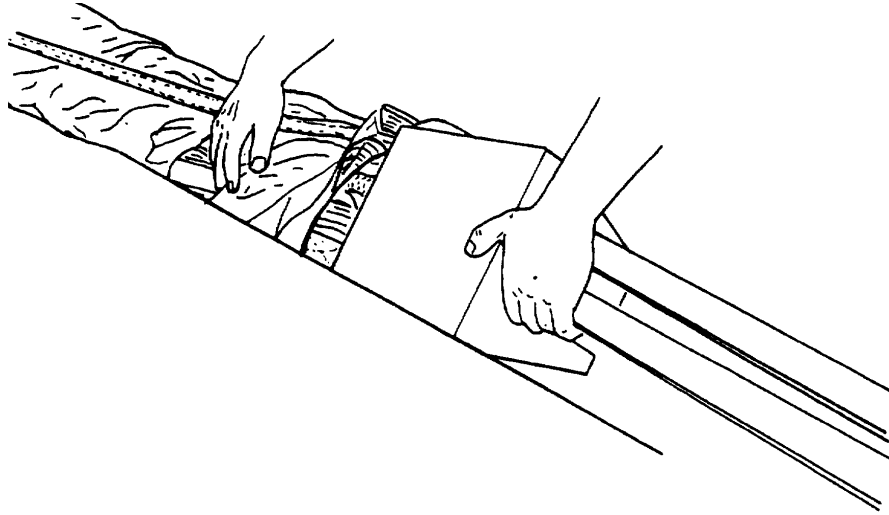

- p. Slide canopy back onto table and rotate suspension lines and line separator one-half turn counterclockwise, which will allow the line separator base to rest on the table. Lay a packing weight across the suspension lines just below the line separator.
- q. Flip left group of gores to left side of table top and apply additional tension.
- r. Using right hand, grasp the top 17 gores of both groups.
- s. Dress the bottom gores of both groups.
- t. Work from vent reinforcement to skirt reinforcement to remove wrinkles from top gores, brush fingertips from radial seam toward folded edges.
- u. To complete the canopy flatfold, dress the gores and the skirt reinforcement (lower lateral band). Ensure that 18 gores are in each gore group and that a clear air channel exists between the two gore groups.

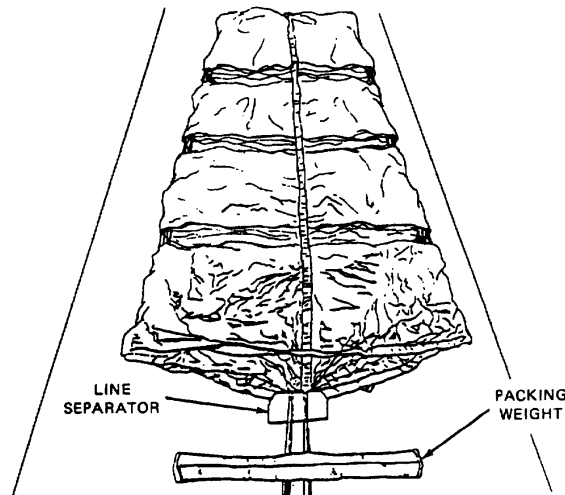

- v. Rigger check number 2.
- 2. Long fold.
  - a. Beginning with panel/section number 1, fold first six sections of right group of gores over radial seam 36 and fold left group over the right group.
  - b. Place packing weights on folded panel/sections to hold the folds in position. Ensure longfold does not exceed width of deployment bag.

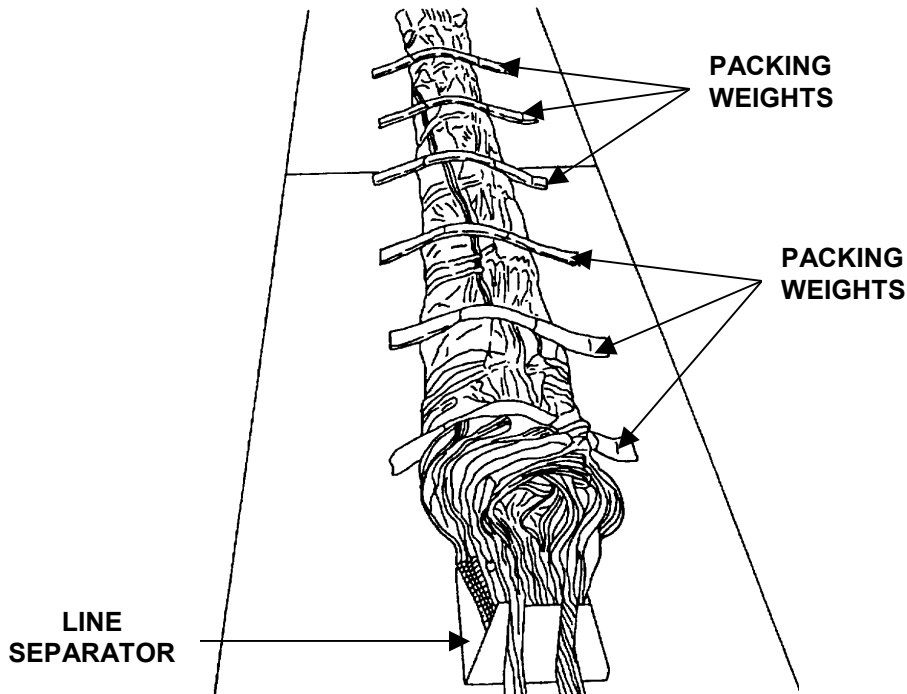

- c. Rigger check number 3.
- 3. Attaching deployment bag retaining line. Attach and stow deployment bag retaining tie following the procedures in WP 0004 00, ASSEMBLY OF THE 28-FOOT CARGO EXTRACTION PARACHUTE.
- 4. Stowing the canopy.

**NOTE**

An assistant packer will be required to ensure proper stowing of canopy.

- a. Wrap each suspension line connector link with two-inch wide, pressure sensitive adhesive cloth tape. Start at a point one inch above the connector link and end one-inch below the connector link. Wrap the tape twice around the entire length.
- b. Before stowing the canopy, install rubber retainer bands at equal intervals along the suspension line stowage flap stow loops. Release canopy from apex hook.



**NOTE**

If parachutes are PACKED FOR CONTINGENCY, in lieu of the rubber retainer bands, one turn single, thread, cotton, ticket 8/7 will be used to secure the suspension lines to the lines to the stowage flap stow loops.

- c. Beginning at upper right inside corner of deployment bag, stow canopy in the bag with S-fold.

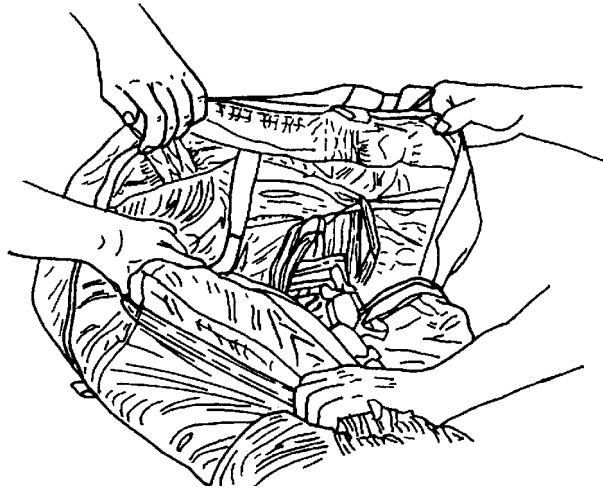

- d. Upon completion of canopy stowage, suspension lines should extend from left side of the bag open end.
- e. Fold suspension lines from left to right across skirt of canopy.
- f. Using one turn double ticket 8/7 cotton thread, secure top and bottom center bag, tie loops together by passing one thread end through bottom center tie loop from right to left, under suspension line fold, through the top center, tie loop from left to right and join thread ends on top of the suspension line fold with a surgeon's knot and a locking knot. Trim tie ends to 2-inches.

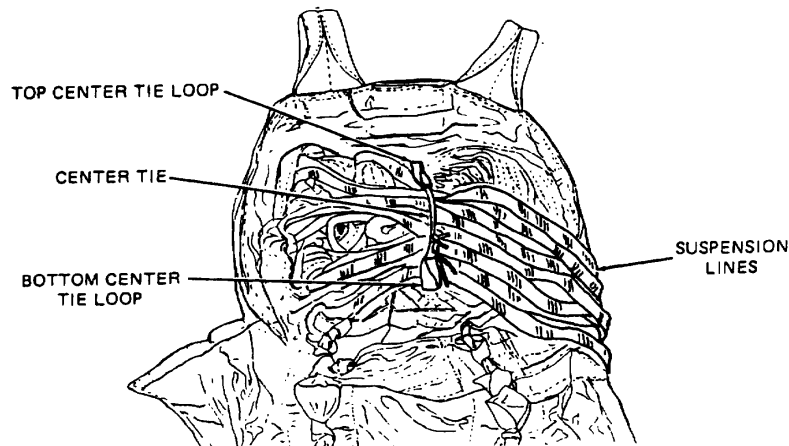

- g. Rigger check number 4.
- 5. Stowing the suspension lines.

**NOTE**

When making suspension line stows, ensure stows do not exceed the width of the deployment bag. All suspension line stows on the 28-foot-diameter cargo extraction parachute will be secured with rubber retaining bands.

- a. To the right of secured center bag tie loops, form a loop in suspension lines and make first suspension line stow at upper right corner of deployment bag suspension line stowage flap. Secure stow with the previously installed retainer band.

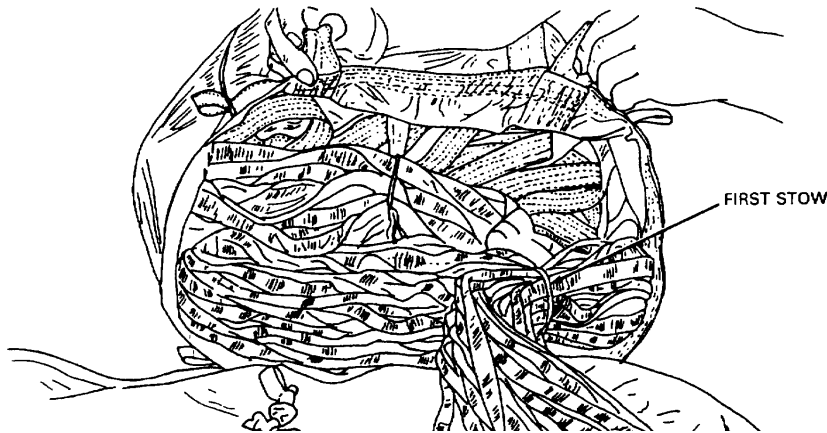

- b. Extend suspension lines to upper left corner of stowage flap, form a loop in the suspension line and secure stow with previously installed retainer band.
- c. Using procedures in (a) and (b) above, continue stowing suspension lines on stowage flap to a point within ten-inches of suspension line connector link assemblies. Make last stow at the lower right side of the stowage flap.

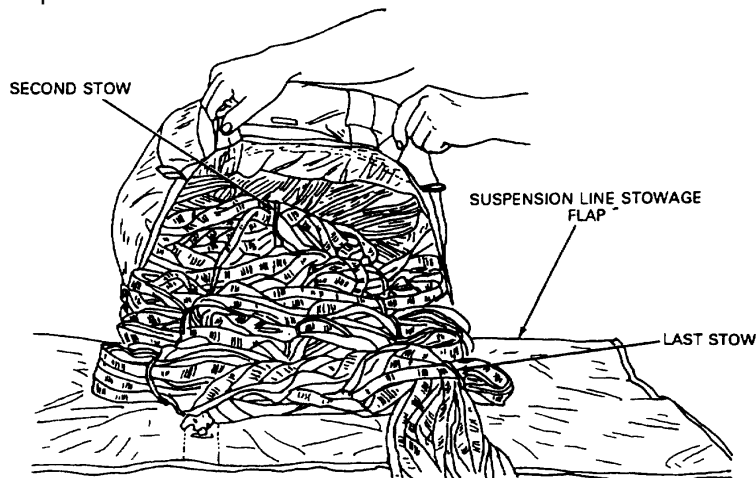

- d. Rigger check number 5.
6. Closing the deployment bag.
    - a. Position suspension line connector link assemblies on inside center top of deployment bag. Extend adapter web from left side.
    - b. S-fold four feet of adapter web on top of the connector links.

**CAUTION**

Ensure that only four and a half feet of the adapter web extends from the deployment bag to prevent the attaching link assembly from striking the floor of the aircraft during extraction parachute deployment.

- c. Be sure adapter web extends four and a half feet from left side of deployment bag.



- d. Fold right side of suspension line stowage flap over stowed suspension lines, fold left flap over right flap.



- e. Beginning at lower end of suspension line stowage flap, tightly roll flap into open end of deployment bag. Ensure four and a half feet of adapter web extends from left side of deployment bag.

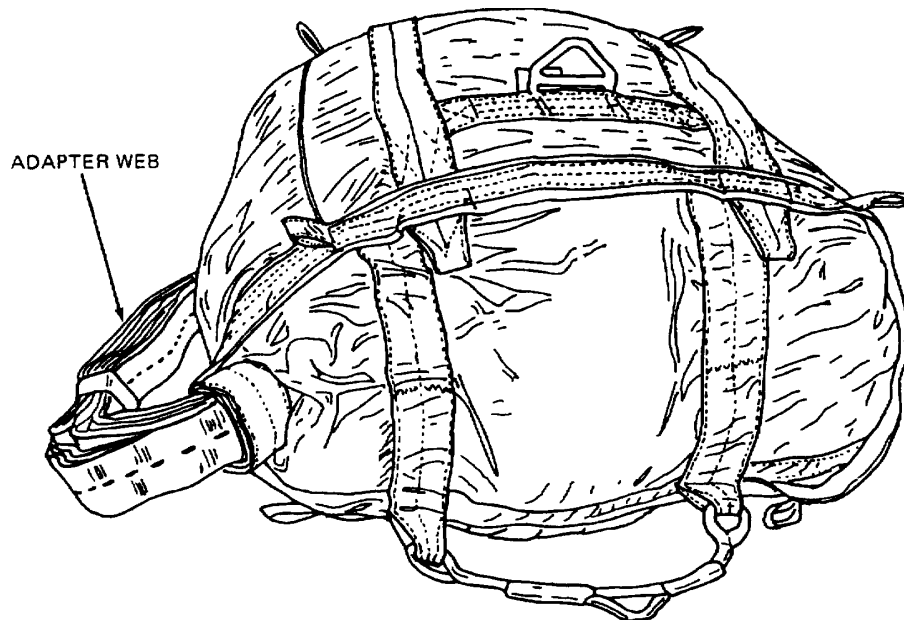

- f. Fold extended adapter web from left to right across rolled suspension line stowage flap.
- g. Using a length of ¼-inch cotton webbing, make left bag closing tie by passing one end of webbing through left bottom bag closing loop from right to left, up behind adapter web, through top bag closing loop from left to right, secure ends together over adapter web, with a surgeon's knot and a locking knot. Trim tie ends to 2-inches.
- h. Using a length of ¼-inch cotton webbing, make right bag closing tie by passing one end of webbing through right bottom bag closing loop from left to right, up behind adapter web, up through right side bag grommet, through right bag closing loop from right to left, secure ends together over adapter web, with a surgeon's knot and a locking knot. Trim tie-ends to two-inches.

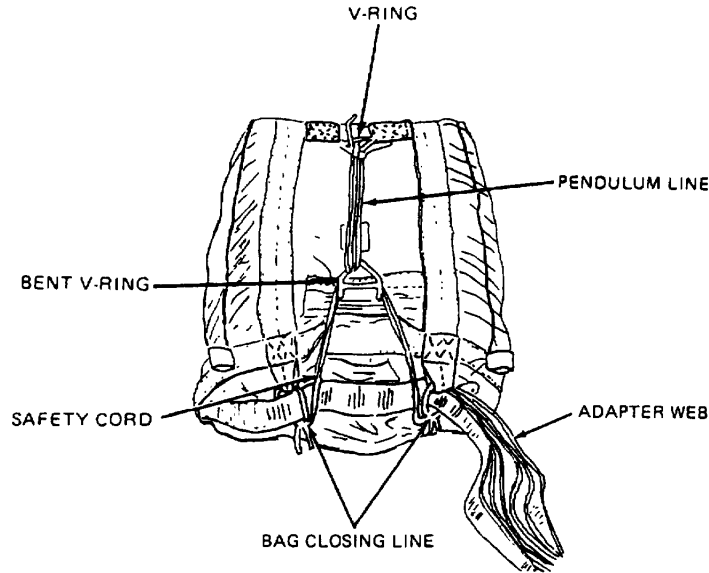

- i. Rigger check number 6.
- j. Pull deployment bag safety cord up over bent V-ring.
- k. Secure safety cord by passing the pendulum line running end through the V of V-ring, draw the pendulum line tight, make additional loops between V-rings as required and secure pendulum line with a half-hitch.

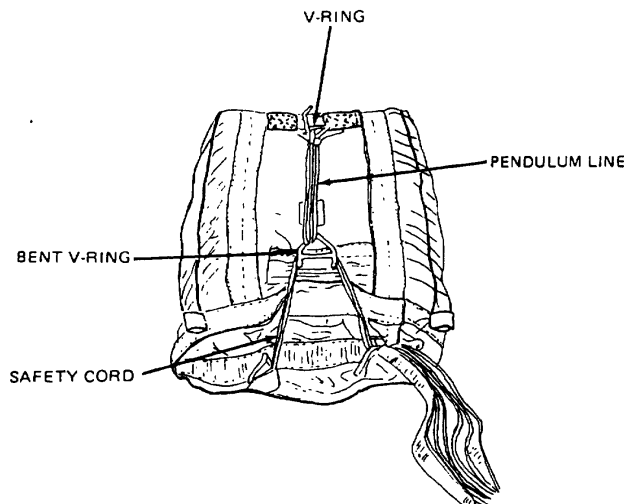

- I. Flip deployment bag over to secure adapter web to deployment bag clustering loops with ¼-inch cotton webbing.

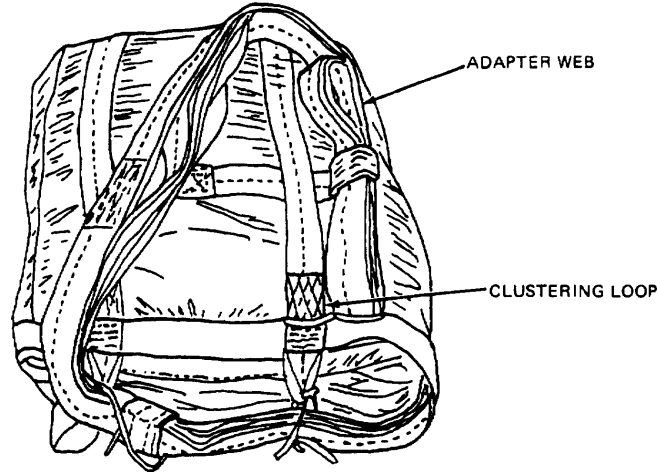

7. Signing DA Form 3912.

- a. Remove parachute log record book from parachute inspection data pocket (log record pocket) on upper end of the deployment and log record pack data as prescribed in WP 0003 00, SERVICE UPON RECEIPT.
- b. After completion of entries, return log record book to inspection data pocket.
- c. Rigger check number 7.

**PACKING 28-FOOT CARGO EXTRACTION PARACHUTE FOR DUAL ROW AIRDROP**

After preparing the parachute for proper layout, continue packing the 28-foot cargo extraction parachute for dual row airdrop as follows:

1. Folding the gores.
  - a. Dress apex; apply tension to canopy.

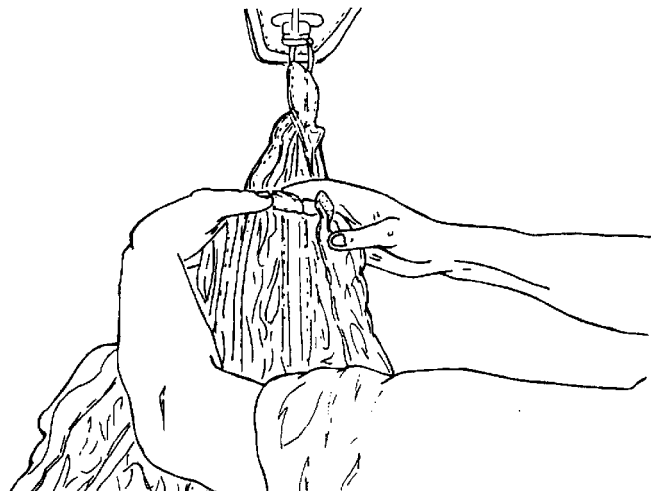

- b. Pick up right group of suspension lines with left hand. Using right hand to hold top center gore in position, flip right group of gores over left group of gores.

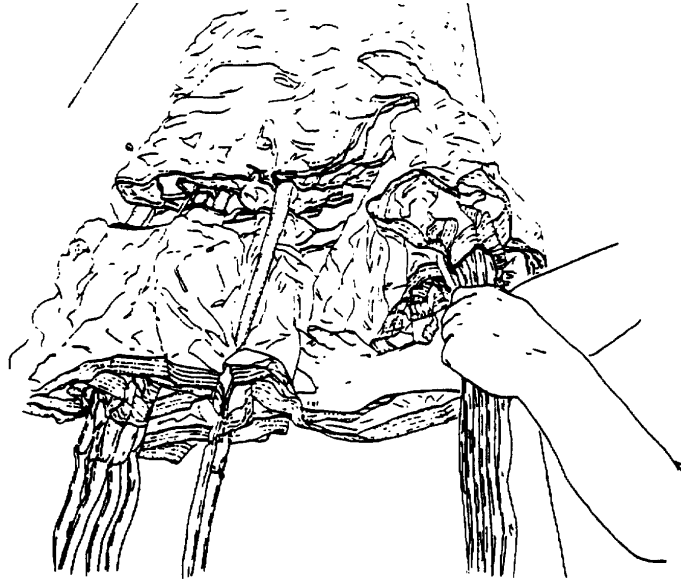

- c. Using right hand, pick up line 19 at canopy skirt and place line between thumb and forefinger of right hand. Move line to right edge of table, and fold right group of gores.
- d. Using left hand, pick up line 20, raise to sufficiently expose gore.

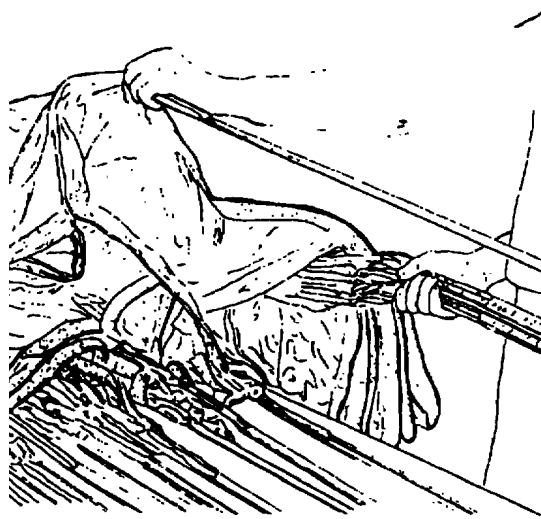

- e. Lower line 20 directly onto line 19, use thumb and forefinger of right hand to hold in place. Gore 19 is folded to the right side of the table.
- f. Repeat step (e.) for gores 21 through 36.

- g. Using the left hand, scissor right group of suspension lines between middle and forefingers. Rotate right hand one-quarter turn clockwise.

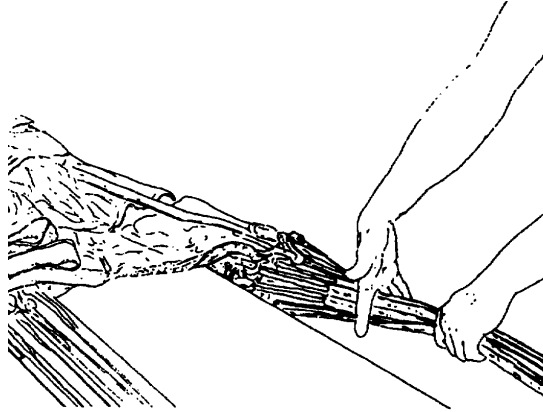

- h. Beginning with line 1, fold left group of gores, do not fold last two gores in this group.
- i. Using left hand, pick up line 1 and raise enough to expose top center gore.
- j. Fold top center gore over right group of gores and place line 1 between thumb and forefinger of right hand. Repeat for lines 2 through 17.
- k. Using left hand, grasp gore 17, five-inches to the right of line 18. Insert left elbow under gore 18.

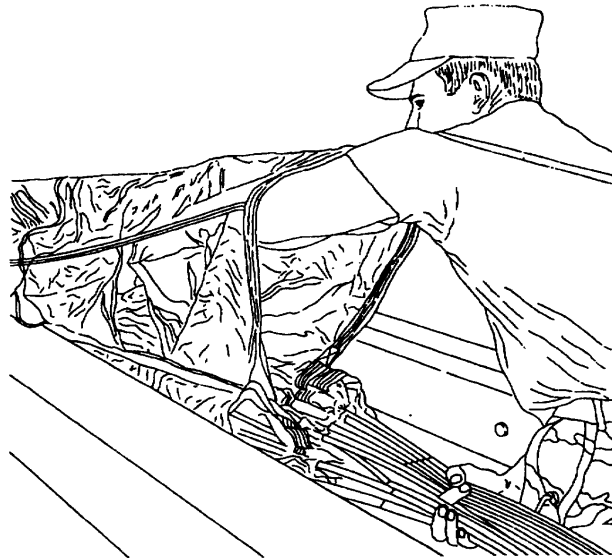

- l. Lower line 18 to right hand, drape gore 17 to right and gore 18 to left.
- m. Place line 18 between thumb and forefinger of right hand.
- n. Place two suspension line groups into a line separator at a point just below canopy skirt.



- o. Using left hand, hold line separator and separated lines. Grasp radial tape with right hand and pull canopy off right side of pack table, allowing all folded gores to drape downward to side of table.

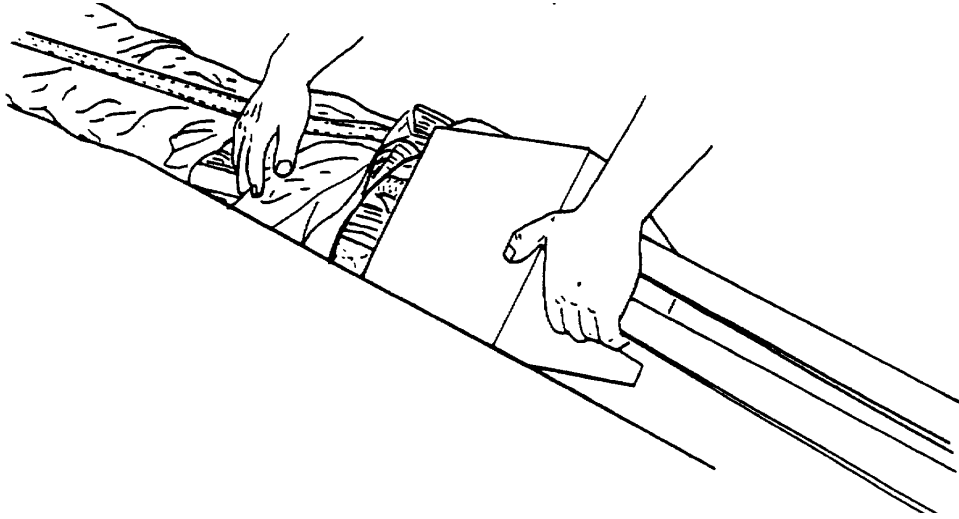

- p. Slide canopy back onto table and rotate suspension lines and line separator one-half turn counterclockwise, which will allow the line separator base to rest on the table. Lay a packing weight across the suspension lines just below the line separator.
- q. Apply additional tension and flip left group of gores to left side of tabletop.
- r. Using right hand, grasp top 17 gores of both groups.
- s. Dress the bottom gores of both groups.
- t. Work from vent reinforcement to skirt reinforcement to remove wrinkles from top gores, brush fingertips from radial seam toward folded edges.
- u. To complete the canopy flatfold, dress the gores and the skirt reinforcement (lower lateral band). Ensure that 18 gores are in each group and that a clear air channel exists between the two gore groups.

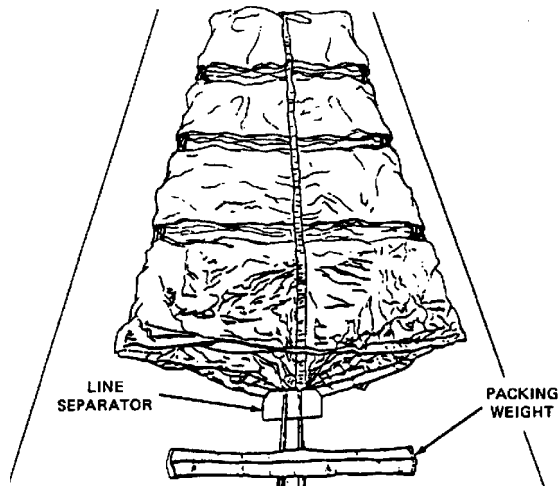

- v. Rigger check number 2.
- 2. Long fold.
  - a. Beginning with panel/section number 1, fold first six sections of right group of gores over radial seam 36 and fold left group over the right group.
  - b. Place packing weights of folded panel/sections to hold the folds in position. Ensure longfold does not exceed width of deployment bag.

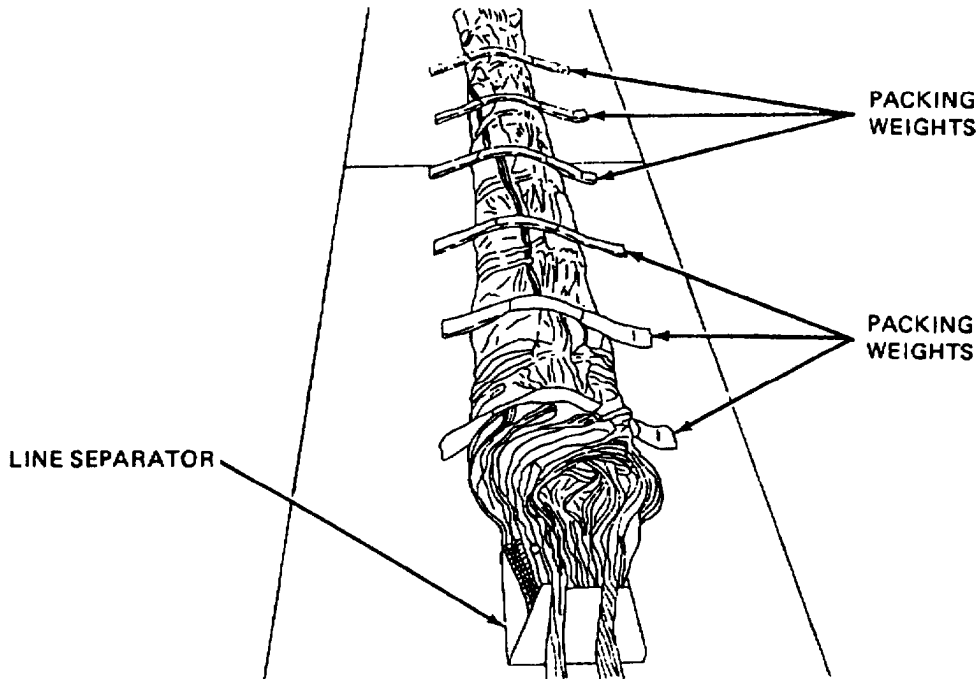

- 3. Rigger check number 3.
- 4. Attaching the canopy break cord tie. Attach the canopy break cord tie IAW procedures in WP 0004 00, ASSEMBLY OF THE 28-FOOT DIAMETER CARGO EXTRACTION PARACHUTE.
- 5. Stowing the canopy.

**NOTE**

An assistant packer will be required to ensure proper stowing of canopy.

- a. Wrap each suspension line connector link with two-inch wide, pressure sensitive adhesive cloth tape. Start at a point one-inch above the connector link and end at a point one-inch below the connector link. Wrap the tape twice around the entire length.
- b. Before stowing the canopy, install a sufficient number of double, 28-inch, type I, 1/4-inch cotton webbing girth hitch ties at equal intervals along the suspension line stowage flap stow loops.

- c. Beginning at upper right inside corner of deployment bag, stow canopy in the bag with S-fold.

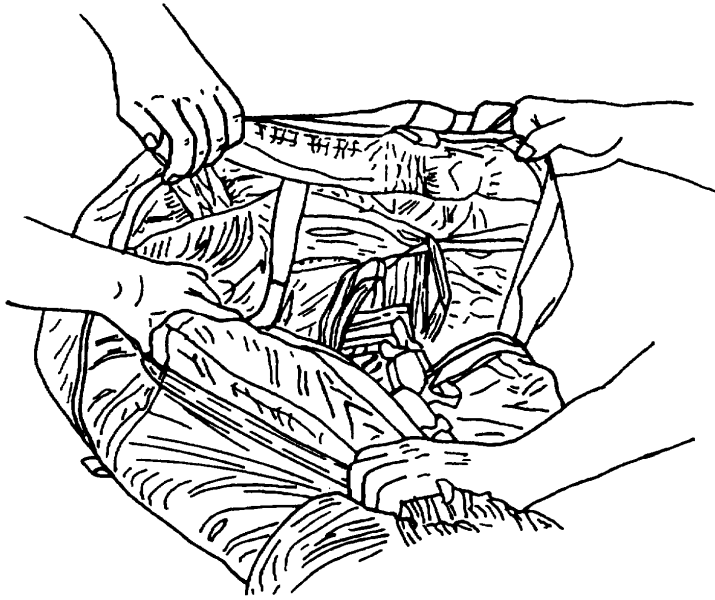

- d. Upon completion of canopy stowage, suspension lines should extend from left side of the bag open end.
- e. Fold suspension lines from left to right across skirt of canopy.
- f. Using one turn double ticket 8/7 cotton thread, secure top and bottom center bag, tie loops together by passing one thread end through bottom center tie loop from right to left, under suspension line fold, through the top center, tie loop from left to right and join thread ends on top of the suspension line fold with a surgeon's knot and a locking knot. Trim tie ends to 2-inches.

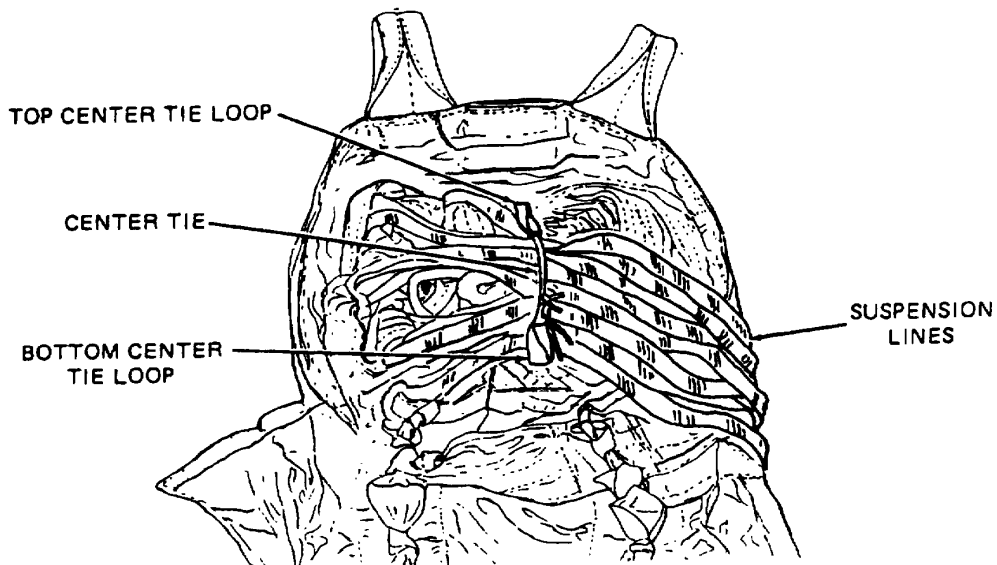

- g. Rigger check number 4.
- 6. Stowing the suspension lines.

NOTE

When making suspension line stows ensure stows do not exceed the width of the deployment bag. All suspension line stows on the 28-foot-diameter cargo extraction parachute will be secured with 1-turn double, type I ¼-inch cotton webbing and tied with a surgeon's knot and locking knot.

- a. To the right of secured center bag tie loops, form a loop in suspension lines and make the first suspension line stow at the upper right corner of the deployment bag suspension line stowage flap. Secure stow with the previously installed type I ¼-inch cotton webbing.

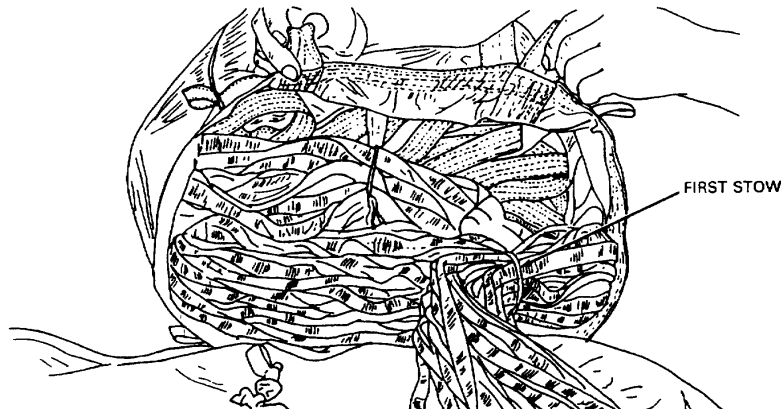

- b. Extend suspension lines to upper left corner of stowage flap, form a loop in the suspension line and secure stow with previously installed type I ¼-inch cotton webbing.
- c. Using procedures in (a) and (b) above, continue stowing suspension lines on stowage flap to a point within ten-inches of suspension line connector link assemblies. Make last stow at the lower right side of the stowage flap.

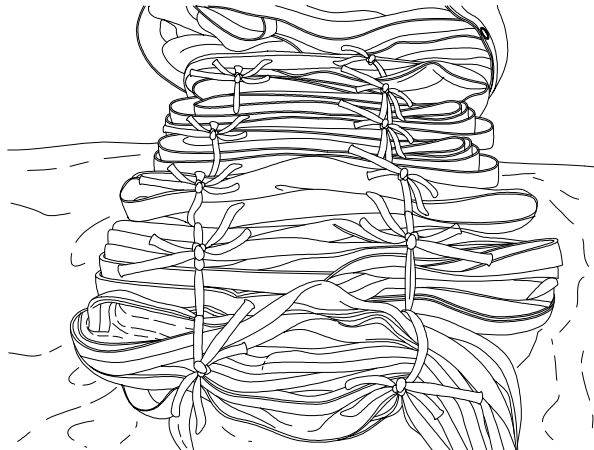

- d. Rigger check number 5.
7. Closing the deployment bag.
- a. Position suspension line connector link assemblies on inside center top of deployment bag. Extend adapter web from left side.
  - b. Cut an 11-foot length of type I, ¼-inch cotton webbing, fold in half twice forming a 2-foot 9-inch piece.
  - c. Girth hitch the 1-turn double, type I, ¼-inch cotton webbing around the adapter web above the connector links. Route one free end through the grommet (inside to outside) on the right side of the deployment bag forming an 8-inch loop. Secure with a surgeon's knot and locking knot.

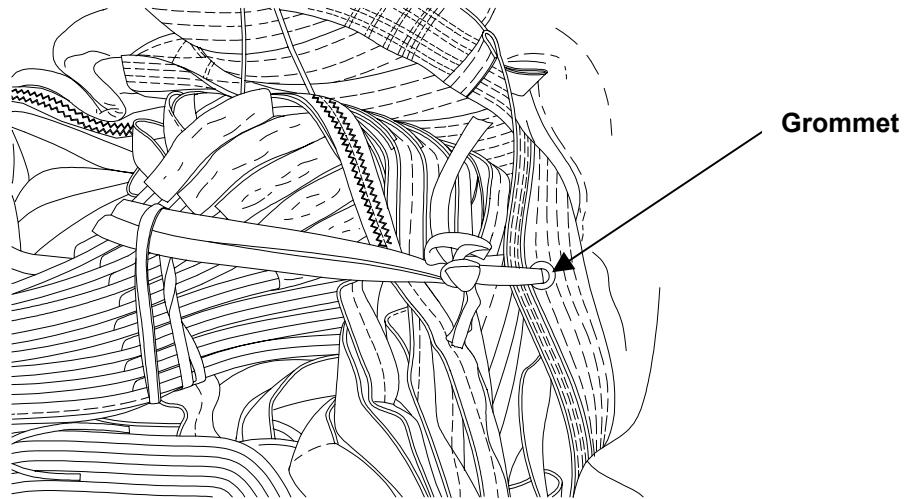

- d. Cut two 24-inch lengths of type I ¼-inch cotton webbing. S-fold the adapter web approximately the width of the storage flap and secure each S-fold with two, 24-inch lengths, 1-turn double, type I, ¼-inch cotton webbing, tying a surgeon's knot and locking knot.
- e. S-fold the remainder of the adapter webbing and secure it with a 1-turn double, 24-inch length of type I, ¼-inch cotton webbing with a surgeon's knot and locking knot.



- f. Take both s-folded sections and tie together with one turn single, type I, ¼-inch cotton webbing with a surgeon's knot and locking knot.

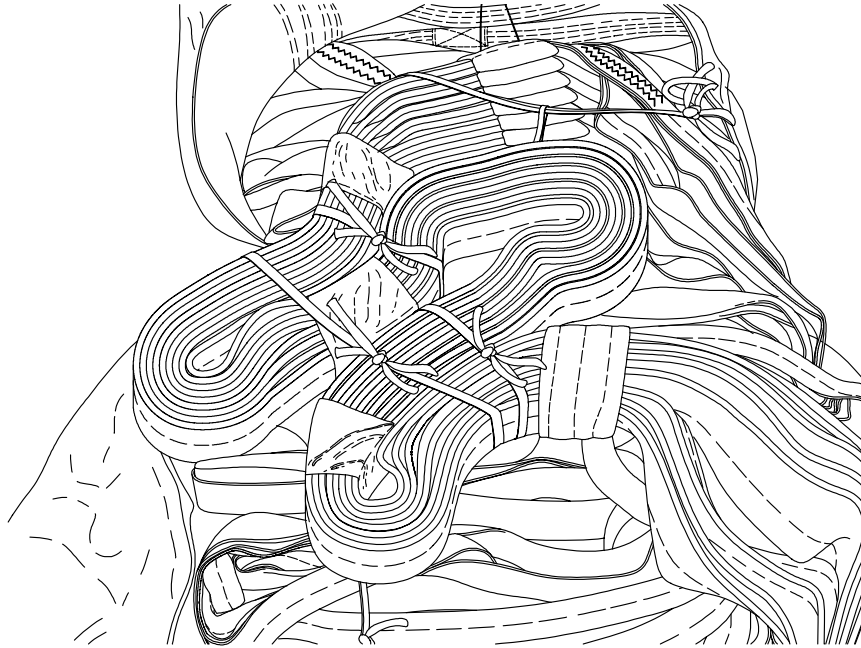

**NOTE**

Ensure that only four and a half feet of the adapter web extends from the deployment bag.

- g. Place the entire S-folded adapter webbing in the deployment bag. Be sure adapter web extends four and a half feet from left side of deployment bag.
- h. Fold right side of suspension line stowage flap over stowed suspension lines, fold left flap over right flap.



- i. Beginning at lower end of suspension line stowage flap, tightly roll flap into open end of deployment bag. Ensure four and a half feet of adapter web extends from left side of deployment bag.

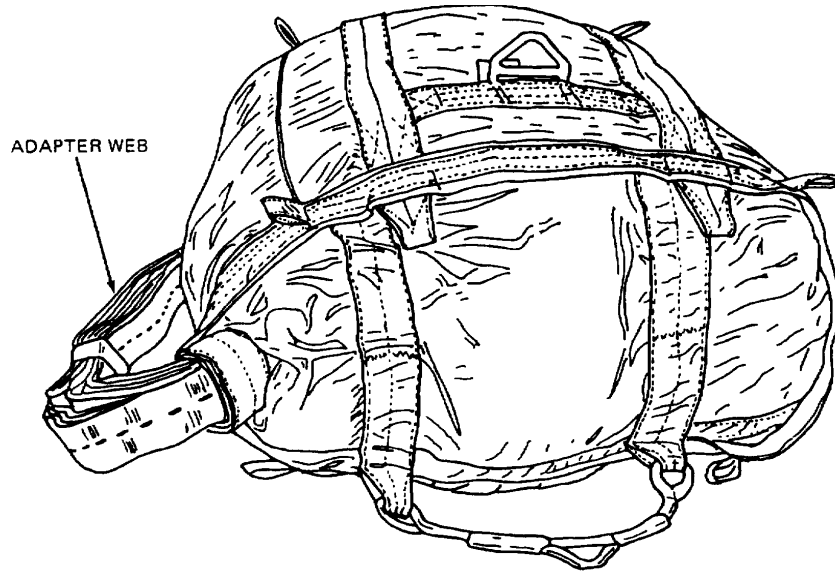

- j. Fold extended adapter web from left to right across rolled suspension line stowage flap.
- k. Using a length of doubled type I, 1/4-inch cotton webbing, make left bag closing tie by passing one end of webbing through left bottom bag closing loop from right to left, up behind adapter web, through top bag closing loop from left to right, secure ends together over adapter web, with a surgeon's knot and locking knot. Trim tie ends to 2-inches.
- l. Using a length of doubled type I, 1/4-inch cotton webbing, make right bag closing tie by passing one end of webbing through right bottom bag closing loop from left to right, up behind adapter web, up through right side bag grommet, through right bag closing loop from right to left, secure ends together over adapter web, with a surgeon's knot and locking knot. Trim tie ends to two-inches.

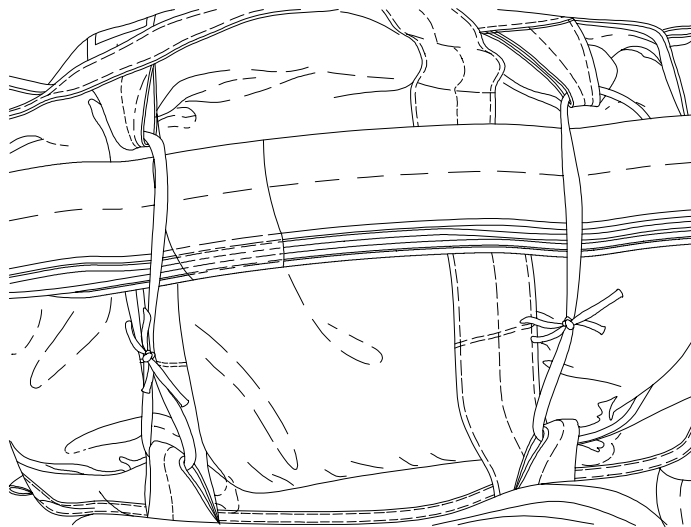

- m. Rigger check number 6.
- n. Tie the running end of the pendulum line to the canopy bridle loop with 3 alternating half hitches and an overhand knot in the running end. S-fold the excess and secure to the top of the deployment bag bridle straps with retainer bands.

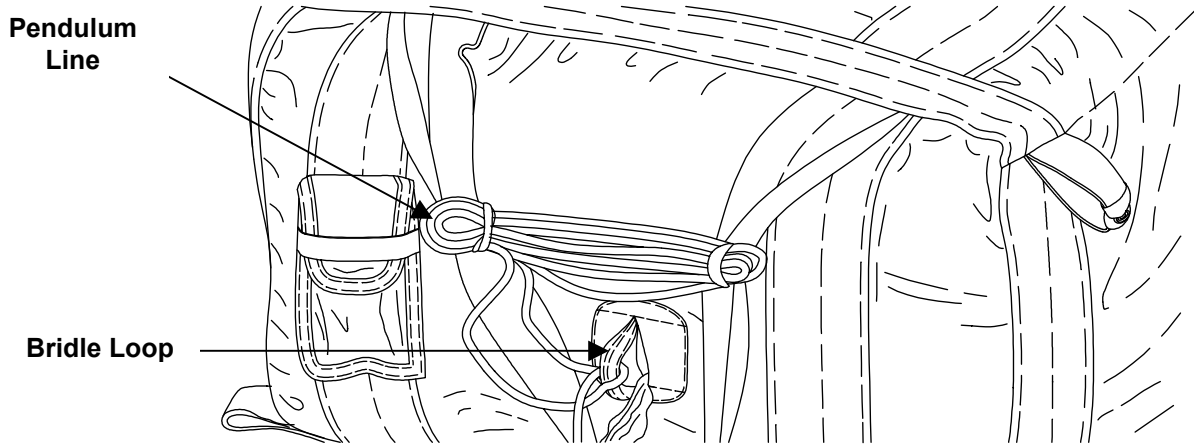

- o. Tape down the V-rings with 2-inch, pressure sensitive adhesive tape.

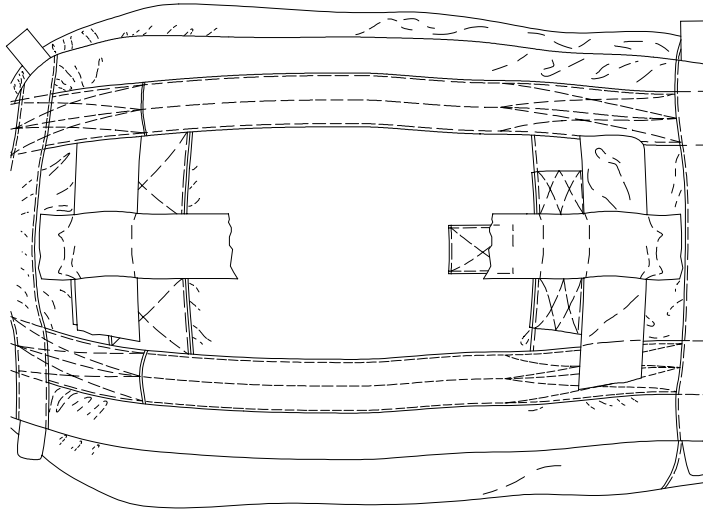

- 8. Signing DA Form 3912.
  - a. Remove parachute log record book from parachute inspection data pocket (log record pocket) on upper end of the deployment and record pack data as prescribed in WP 0003 00, SERVICE UPON RECEIPT.
  - b. After completion of entries, return log record book to inspection data pocket.
  - c. Rigger check number 7.



## PREPARING THE 28-FOOT DEPLOYMENT PARACHUTE WITH THE RELEASE AWAY STATIC LINE

1. Inspection. Inspect the release away static line as follows:
  - a. The release away static line for the 28-foot Deployment Parachute consists of a 12-foot static line with a 15-foot release line (made of  $\frac{1}{2}$ -inch tubular nylon) running through it, a 6-inch connector strap, and a 1-inch connector link.
  - b. Inspect the entire length of the outside of the sleeve for burns, cuts, tears and frays.
  - c. Check for loose or broken stitches, as well as missing or damaged hardware (grommets, 1-inch connector link).
  - d. Ensure the release line can move freely and there are no visible twists.
  - e. If burns or any other damage exists, discard and replace static line system; keep any salvageable hardware.

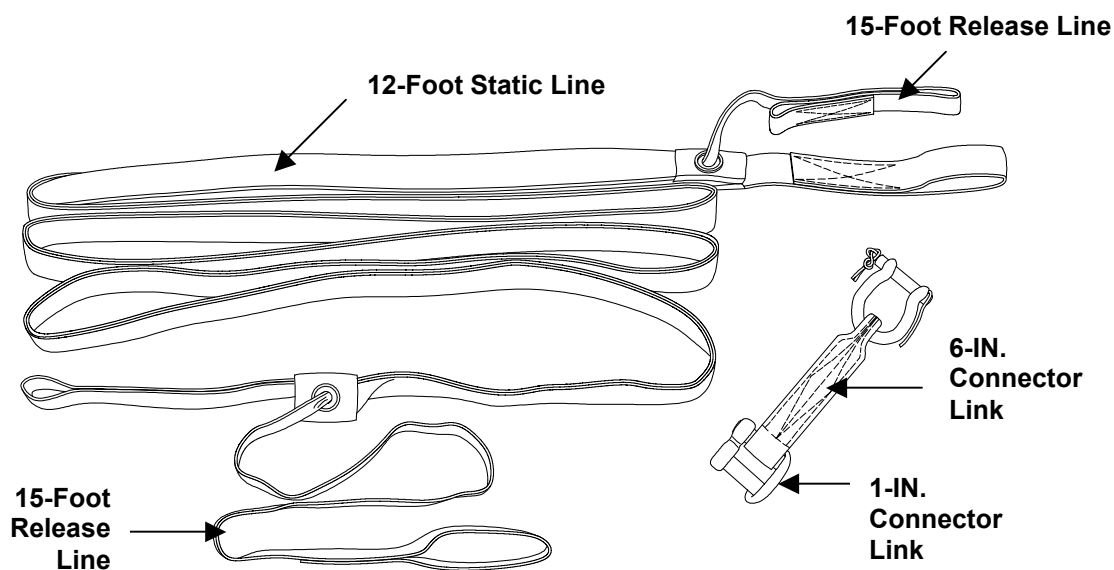

2. Assemble. Assemble the release away static line as follows:

### NOTE

Depending on the location of the load, assemble both left and right release away static lines.

- a. Pull the release line from its sleeve at the upper end until there are equal amounts of release line at both ends of the static line.
- b. Lay out the static line assembly with the release line facing up.
- c. Place a small (G-14) clevis on the end of the 6-inch connector strap.

- d. At end of static line that attaches to anchor line cable (the end with double looped release line), pass the top loop of the static line up through the 1-inch connector link on the 6-inch connector strap.

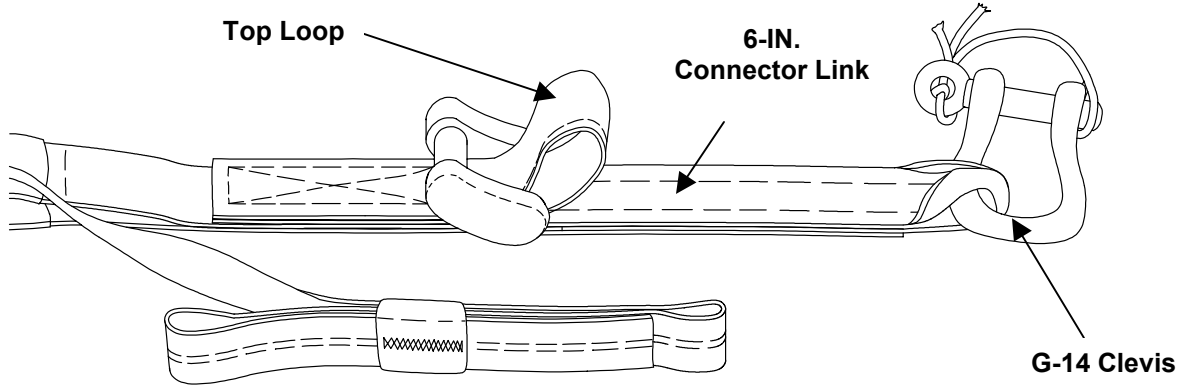

- e. Run the end loop of the release line through the loop in the static line from left to right or right to left, rigger's view, depending on the positioning of the load inside the aircraft.
- f. Using a tacking needle, run a length of single ticket 8/7-cotton thread through the running end (double looped end) of sewn portion of the release line. Pass one end of the single ticket 8/7, cotton thread through the 1-inch connector link and tie the loop with a surgeon's knot and locking knot ensuring there is no slack. Trim ends to within 2-inches.

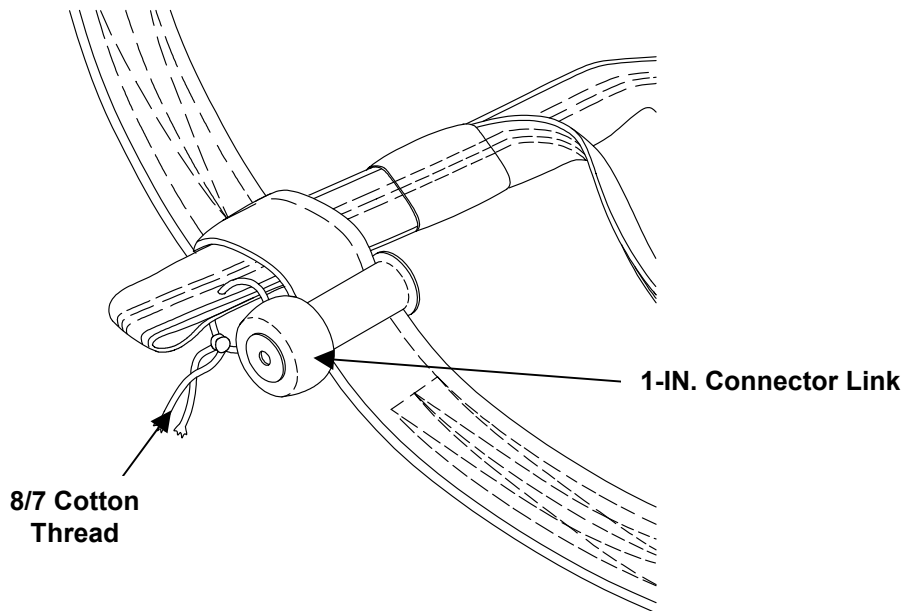

**NOTE**

Remove the slack in the release line to the end opposite the one that is tied with 8/7 cotton thread.

**NOTE**

Ensure that only the 1-inch connector link with flat screws and the G-14 small clevis are used with the 6-inch connector strap.

3. Attaching the Release Away Static Line to the 28-Foot Deployment Parachute.

- a. Route the free end of the static line behind both bag bridle straps and girth hitch the looped end of static line with grommet facing upward around both deployment bag bridle straps. Ensure that release line is not wrapped in the girth hitch.

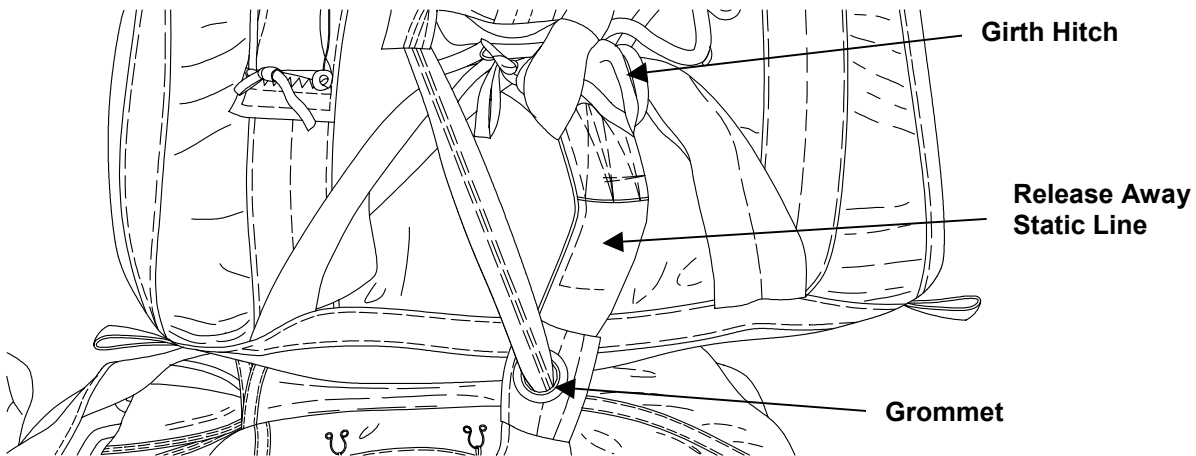

- b. Using 1-turn single 1/2-inch tubular nylon of suitable length, attach the canopy bridle loop to the release line (tied tightly) with a surgeon's knot and locking knot and an overhand knot in the running end. Cut the excess 1/2-inch tubular nylon, leaving 2-inch ends.

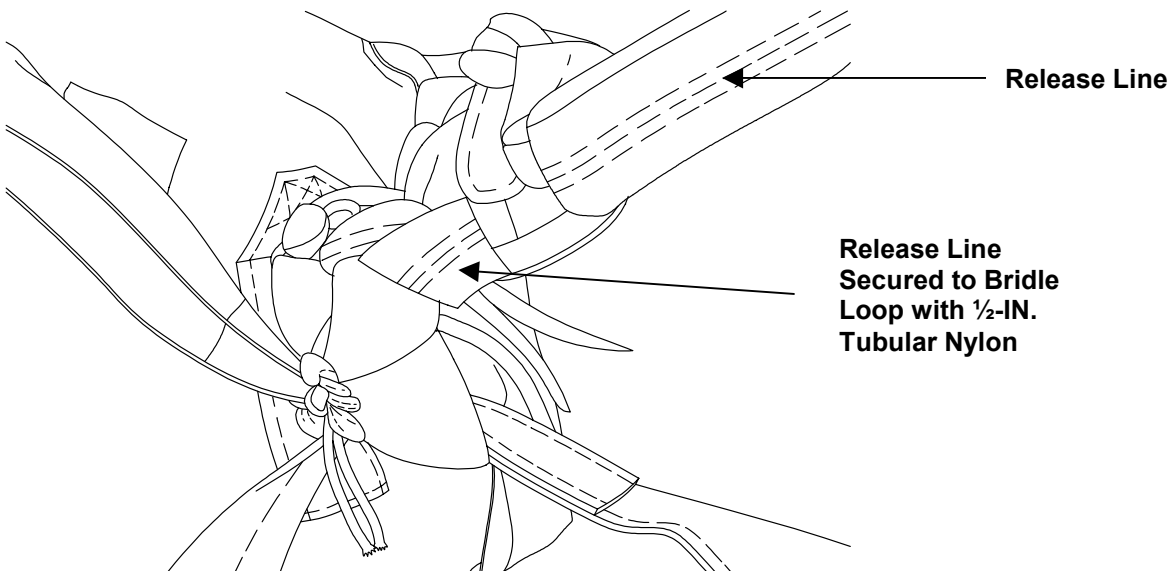

- c. S-fold remaining release line and secure with retainer band to itself.

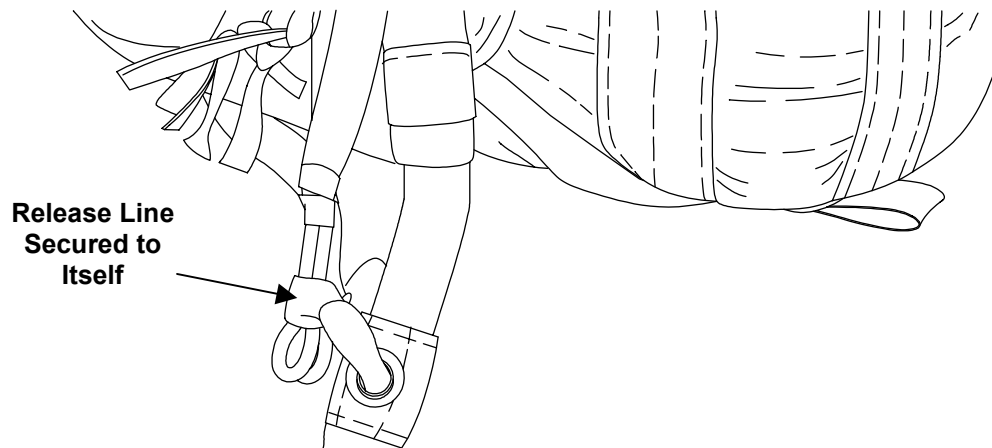

- d. S-fold rest of static line on top of the deployment bag and temporarily stow with retainer band on the top corner-clustering loop of the deployment bag.

**END OF WORKPACKAGE**

---

**UNIT MAINTENANCE**  
**28-FOOT DIAMETER CARGO EXTRACTION PARACHUTE**  
**SEWING PROCEDURES**

---

**THIS TASK COVERS:**

- Basting and Temporary Tacking
  - Stitching and Restitching
  - Darning
  - Zig-Zag Sewing
- 

**Tools**

Specified in paragraph applicable to the item being repaired.

**Materials/Parts**

Specified in paragraph applicable to the item being repaired.

**References**

DA PAM 738-751; WP 0013 00; WP 0065 00

**Personnel Required**

92R (10) Parachute Rigger

**Equipment Condition**

Unpacked. Cleaned canopy with defects recorded.

---

---

**NOTE**

---

Sewing requirements will vary according to the type of item being repaired and the type of repair being made. The type of sewing machine, type of thread, the stitch range, and the stitch pattern, if applicable, required to accomplish a sewing procedure will be specified in the paragraph applicable to the item being repaired. All original stitching that is cut during the performance of a sewing procedure will be removed from the applicable item. Immediately after the accomplishment of a machine sewing procedure, trim thread ends to a point as close as possible to the material that has been sewn.

**BASTING AND TEMPORARY TACKING**

Basting and temporary tacking are hand-sewing methods used to temporarily hold layers of cloth fabric together while a repair is being performed. The following is a list of procedures which apply to basting and temporary tacking actions:

1. Basting and temporary tacking should be made using thread that is of a contrasting color to the material being worked.
2. On small cargo parachute canopies, basting will be done using thread identified in individual item repair procedure.
3. When basting, do not tie knots at any point in the thread length. Also, the sewing should be done with two stitches per inch.
4. Temporary tacking will usually be done using a length of size E nylon thread (Item 23/24, WP 0065 00). However, an alternate type thread may be specified within the paragraph applicable to the item.
5. Immediately upon completion of a repair, remove previously made basting or temporary tacking stitches.

**STITCHING AND RESTITCHING**

Perform stitching and restitching as follows, referring to Table 1 and Table 2:

1. Parachute canopy assemblies. The stitching and restitching made on parachute canopies should be accomplished with thread that is contrasting in color to the fabric being restitched. If contrasting color thread is not available, thread of matching color may be used, providing all other specifications are met. Straight stitching and restitching on parachute canopy assemblies should be locked by at least 2-inches at each end of a stitch row, when possible. Zig-zag stitching does not require locking; however, zig-zag restitching should extend at least ¼-inch into undamaged stitching at each end, when possible. When restitching parachute canopy assemblies, stitch directly over the original stitching and follow the original stitch pattern as closely as possible.

**Table 1. Sewing Machine Code Symbols**

CODE SYMBOL	SEWING MACHINE
LD	SEWING MACHINE, INDUSTRIAL: General sewing; 301 stitch; light-duty; NSN 3530-01-177-8590.
MD ZZ	SEWING MACHINE, INDUSTRIAL: Zig-zag; 308 stitch; medium-duty; NSN 3530-01-181-1421.
LD ZZ	SEWING MACHINE, INDUSTRIAL: Zig-zag; 308 stitch; light-duty; NSN 3530-01-181-1420.
HD	SEWING MACHINE, INDUSTRIAL: General sewing; 301 stitch; heavy-duty; NSN 3530-01-177-8588.
MD	SEWING MACHINE, INDUSTRIAL: General sewing; 301 stitch; medium-duty; NSN 3530-01-177-8591.
DN	SEWING MACHINE, INDUSTRIAL: Darning; lock stitch; NSN 3530-01-177-8589.
LHD	SEWING MACHINE, INDUSTRIAL: 301 stitch; light, heavy-duty; NSN 3530-01-186-3079.
ND	SEWING MACHINE, INDUSTRIAL: 301 stitch; double needle; NSN 3530-01-182-2873.

**Table 2. Stitching and Restitching Specifications**

COMPONENT	RECOMMENDED SEWING MACHINE (CODE SYMBOL)	STITCHES PER INCH	THREAD SIZE
The 28-Foot-Diameter Cargo Extraction Parachute			
Canopy	LD DN	7 to 11 Darn	E E
Bridle entering line	ZZ	7 to 11	E
Suspension line	MD	5 to 8	3
Vent line	ZZ	7 to 11	FF
Bridle loop	HD	5 to 8	3
Suspension Line Attaching Loop	MD	7 to 11	FF
Pocket band	MD	7 to 11	FF
Radial tape	LD	7 to 11	E
Section reinforcement band	LD	7 to 11	E
Skirt reinforcement band (Lower lateral band)	LD	7 to 11	E
Vent reinforcement band (Upper lateral band)	MD	5 to 8	3
Vertical tape	ZZ	7 to 11	E
Deployment Bag			
Bag bridle strap	MD	7 to 11	FF
Retainer band keeper	MD	7 to 11	FF
V-ring keeper	HD	7 to 11	FF
Bent V-ring keeper	HD	7 to 11	3
Bag closing loop	HD	7 to 11	3
Log Record Book Pocket	MD/ZZ	7 to 11	FF
End slot reinforcement	MD	7 to 11	FF
Retainer band keeper reinforcement	MD	7 to 11	FF
Tie loop reinforcement	MD	7 to 11	FF
Tie loop	MD	7 to 11	FF
Edge binding	MD	7 to 11	FF
Main strap	MD	7 to 11	E
Panels and flaps	MD	7 to 11	FF
Stowage flap edge reinforcement	DN	Darn	FF
Safety Cord	ZZ	7 to 11	FF
The 106-Inch-Long Adapter			
Short buffer	HD	4 to 6	6
Fixed keeper	HD	4 to 6	6
Sliding keeper	HD	4 to 6	6
Webbing Length	HD	4 to 6	6

- a. Other parachute items. Stitching and restitching on other parachute items constructed from cloth, canvas, and webbing should be accomplished with thread that matches the color of the original stitching, when possible. Backstitching at least ½-inch should lock all straight stitching. Restitching should be locked by overstitching each end of the stitch formation by ½-inch. Zig-zag stitching does not require locking; however, zig-zag restitching should extend at least ¼-inch into undamaged stitching at each end, when possible. Restitching should be made directly over the original stitching, following the original stitch pattern as closely as possible.
2. Darning. (Refer to Tables 1 and Table 2.) Darning is a sewing procedure used to repair limited size holes, rips, and tears in assorted airdrop items constructed from textile material such as parachute canopy gore sections and the cloth and reinforcement webbing of packs. A darning repair may be made either by hand or sewing machine, depending upon the method preferred and the availability of equipment. However, a darning machine should be used to darn small holes and tears where fabric is missing. Darning of previously patched material can be performed provided darning size limitations prescribed in the paragraph applicable to the item are not exceeded. A darning repair will be performed using the following procedures, as appropriate:

a. Machine darning. Proceed as follows:

- (1) Using an authorized marking aid of contrasting color, mark a square around the damaged area and ensure that the marking is at least ¼-inch back from each edge of the damaged area. The marking will be made with the warp and the filling of the material.
- (2) Darn the damaged area by sewing the material in a back-and-forth manner, using size A or E nylon thread, allowing the stitching to run with the warp or filling of the fabric.

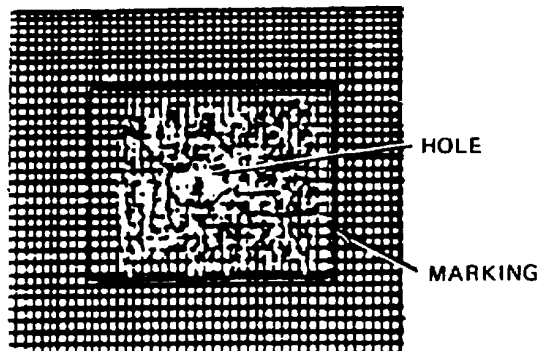

- (3) Turn the material and stitch back and forth across the stitching made in (b) above until the hole or tear is completely darned.

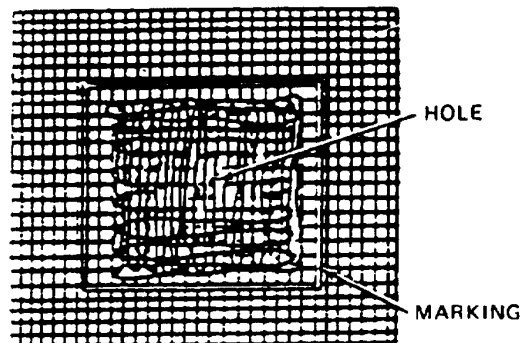



- (4) If applicable, restencil informational data, gore number(s), or identification marks using the criteria in WP 0013 00, SEARING AND WAXING.
- b. Hand darning. When repair of a hole or tear is made by hand darning, the darn should match the original weave of the damaged material as closely as possible. Hand darning will be performed as follows:
- (1) Using an authorized marking aid of contrasting color, mark a square around the damaged area and ensure that the marking is at least ¼-inch back from edge of the damaged area. The marking will be made with the warp and the filling of the material.
  - (2) Using a darning needle and a length of size A or E nylon thread, begin darning at one corner of the marked area. Working in the direction of the fabric warp or filling, pass the needle and thread back and forth, through the material until the opposite diagonal corner of the marked area is reached.

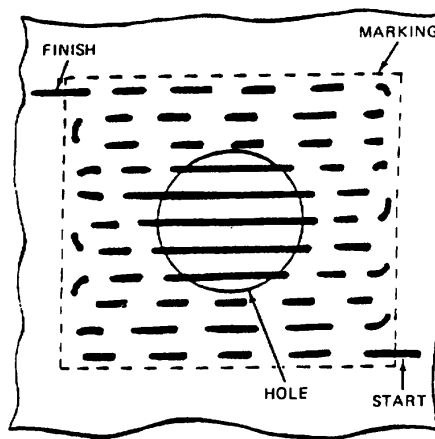

- (3) Turn the material and weave the needle and thread back and forth across the stitching made in (b), above, until the hole is completely darned.

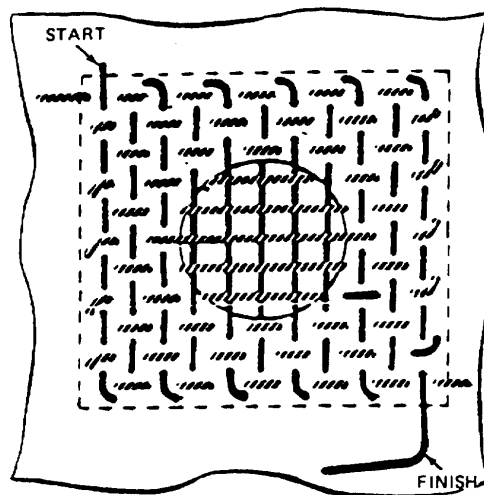

(4) If applicable, restencil informational data or identification marks as outlined in WP 0013 00, SEARING AND WAXING.

3. Zig-Zag Sewing. (Refer to Table 1 and Table 2.) Airdrop items, except parachute canopies, made from textile materials that have sustained cut or tear damage may be repaired by zig-zag sewing provided the applicable damaged area does not have any material missing and the cut or tear is straight or L-shaped. Should the damaged area be irregular shaped or have material missing, the repair will be achieved by either darning or patching, as required. A zig-zag sewing repair will be accomplished with a zig-zag sewing machine, using the following procedures:

- a. Set the sewing machine to the maximum stitch width.
- b. Beginning at a point 1/4-inch beyond one end of the cut or tear, stitch lengthwise along the damaged area to a point 1/4-inch beyond the opposite end of the cut or tear.



**STRAIGHT CUT OR TEAR STITCHING**

- c. The cited stitching procedure will also apply to an L-shaped cut or tear.

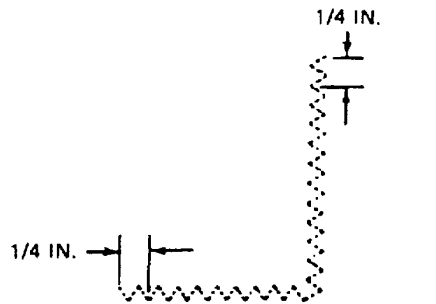

**L-SHAPED CUT OR TEAR STITCHING**

- d. If applicable, restencil informational data or identification marks as prescribed in WP 0013 00, SEARING AND WAXING.

**END OF WORK PACKAGE**

---

**UNIT MAINTENANCE**  
**28-FOOT DIAMETER CARGO EXTRACTION PARACHUTE**  
**SEARING AND WAXING**

---

**THIS TASK COVERS:**

- Searing
  - Waxing
- 

**Tools**

Pot, Melting, Electric (Item 13, WP 0056 00)  
Knife, Hot, Metal (Item 6, WP 0056 00)

**Materials/Parts**

Beeswax, Technical (Item 2, WP 0065 00)  
Wax, Paraffin, Technical (Item 34, WP 0065 00)

**Personnel Required**

92R (10) Parachute Rigger

**Equipment Condition**

Unpacked.

---

---

**CAUTION**

---

Cotton tape, webbing, or cord will not be seared.

---

**NOTE**

---

Fabric materials such as cord, tape, and webbing, that are cut for use in the maintenance of parachutes will normally be heat-seared or dipped in a melted wax mixture, as applicable, to prevent the material from fraying or unraveling. However, in some instances the preparation of the material may not be necessary and will be specified accordingly.

**SEARING**

The cut ends of nylon tape, webbing, and cord lengths may be prepared by heat-searing; this is performed by pressing the raw end of the material against a hot metal surface (knife) until the nylon has melted sufficiently. Avoid forming a sharp edge or lumped effect on the melted end.

**WAXING**

The fraying or unraveling of cotton or nylon tape, webbing, and cord length ends may be prevented by dipping ½-inch of the raw end of the material into a thoroughly melted mixture of half beeswax and half paraffin in an electric melting pot. The wax temperature should be substantial enough to ensure the wax completely penetrates the material rather than just coating the exterior fabric.

**END OF WORK PACKAGE**

**THIS PAGE INTENTIONALLY LEFT BLANK**

---

**UNIT MAINTENANCE**  
**28-FOOT DIAMETER CARGO EXTRACTION PARACHUTE**  
**MARKING AND RESTENCILLING**

---

**THIS TASK COVERS:**

- Marking
  - Restencilling
  - Remarking and Restencilling
- 

**Tools**

Brush, Stencilling (Item 3, WP 0056 00)  
Knife (Item 5, WP 0056 00)  
Machine, Stencil Cutting (Item 8, WP 0056 00)

**Materials/Parts**

Ink, Marking, Parachute, Strata-Blue (Item 10, WP 0065 00)  
Marker, Felt Tip, Black (Item 13, WP 0065 00)  
Pen, Ballpoint (Item 14, WP 0065 00)  
Stencilboard, Oiled (Item 16, WP 0065 00)

---

**Personnel Required**

92R (10) Parachute Rigger

**Equipment Condition**

Laid out on packing table or other suitable area.

---

**NOTE**

---

Stenciling should be used whenever possible. A ballpoint pen or felt tip marker should be used only where stenciling is not possible, or when stenciling devices are not available. Any type ballpoint pen using black or blue ink may be used for marking on labels only. Original stenciled data or marking that becomes faded, illegible, obliterated, or removed as a result of performing a repair procedure will be remarked with a ballpoint pen, felt tip marker, or restenciled. All marking or restenciling will be done on, or as near as possible to, the original location and should conform to the original lettering type and size.

**MARKING**

Using marking devices, such as ballpoint pen or felt tip marker, mark on, or as near as possible to, original location and conform to original lettering type and size.

**RESTENCILING**

Proceed as follows:

1. Cut oiled stencilboard to original lettering type and size of data to be restenciled.
2. Place cut stencilboard over, or as near as possible to, original marking to be restenciled.
3. Place additional sheet of stencilboard beneath the area to be restenciled to prevent the marking ink from penetrating to the areas.
4. Hold stencilboard in place and, using stenciling brush filled with parachute marking ink, restencil original marking.

**REMARKING AND RESTENCILING**

Remark or restencil original stenciled data or markings that become faded, illegible, obliterated or have been removed as a result of performing a repair procedure. Ensure all marking or restenciling is on, or as near as possible to, the original location and conforms to the original lettering type and size.

**END OF WORK PACKAGE**

**UNIT MAINTENANCE  
28-FOOT DIAMETER CARGO EXTRACTION PARACHUTE  
PARACHUTE CANOPY**

---

**THIS TASK COVERS:**

- Repair
  - Replace
- 

**Equipment Condition**

Cleaned (WP 0008 00).  
Inspected (WP 0009 00).  
Unpacked, canopy laid flat.

**Personnel Required**

92R (10) Parachute Rigger

**References**

WP 0056 00 and 0057 00, MAC

---

**REPAIR**

Refer to individual component/assembly repairs and replacement procedures and MAC, WP 0056 00 and WP 0057 00.

**REPLACE**

Replace an unrepairable parachute canopy with a serviceable parachute canopy from stock.

**END OF WORK PACKAGE**

**THIS PAGE INTENTIONALLY LEFT BLANK**



**UNIT MAINTENANCE**  
**28-FOOT DIAMETER CARGO EXTRACTION PARACHUTE**  
**ATTACHMENT LOOP (BRIDLE LOOP)**

**THIS TASK COVERS:**

- Repair
- Replace

**Tools**

Knife (Item 5, WP 0056 00)  
 Pot, Melting, Electric (Item 13, WP 0056 00)  
 Sewing Machine, Heavy-Duty (Item 20, WP 0056 00)  
 Shears (Item 24, WP 0056 00)  
 Yardstick (Item 26, WP 0056 00)

**Personnel Required**

92R (10) Parachute Rigger

**Equipment Condition**

Cleaned (WP 0008 00).  
 Inspected (WP 0009 00).  
 Unpacked, canopy laid flat.

**Materials/Parts**

Marker, Felt-Tip, Black (Item 13, WP 0065 00)  
 Thread, Nylon, Size 3, OD (Item 25, WP 0065 00)  
 Webbing, Cotton, Type X, OD (Item 37, WP 0065 00)

**REPAIR**

Repair an attachment loop requiring restitching as follows:

1. Use a heavy-duty sewing machine to restitch any loose or broken stitches.
2. Restitch over original stitch pattern using size 3, nylon thread. Overstitch  $\frac{1}{2}$ -inch to lock stitches.

**REPLACE**

Replace a damaged or missing attachment loop as follows:

1. Cut a 20-inch length of type X cotton webbing.
2. Using a marking aid, mark webbing length at a point 5-inches from each end.
3. Between two 5-inch marks made in 2. above, roll  $\frac{1}{2}$ -inch of each webbing into center of webbing width and allow webbing edges to overlap. Secure overlapped webbing edges to webbing length by stitching a single row of stitching along the center of webbing overlap and  $1\frac{1}{2}$ -inches along each rolled edge beyond point of edge overlap. Stitching will be 5 to 8 stitches per inch.

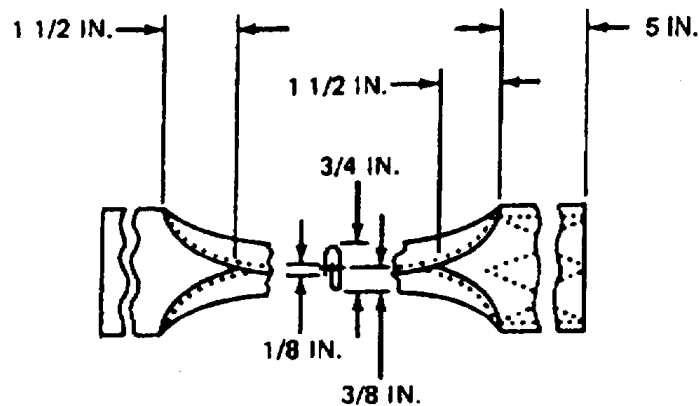

4. Pass one webbing end through vent lines and join webbing ends together above vent lines with a 5-inch long overlap. Ensure the webbing length encircles all vent lines.

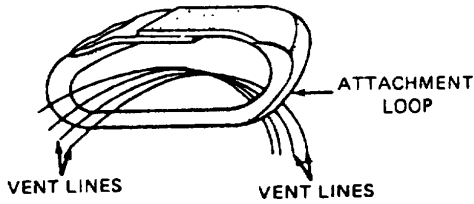

Side View

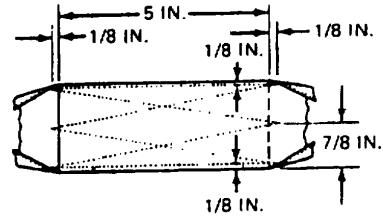

Top View

5. Secure overlapped webbing ends together by stitching a 5-inch long, three-point WW-stitch formation, with a  $\frac{1}{8}$ -inch over stitch on each webbing end. Stitching will be 5 to 8 stitches per inch.
6. Remove original attachment loop (bridle loop) by cutting loop webbing as required.

**END OF WORK PACKAGE**

---

**UNIT MAINTENANCE**  
**28-FOOT DIAMETER CARGO EXTRACTION PARACHUTE**  
**VENT LINES**

---

**THIS TASK COVERS:**

- Repair
- 

**Tools**

Sewing Machine, Zig-Zag (Item 23, WP 0056 00)  
Shears (Item 24, WP 0056 00)

**Materials/Parts**

Thread, Nylon, Size FF (Item 32/33, WP 0065 00)

**Personnel Required**

92R (10) Parachute Rigger

**Equipment Condition**

Cleaned (WP 0008 00).  
Inspected (WP 0009 00).  
Unpacked, canopy laid flat.

---

**REPAIR**

Repair vent lines requiring restitching as follows:

1. Use a zig-zag sewing machine to restitch any loose or broken stitches.
2. Restitch over original stitch pattern using nylon thread, size FF. Overstitch ¼-inch to lock stitches.

**END OF WORK PACKAGE**

**THIS PAGE INTENTIONALLY LEFT BLANK**

---

**UNIT MAINTENANCE**  
**28-FOOT DIAMETER CARGO EXTRACTION PARACHUTE**  
**BRIDLE CENTERING LINE**

---

**THIS TASK COVERS:**

- Repair
- 

**Tools**

Sewing Machine, Zig-Zag (Item 23, WP 0056 00)  
Shears (Item 24, WP 0056 00)

**Materials/Parts**

Thread, Nylon, Size E (Item 30/31, WP 0065 00)

**References**

WP 0012 00

---

**Personnel Required**

92R (10) Parachute Rigger

**Equipment Condition**

Cleaned (WP 0008 00).  
Inspected (WP 0009 00).  
Unpacked, canopy laid flat.

**REPAIR**

Restitch broken or loose thread using a zig-zag sewing machine and size E nylon thread (Refer to Table 2, Stitching and Restitching Specifications, WP 0012 00). Stitch over original stitch pattern. Overstitch ¼-inch to lock stitches.

**END OF WORK PACKAGE**

**THIS PAGE INTENTIONALLY LEFT BLANK**

---

**UNIT MAINTENANCE**  
**28-FOOT DIAMETER CARGO EXTRACTION PARACHUTE**  
**VENT REINFORCEMENT BAND (UPPER LATERAL BAND)**

---

**THIS TASK COVERS:**

- Repair
- 

**Tools**

Knife (Item 5, WP 0056 00)  
 Knife, Hot Metal (Item 6, WP 0056 00)  
 Pot, Melting, Electric (Item 13, WP 0056 00)  
 Sewing Machine, Heavy-Duty (Item 20, WP 0056 00)  
 Sewing Machine, Zig-Zag (Item 23, WP 0056 00)  
 Shears (Item 24, WP 0056 00)  
 Yardstick (Item 26, WP 0056 00)

**Personnel Required**

92R (10) Parachute Rigger

**Equipment Condition**

Cleaned (WP 0008 00).  
 Inspected (WP 0009 00).  
 Unpacked, canopy laid flat.

**References**

WP 0012 00, WP 0013 00

**Materials/Parts**

Beeswax, Technical (Item 2, WP 0065 00)  
 Marker, Felt-Tip, Black (Item 13, WP 0065 00)  
 Thread, Nylon, Size 3 (Item 24/25, WP 0065 00)  
 Thread, Nylon, Size E (Item 30/31, WP 0065 00)  
 Wax, Paraffin, Technical (Item 34, WP 0065 00)  
 Webbing, Nylon, Tubular, Type I, 1-IN. (Item 39, WP 0065 00)

---

**REPAIR**

1. Restitch broken or loose thread using a zig-zag sewing machine and size E nylon thread (Refer to Table 2, Stitching and Restitching Specifications, WP 0012 00). Stitch over original stitch pattern. Lock each row of stitches two-inches at each end.
2. Splicing. Repair as follows:

NOTE

Vent reinforcement bands may be spliced only once and will not be replaced.

- a. Damage between radial seams. Repair as follows:

- (1) Mark vent line position and cut stitching of two vent lines on each side of damaged area; move lines to one side.
- (2) Smooth canopy around damaged area.
- (3) Cut a piece of 1-inch tubular nylon webbing long enough to extend 1-inch beyond outside edge of second radial seam on each side of damaged area. Wax ends of webbing (WP 0013 00, SEARING AND WAXING).

- (4) Position webbing on damaged area. Use a heavy-duty sewing machine and size 3 nylon thread to stitch. Sew webbing in place with four continuous rows of stitching along the full length of the splice, 5 to 8 stitches per inch. Overstitch ends of webbing by 1/2-inch.

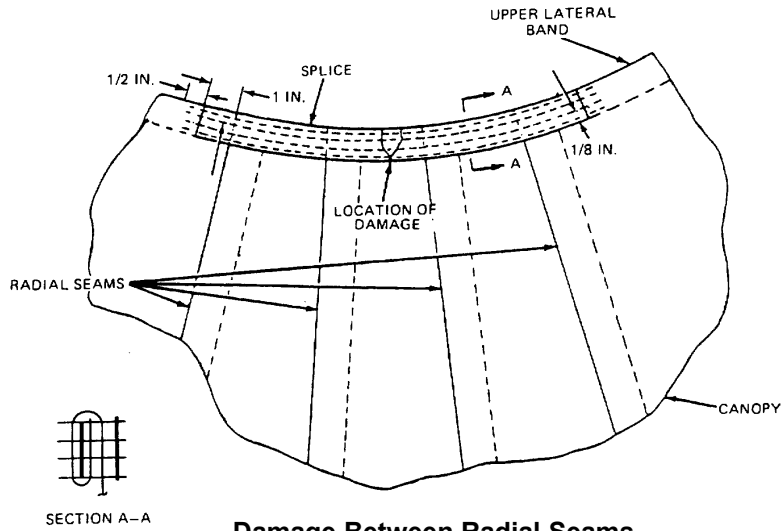

- (5) Reposition vent lines and sew them in place according to original construction.

b. Damage extending into radial seam. Repair as follows:

- (1) Mark vent line position and cut stitching of vent line attached to damaged radial seam and the stitching of two vent lines on each side of damaged seam. Move lines to one side.
- (2) Smooth canopy around damaged area.
- (3) Cut a piece of 1-inch tubular nylon webbing long enough to extend 1-inch beyond outside edge of second radial seam on each side of damaged area. Wax ends of webbing (WP 0013 00, SEARING AND WAXING).
- (4) Position tape on damaged area. Use a heavy-duty sewing machine and size 3 nylon thread to stitch. Sew webbing in place with four continuous rows of stitching along the full length of the splice, 1/8-inch from edge of tape, 5 to 8 stitches per inch. Overstitch ends of webbing by 1/2-inch.

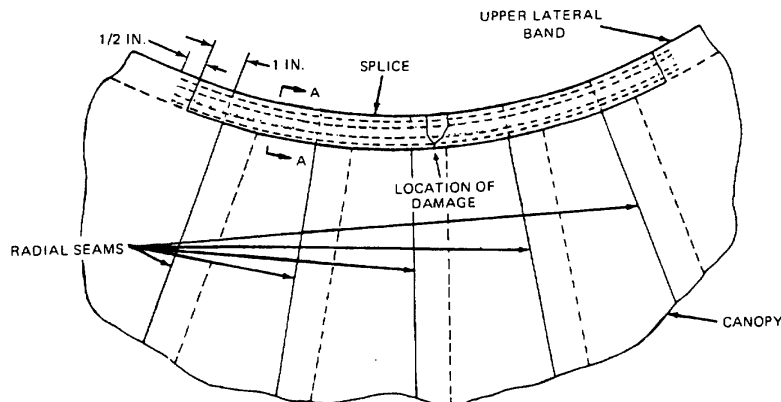



- (5) Reposition vent lines and sew in place according to original construction.

**END OF WORK PACKAGE**

**THIS PAGE INTENTIONALLY LEFT BLANK**

---

**UNIT MAINTENANCE**  
**28-FOOT DIAMETER CARGO EXTRACTION PARACHUTE**  
**GORE SECTION**

---

**THIS TASK COVERS:**

- Repair
- 

**Tools**

Brush, Stencilling (Item 3, WP 0056 00)  
 Knife (Item 5, WP 0056 00)  
 Needle, Tacking (Item 10, WP 0056 00)  
 Sewing Machine, Darning (Item 19, WP 0056 00)  
 Sewing Machine, Light-Duty (Item 21, WP 0056 00)  
 Shears (Item 24, WP 0056 00)  
 Yardstick (Item 26, WP 0056 00)

**Personnel Required**

92R (10) Parachute Rigger

**Equipment Condition**

Cleaned (WP 0008 00).  
 Inspected (WP 0009 00).  
 Unpacked, parachute laid out on table.

**Materials/Parts**

Cloth, Nylon, Parachute, Type II, 3.5 Oz. (Item 5, WP 0065 00)  
 Marker, China, White (Item 12, WP 0065 00)  
 Pushpins (Local Purchase)  
 Thread, Nylon, Size E (Item 30/31, WP 0065 00)

**References**

WP 0012 00 and WP 0014 00

---

**REPAIR**

1. Restitching. Stitching and restitching made on parachute canopies should be accomplished with size E nylon thread that is contrasting in color to the fabric being stitched or the original thread being restitched. If contrasting color thread is not available, thread of matching color may be used, providing all other specifications are met. Straight stitching and restitching should be locked by at least two-inches at each end of a stitch row, when possible. Restitch directly over the original stitching and follow the original stitch pattern as closely as possible.
2. Darning. Darn a hole or tear in a gore section that does not exceed  $\frac{3}{4}$ -inch in length or diameter as prescribed in WP 0012 00, SEWING PROCEDURES, using size E nylon thread. Each gore section may be darned three times.
3. Patching. Use a patch to repair holes that exceed  $\frac{3}{4}$ -inch in length or diameter using the sewn patch.
  - a. Sewn patches. There are two types of sewn patches authorized, the basic and miscellaneous. A basic patch is used to repair damaged cloth when the affected area is no closer than 1-inch from a radial webbing upper lateral band or lower lateral band. Should a damaged area be closer than 1-inch to the cited areas, a miscellaneous patch will be made.

---

**NOTE**

---

Sewn patches on the canopy will be applied to the inside and may be square or rectangular in shape.

When a miscellaneous canopy patch is used, cut stitching and remove or lay aside items that may interfere with patch application. Refer to applicable item repair paragraph for proper procedures.

- (1) Using a marking aid of contrasting color, mark a square or rectangle around area to be patched and ensure one side of marking square or rectangle is parallel to warp or filling of fabric.

- (2) Cut damaged area fabric along lines made in step (1) above. Further cut fabric diagonally at each corner to allow a 1/2-inch foldback in raw edges. Cut stitching and lay aside or remove any item that will interfere with miscellaneous patch application.
- (3) Make a 1/2-inch foldback on each raw edge. Pin and baste each foldback to complete prepared hole. Basting will be performed using procedures in WP 0012 00, SEWING PROCEDURES.

**NOTE**

Repair cloth for the 28-foot diameter extraction parachute is 3.5 oz nylon cloth.

- (4) Using nylon cloth, mark and cut a patch 2 1/2-inches wider and longer than inside measurements of prepared hole. Ensure patch material is marked and cut along warp or filling fabric.
- (5) Center patch material over prepared hole and ensure warp or filling of patch material matches warp or filling of fabric being patched. Pin patch material in position.
- (6) Make a 1/2-inch foldunder on each edge of patch material and baste patch to prepared area. Basting will be performed using procedures in WP 0012 00, SEWING PROCEDURES.
- (7) Remove pushpins securing item to the repair table and secure patch by stitching, using the applicable details in the illustrations on the following pages and the stitching specifics outlined in Table 2, WP 0012 00. Make first row of stitching completely around patch. Invert canopy and make a second row of stitching around prepared hole. Stitching will be performed in accordance with WP 0012 00.
- (8) Replace items removed for miscellaneous patch, as required, in accordance with applicable item procedures.

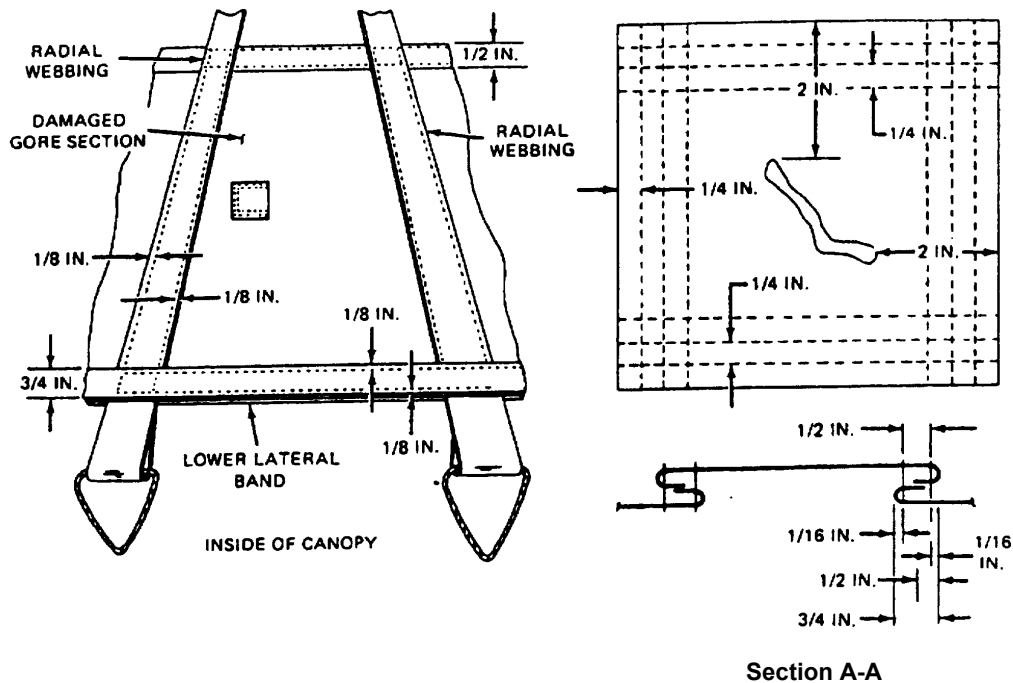

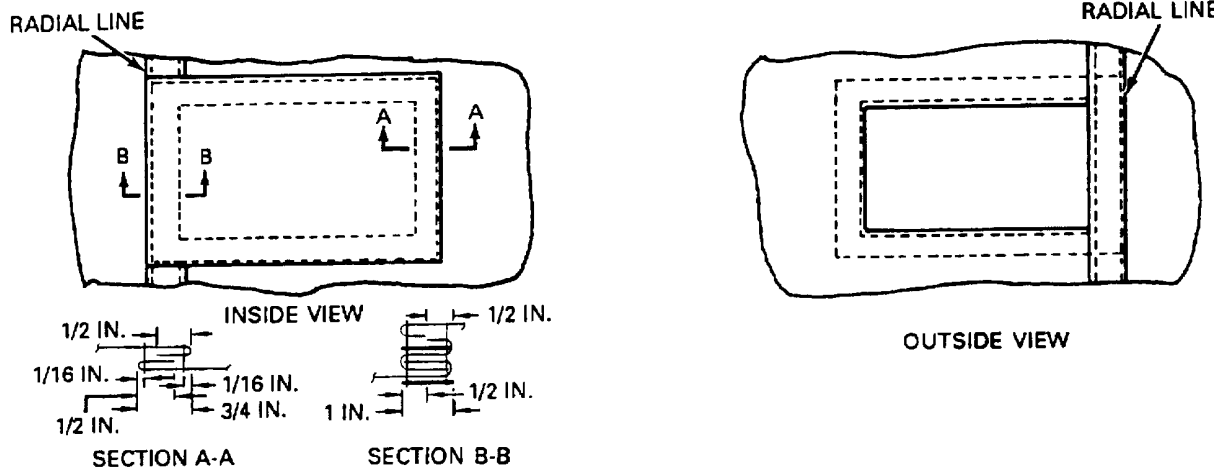
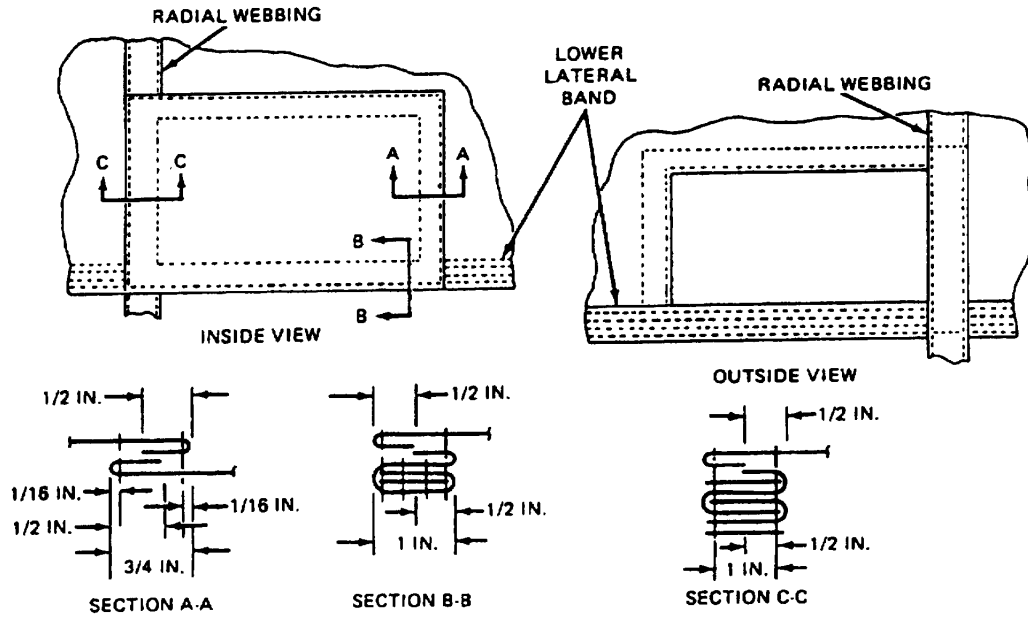

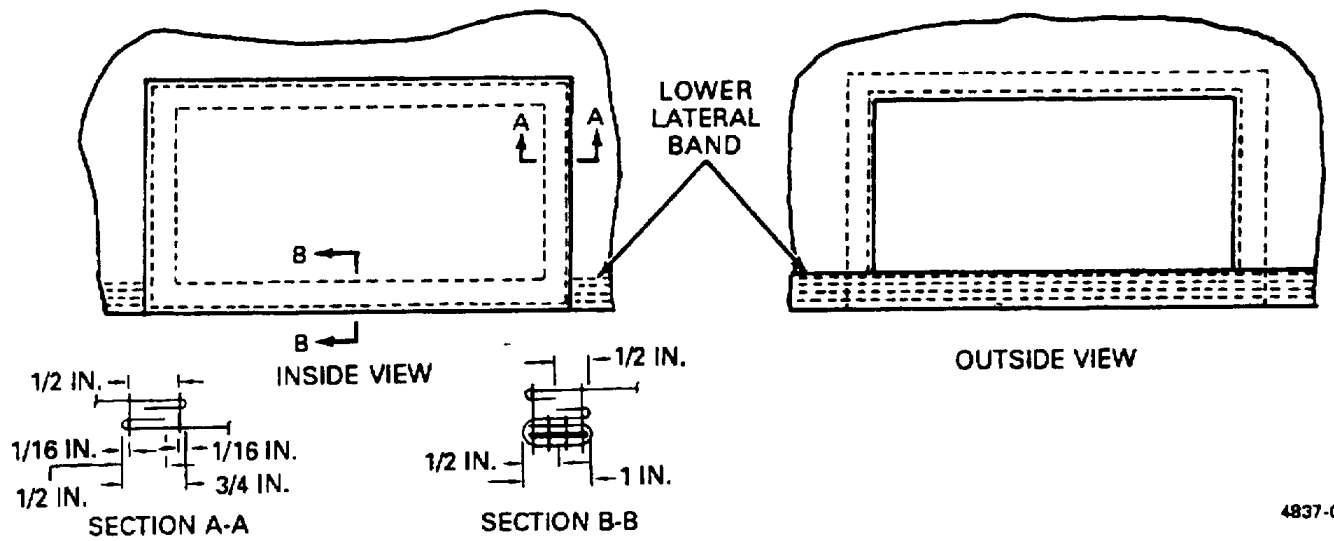
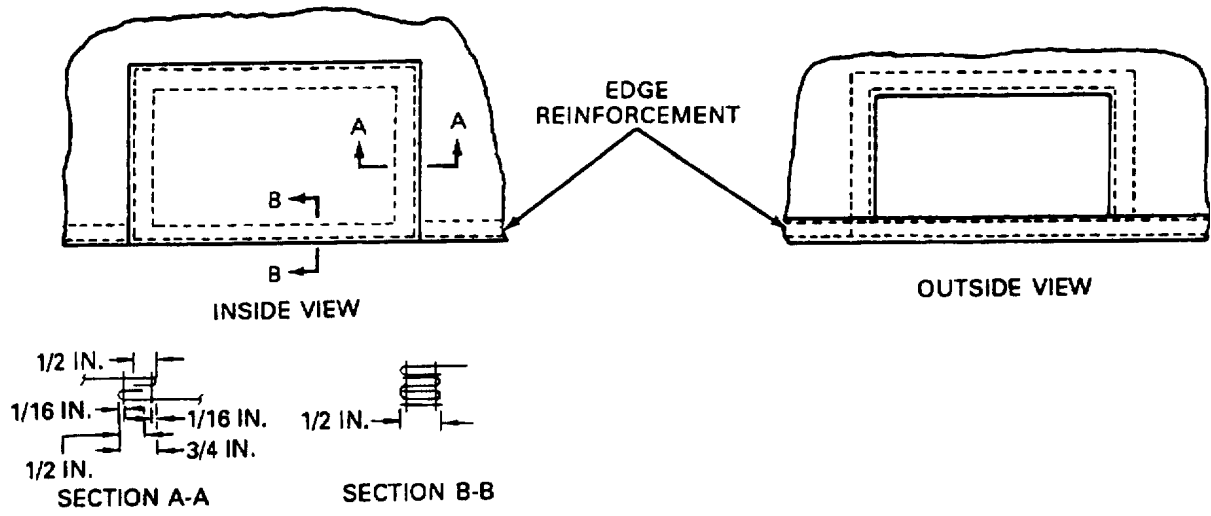

4837-0

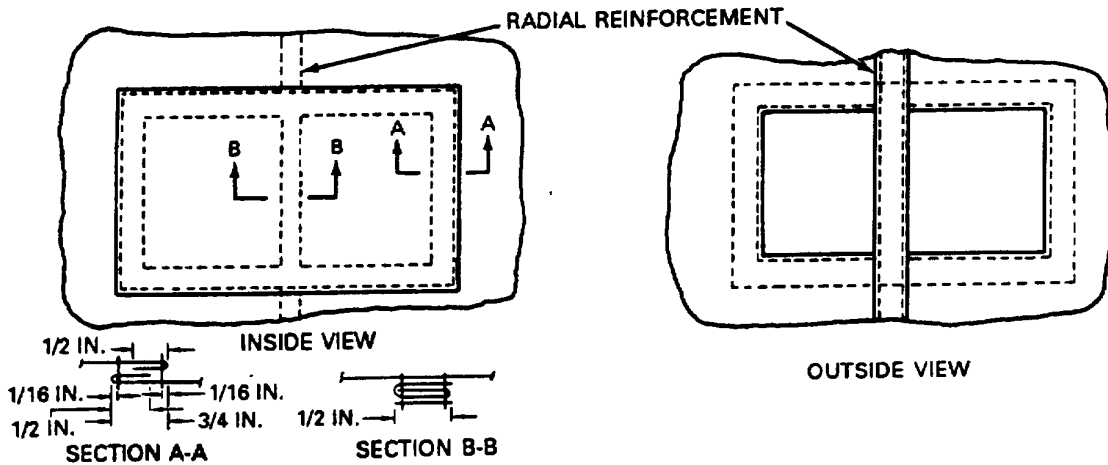
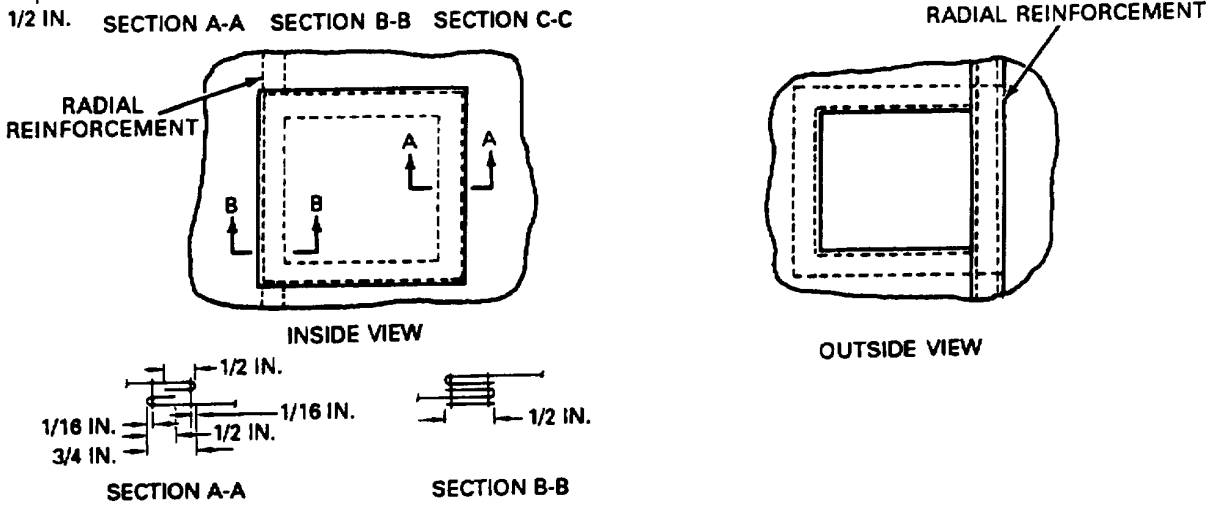
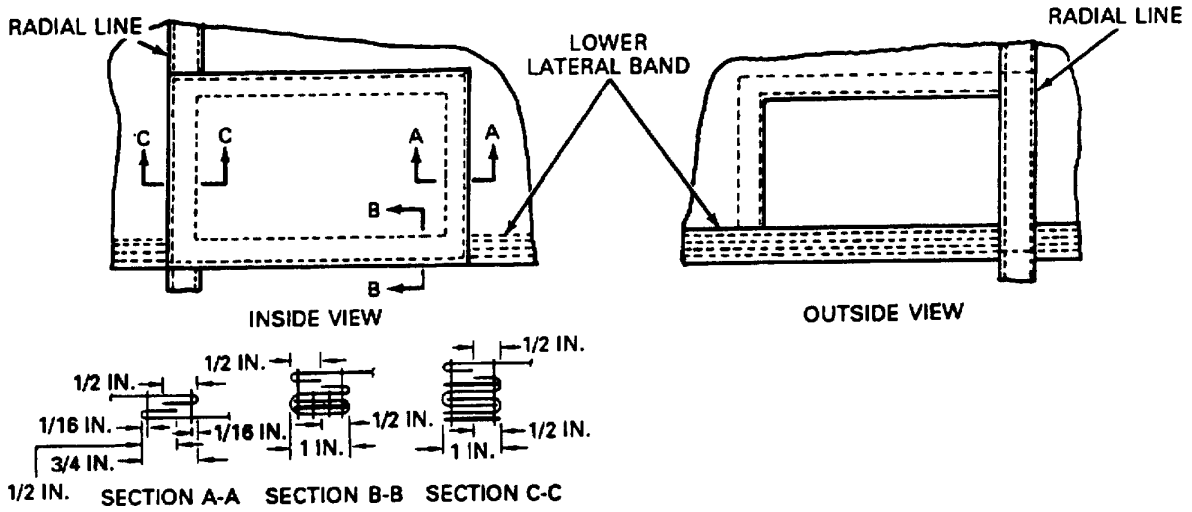

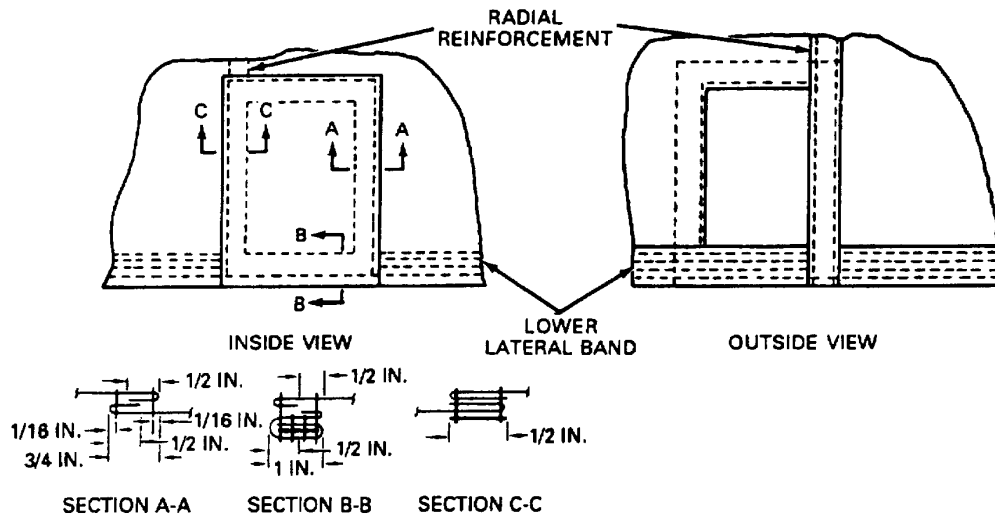
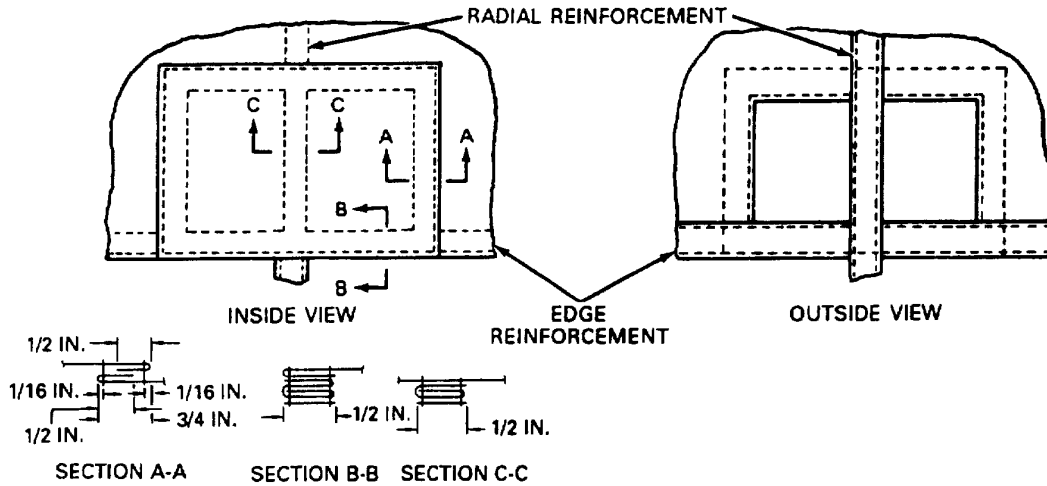

- Restenciling. As required, restencil identification markings using procedures in WP 0014 00, MARKING AND STENCILLING.

END OF WORK PACKAGE



---

**UNIT MAINTENANCE**  
**28-FOOT DIAMETER CARGO EXTRACTION PARACHUTE**  
**RADIAL TAPE**

---

**THIS TASK COVERS:**

- Repair
- 

**Tools**

Aid, Splicing (Item 1, WP 0056 00)  
 Knife (Item 5, WP 0056 00)  
 Knife, Hot Metal (Item 6, WP 0056 00)  
 Sewing Machine, Light-Duty (Item 21, WP 0056 00)  
 Sewing Machine, Zig-Zag (Item 23, WP 0056 00)  
 Shears (Item 24, WP 0056 00)  
 Yardstick (Item 26, WP 0056 00)

**Materials/Parts**

Thread, Nylon, Size E (Item 30/31, WP 0065 00)  
 Webbing, Nylon, Type IV, 1-IN., OD (Item 41, WP 0065 00)

**Personnel Required**

92R (10) Parachute Rigger

**Equipment Condition**

Cleaned (WP 0008 00).  
 Inspected (WP 0009 00).  
 Unpacked, laid flat.

**References**

WP 0012 00, WP 0013 00

---

**REPAIR**

1. Restitching. Restitch radial tape using a light-duty sewing machine and size E nylon thread of contrasting color. Stitch over original pattern, 7 to 11 stitches per inch. Lock each row of stitches two-inches at each end. When radial webbing stitching has failed and section separation from radial webbing has occurred at the leading or trailing edge of ring slots, the repair will be accomplished as follows:
  - a. Restitch failure in accordance with original construction. Sew a double throw zig-zag stitching across the width of radial webbing at leading/trailing edge of ring slot. Zig-zag stitching should be centered on width of reinforced hem of leading/trailing edge and will be stitched in accordance with WP 0012 00, STITCHING AND RESTITCHING RESPECIFICATIONS.
  - b. As an option, if a zig-zag sewing machine is not available, a box stitch pattern (double row stitching at box ends)  $1\frac{1}{4}$ -inches in length may be used. Box should start on reinforced hem of leading/trailing edge, approximately  $\frac{1}{8}$ -inches from edge of ring, and proceed in length along radial seam of ring.

---

**NOTE**

---

If any portion of a radial tape is damaged on the inside and the outside of the canopy, the splicing effort will be accomplished on both the inside and outside radial tape webbing. Radial webbing may be spliced one time provided the damaged area does not exceed 12-inches in length. Webbing splices may be applied to either or both sides of radial seam.

2. Splicing. Splice damaged radial tape as follows:
  - a. Place canopy on a repair table with damaged side of radial tape facing up and smooth out canopy material in affected area.
  - b. Cut a length 1-inch wide, type IV nylon tape, long enough to extend 12-inches beyond each side of damaged area and sear ends as specified in WP 0013 00, SEARING AND WAXING.

- c. Center tape length over damaged area. Using a light-duty sewing machine and size E nylon thread, secure splice by stitching 7 to 11 stitches per inch for full length of splice.

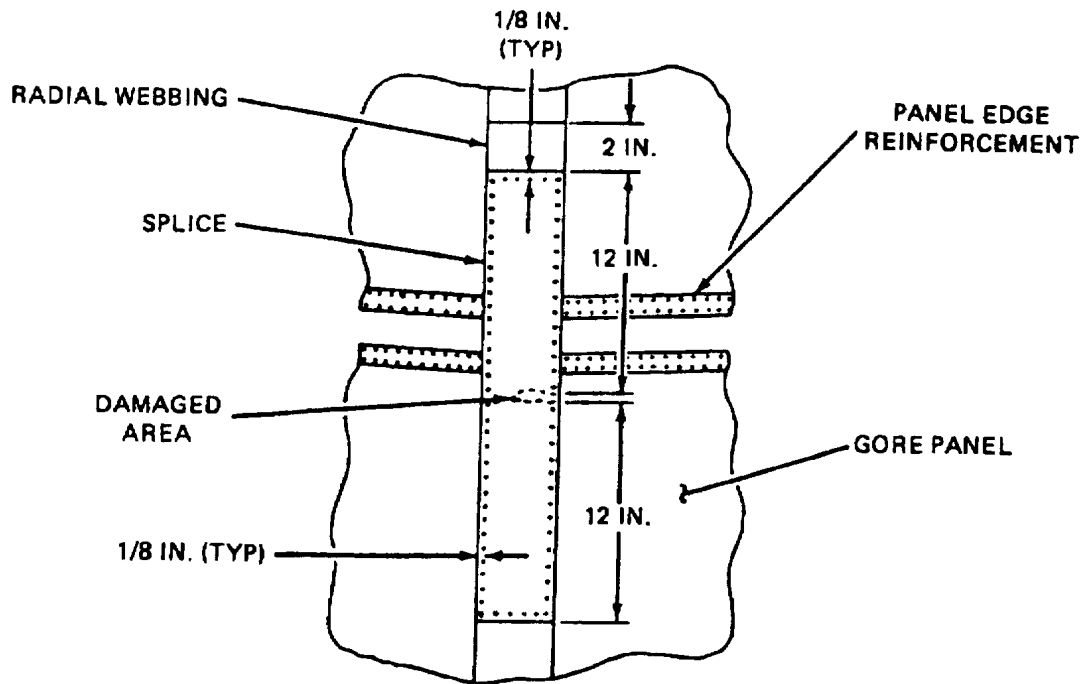

END OF WORK PACKAGE

---

**UNIT MAINTENANCE**  
**28-FOOT DIAMETER CARGO EXTRACTION PARACHUTE**  
**VERTICAL TAPE**

---

**THIS TASK COVERS:**

- Repair
- 

**Tools**

Aid, Splicing (Item 1, WP 0056 00)  
 Knife (Item 5, WP 0056 00)  
 Knife, Hot Metal (Item 6, WP 0056 00)  
 Sewing Machine, Light-Duty (Item 21, WP 0056 00)  
 Sewing Machine, Zig-Zag (Item 23, WP 0056 00)  
 Shears (Item 24, WP 0056 00)  
 Yardstick (Item 26, WP 0056 00)

**Materials/Parts**

Pushpins (Local Purchase)  
 Tape, Nylon, Type III, 1/2-IN., OD (Item 19, WP 0065 00)  
 Thread, Nylon, Size E (Item 30/31, WP 0065 00)

**Personnel Required**

92R (10) Parachute Rigger

**Equipment Condition**

Cleaned (WP 0008 00).  
 Inspected (WP 0009 00).  
 Unpacked, laid flat.

**References**

WP 0012 00, WP 0013 00

---

**REPAIR**

1. Restitching. Restitch vertical tape. Using a light-duty sewing machine and size E nylon thread of contrasting color, stitch over original pattern, 7 to 11 stitches per inch. Lock each row of stitches two-inches at each end. When vertical webbing stitching has failed and section separation from vertical webbing has occurred at the leading or trailing edge of ring slots, the repair will be accomplished as follows:
  - a. Restitch failure in accordance with original construction. Sew a double throw zig-zag stitching across the width of vertical webbing at leading/trailing edge of ring slot. Zig-zag stitching should be centered on width of reinforced hem of leading/trailing edge and will be stitched in accordance with WP 0012 00, SEWING PROCEDURES.
  - b. As an option, if a zig-zag sewing machine is not available, a box stitch pattern (double row stitching at box ends) 1<sup>1</sup>/<sub>4</sub>-inches in length may be used. Box should start on reinforced hem of leading/trailing edge, approximately 1<sup>1</sup>/<sub>8</sub>-inches from edge of ring, and proceed in length along radial seam of ring.
2. Splicing. Splice damaged vertical tape as follows:
  - a. Place canopy on a repair table with damaged side of vertical tape facing up and smooth out canopy material in affected area.

---

**NOTE**

---

The vertical tape may be spliced an unlimited number of times.

- b. Cut a length of 1/2-inch wide type III nylon tape, long enough to extend 6-inches beyond each side of damaged area and sear ends as specified in WP 0013 00, SEARING AND WAXING.

- c. Center webbing length over damaged area. Secure the splice with a box stitch,  $\frac{1}{16}$ -inch in from each edge. Using a light-duty sewing machine and size E thread, secure splice by stitching 7 to 11 stitches per inch for full length of splice.

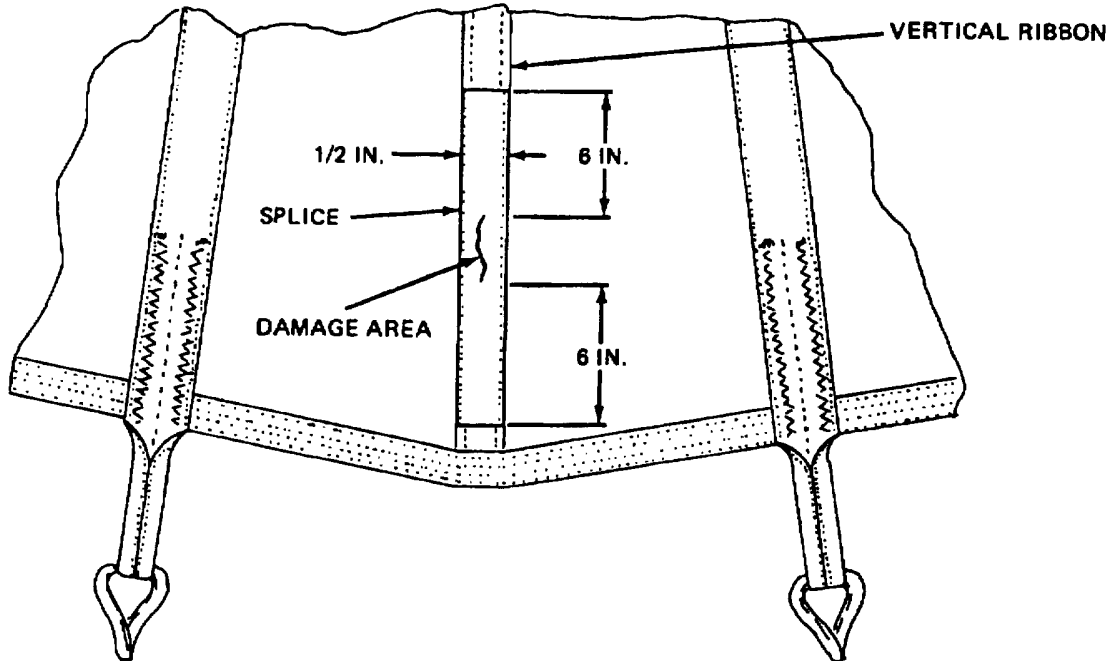

END OF WORK PACKAGE

**UNIT MAINTENANCE**  
**28-FOOT DIAMETER CARGO EXTRACTION PARACHUTE**  
**PANEL EDGE REINFORCEMENT**

**THIS TASK COVERS:**

- Repair

**Tools**

Aid, Splicing (Item 1, WP 0056 00)  
 Knife (Item 5, WP 0056 00)  
 Knife, Hot Metal (Item 6, WP 0056 00)  
 Sewing Machine, Light-Duty (Item 21, WP 0056 00)  
 Shears (Item 24, WP 0056 00)  
 Yardstick (Item 26, WP 0056 00)

**Personnel Required**

92R (10) Parachute Rigger

**Equipment Condition**

Cleaned (WP 0008 00).  
 Inspected (WP 0009 00).  
 Canopy laid flat on repair table.

**Materials/Parts**

Tape, Nylon, Type III, 1/2-IN., OD (Item 19, WP 0065 00)  
 Thread, Nylon, Size E (Item 30/31, WP 0065 00)

**References**

WP 0012 00 and WP 0013 00

**REPAIR**

1. Restitching. Restitching of upper lateral band is authorized. Use a light-duty sewing machine and size E nylon thread of contrasting color. Stitch over the original stitch pattern 7 to 11 stitches per inch. Lock each row of stitches two inches at each end. Stitch according to WP 0012 00 and Table 2, WP 0012 00, SEWING PROCEDURES.

**NOTE**

The panel edges may be spliced only once and will not be replaced.

2. Splicing. A panel edge reinforcement may be spliced one time as follows:
  - a. Cut a length of 1/2-inch wide, type III nylon webbing long enough to extend 6-inches beyond each side of damaged area and sear ends (WP 0013 00, SEARING AND WAXING).
  - b. Center webbing length over damaged area and secure splice by stitching a box stitch formation, 1/16-inch in from each edge, full length of splice material.

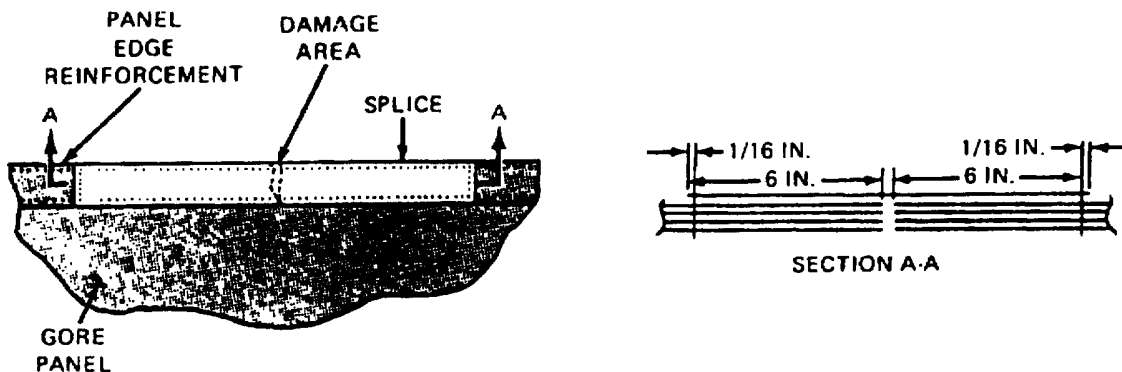

**END OF WORK PACKAGE**

**THIS PAGE INTENTIONALLY LEFT BLANK**

---

**UNIT MAINTENANCE**  
**28-FOOT DIAMETER CARGO EXTRACTION PARACHUTE**  
**SKIRT REINFORCEMENT (LOWER LATERAL BAND)**

---

**THIS TASK COVERS:**

- Repair
- 

**Tools**

Aid, Splicing (Item 1, WP 0056 00)  
Knife (Item 5, WP 0056 00)  
Knife, Hot Metal (Item 6, WP 0056 00)  
Sewing Machine, Heavy-Duty (Item 20, WP 0056 00)  
Sewing Machine, Light-Duty (Item 21, WP 0056 00)  
Sewing Machine, Zig-Zag (Item 23, WP 0056 00)  
Shears (Item 24, WP 0056 00)  
Yardstick (Item 26, WP 0056 00)

**Materials/Parts**

Thread, Nylon, Size E (Item 30/31, WP 0065 00)  
Webbing, Nylon, Tubular, 1-IN., OD (Item 39, WP 0065 00)

---

**Personnel Required**

92R (10) Parachute Rigger

**Equipment Condition**

Cleaned (WP 0008 00).  
Inspected (WP 0009 00).  
Unpacked, laid flat on repair table.

**References**

WP 0012 00

**REPAIR**

---

**NOTE**

---

The skirt reinforcement tape may have one splice between any suspension line(s) and cannot be replaced. If the damage is located in a previously spliced area between two suspension lines, the earlier made splice material will be removed before attempting a second splice repair.

1. Stitching and restitching. Stitch and restitch (WP 0012 00, SEWING PROCEDURES) with size E nylon thread that contrasts the color of the original stitching and material when possible. Lock all straight stitching by back stitching at least 2-inches. Zig-zag restitching should extend ¼-inch into undamaged stitching at each end. Restitch directly over the original stitching. Follow the original stitch pattern as closely as possible.
2. Splicing. A skirt reinforcement (lower lateral band) is limited to one splice, which will be made as follows:
  - a. Place the canopy on a repair table with the damaged area facing up.
  - b. Remove the pocket bands and suspension line attaching loops on each side of the damaged area by cutting the stitching securing each of the pocket bands and attaching loops to the canopy.
  - c. If the damage extends into a radial tape, remove the pocket band and suspension line attaching loop at the damaged tape, and also the pocket band and attaching loop on each side of the damaged area.

- d. To splice a skirt reinforcement (lower lateral band) damaged between two radial tapes, cut a length of 1-inch wide tubular nylon webbing long enough to extend 4-inches beyond the radial tapes on each side of the damaged area and sear the ends.

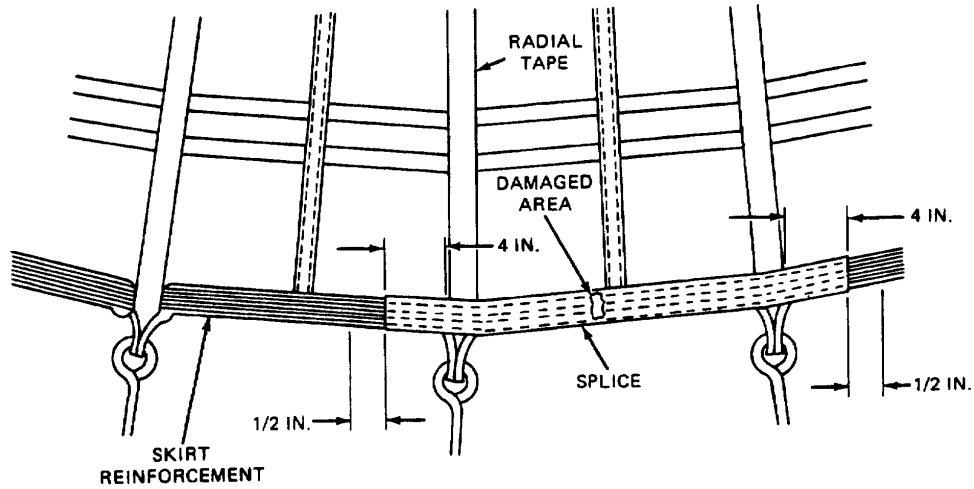

- e. If the damage extends into a radial tape, cut a length of 1-inch wide nylon tape long enough to extend 4-inches beyond the radial tapes located on each side of the damaged radial tape and sear the ends.

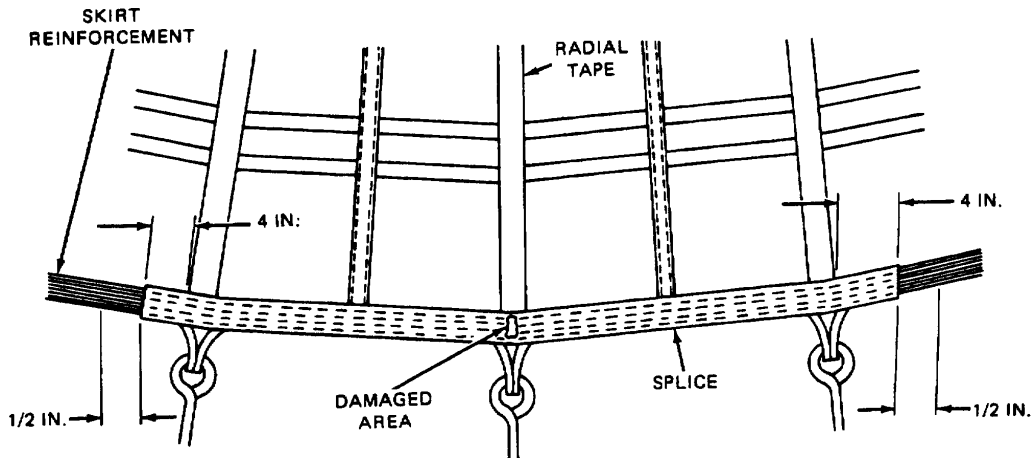

- f. Center the splice material over the damaged area and secure the splice by stitching four rows of stitching lengthwise along the full length of the splice. Overstitch each end of the splice material by 1/2-inch. Stitching will be made with a heavy-duty sewing machine and size 3, nylon thread, 5 to 8 stitches per inch.
- g. Reinstall the applicable pocket bands and suspension line attaching loops, refer to WP 0025 00 and WP 0026 00 for more details.

**END OF WORK PACKAGE**



**UNIT MAINTENANCE**  
**28-FOOT DIAMETER CARGO EXTRACTION PARACHUTE**  
**POCKET BAND**

**THIS TASK COVERS:**

- Repair
- Replace

**Tools**

- Knife (Item 5, WP 0056 00)
- Knife, Hot Metal (Item 6, WP 0056 00)
- Sewing Machine, Light-Duty (Item 21, WP 0056 00)
- Sewing Machine, Medium-Duty (Item 22, WP 0056 00)
- Sewing Machine, Zig-Zag (Item 23, WP 0056 00)
- Shears (Item 24, WP 0056 00)
- Yardstick (Item 26, WP 0056 00)

**Personnel Required**

92R (10) Parachute Rigger

**Equipment Condition**

Cleaned (WP 0008 00).  
 Inspected (WP 0009 00).  
 Unpacked, laid flat on repair table.

**Materials/Parts**

- Marker, Felt-Tip, Black (Item 13, WP 0065 00)
- Thread, Nylon, Size FF (Item 32/33, WP 0065 00)
- Webbing, Nylon, Type IV, 1-IN., OD (Item 41, WP 0065 00)

**References**

WP 0012 00, WP 0013 00

**REPAIR**

Stitch and restitch (WP 0012 00, SEWING PROCEDURES) with size FF nylon thread that matches the color of the original stitching, when possible. Lock all zig-zag stitching by over stitching at least 1/2-inch. Restitch directly over the original stitch pattern; follow the original stitch pattern as closely as possible.

**REPAIR**

Replace an unserviceable pocket band by fabricating a new one as follows:

1. Using a marking aid, mark canopy at each end of original pocket band.
2. Cut stitching on both ends of the original pocket band and remove pocket band from canopy skirt.
3. Cut a  $7\frac{5}{16}$ -inch length of 1-inch wide nylon webbing type IV, sear ends (WP 0013 00, SEARING AND WAXING).
4. Position tape length in original pocket band location.
5. Using a medium-duty sewing machine and size FF nylon thread, secure each end of replacement pocket band with a 2-inch long, 1/4-inch wide row of stitching. Stitching will be 7 to 11 stitches per inch.

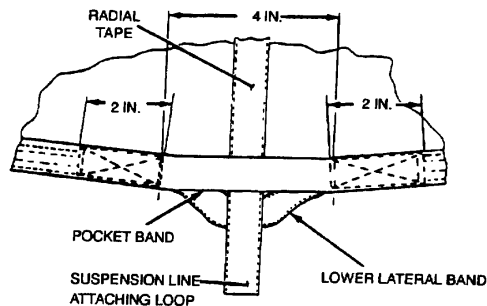

**END OF WORK PACKAGE**

**THIS PAGE INTENTIONALLY LEFT BLANK**

---

**UNIT MAINTENANCE**  
**28-FOOT DIAMETER CARGO EXTRACTION PARACHUTE**  
**SUSPENSION LINE ATTACHMENT LOOP**

---

**THIS TASK COVERS:**

- Repair
  - Replace
- 

**Tools**

Knife (Item 5, WP 0056 00)  
 Knife, Hot Metal (Item 6, WP 0056 00)  
 Sewing Machine, Medium-Duty (Item 21, WP 0056 00)  
 Sewing Machine, Zig-Zag (Item 23, WP 0056 00)  
 Shears (Item 24, WP 0056 00)  
 Yardstick (Item 26, WP 0056 00)

**Materials/Parts**

Marker, Felt Tip, Black (Item 13, WP 0065 00)  
 Thread, Nylon, Size FF (Item 32/33, WP 0065 00)  
 Thread, Nylon, Size 3 (Item 24/25, WP 0065 00)  
 Webbing, Nylon, Type IV, 1-IN., OD (Item 41, WP 0065 00)

**Personnel Required**

92R (10) Parachute Rigger

**Equipment Condition**

Cleaned (WP 0008 00).  
 Inspected (WP 0009 00).  
 Unpacked, laid flat on repair table.

**References**

WP 0012 00, WP 0013 00

---



---

**NOTE**

---

Two methods of stitching are used when repairing and replacing the suspension line attachment loop. The stitching used when performing these functions will match those used in the original construction of the parachute.

**REPAIR**

Stitch and restitch (WP 0012 00, SEWING PROCEDURES) with size 3 nylon thread that matches the color of the original stitching, when possible, if the suspension line attachment loop is sewn with a 3-point WW stitch formation. Stitch and restitch with size FF nylon thread that matches the color of the original stitching, when possible, if the suspension line attachment loop is sewn with zig-zag stitch formation. Lock all zig-zag stitching by over stitching at least ½-inch. Restitch directly over the original stitch pattern, following the original stitch pattern as closely as possible.

**REPLACE**

Replace an unserviceable suspension line attachment loop by fabricating as follows:

1. Remove the original suspension line attachment loop by cutting the stitching that secures the loop at the canopy skirt.
2. Cut a 27-inch length of type IV nylon webbing and sear the ends (WP 0013 00, SEARING AND WAXING).
3. Using a marking aid, mark the webbing at  $3\frac{3}{4}$ ,  $8\frac{3}{4}$ ,  $13\frac{1}{4}$ ,  $17\frac{3}{4}$ ,  $22\frac{3}{4}$ , and  $26\frac{3}{4}$  inches from one end. Fold the webbing at the  $13\frac{1}{4}$  mark. This allows one end to extend ½-inch beyond the other.
4. Between the two marks that are 5-inches apart, fold the edges of the webbing toward the center of the webbing.

5. Stitch the folded webbing with size E nylon thread, 7 to 11 stitches per inch.

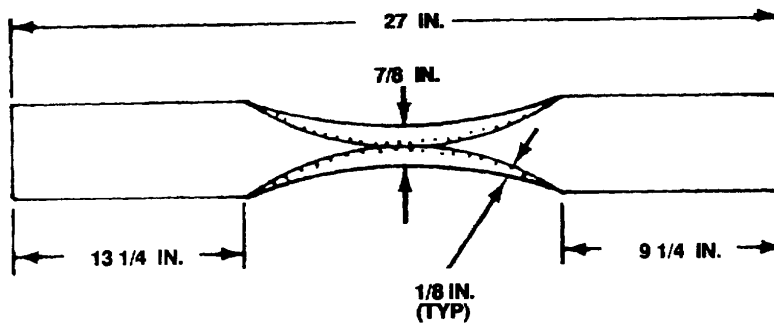

6. Tack one end of the replacing suspension line attaching loop to the unserviceable attaching loop that is routed through the end of the suspension line.
7. Position the suspension line attaching loop on the radial seam with the 4 1/2-inch end to the inside of the canopy. Fold the free end under 1/4-inch and position the 3 3/4-inch end to the outside of the canopy.

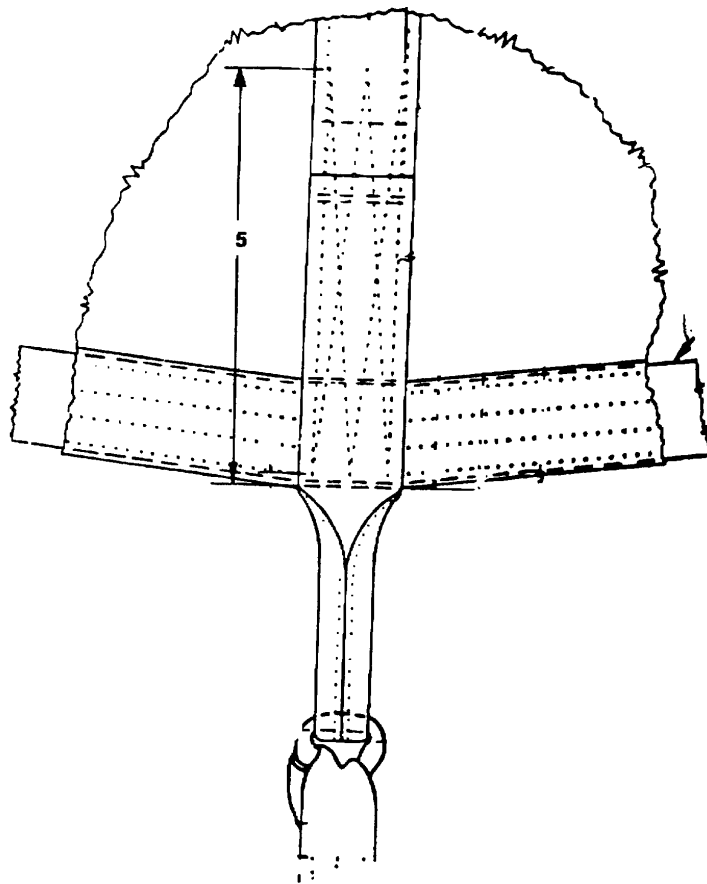

8. Secure the suspension line attaching loop to the radial seam with the stitch formation that matches the original construction. If a 3-point WW stitch formation is being used, stitch with size 3 nylon thread. If zig-zag stitching is being used, stitch with size FF nylon thread.

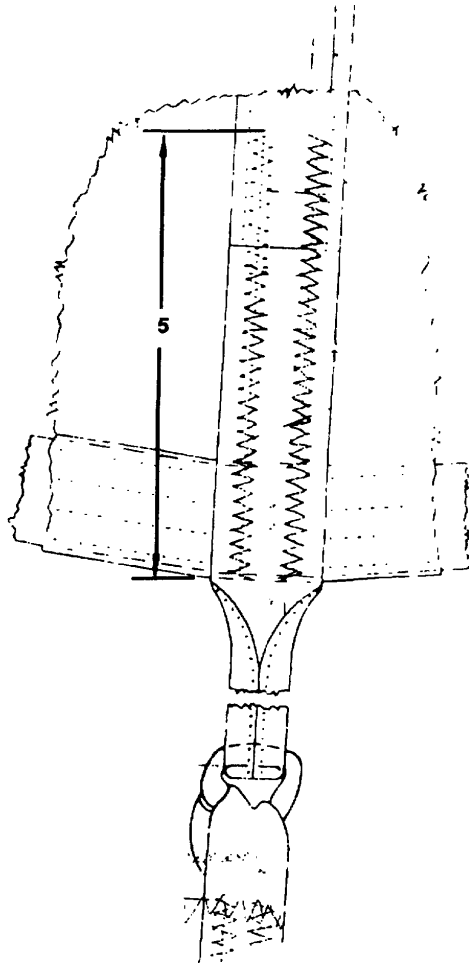

**END OF WORK PACKAGE**

**THIS PAGE INTENTIONALLY LEFT BLANK**

---

**UNIT MAINTENANCE**  
**28-FOOT DIAMETER CARGO EXTRACTION PARACHUTE**  
**SUSPENSION LINE**

---

**THIS TASK COVERS:**

- Repair
- 

**Tools**

Aid, Splicing (Item 1, WP 0056 00)  
Knife (Item 5, WP 0056 00)  
Sewing Machine, Medium-Duty (Item 22, WP 0056 00)  
Sewing Machine, Zig-Zag (Item 23, WP 0056 00)  
Yardstick (Item 26, WP 0056 00)

**Materials/Parts**

Marker, Felt-Tip, Black (Item 13, WP 0065 00)  
Thread, Nylon, Size FF (Item 32/33, WP 0065 00)  
Webbing, Nylon, Tubular, 3/4-IN. (Item 38, WP 0065 00)

---

**Personnel Required**

92R (10) Parachute Rigger

**Equipment Condition**

Cleaned (WP 0008 00).  
Inspected (WP 0009 00).  
Unpacked, laid flat on repair table.

**REPAIR**

Stitch and restitch with thread, nylon that is contrasting in color to the fabric being stitched or the original thread being restitched. If contrasting color thread is not available, thread of matching color may be used, provided that all other specifications are met. Straight stitching and restitching should be locked by at least two-inches at each end of a stitch row when possible. Zig-zag restitching should extend at least 1/4-inch into undamaged stitching at each end, when possible. Restitch directly over the original stitching and follow the original stitch pattern as close as possible.

**END OF WORK PACKAGE**

**THIS PAGE INTENTIONALLY LEFT BLANK**



---

**UNIT MAINTENANCE**  
**28-FOOT DIAMETER CARGO EXTRACTION PARACHUTE**  
**CONNECTOR LINK**

---

**THIS TASK COVERS:**

- Repair
  - Replace
- 

**Tools**

File, Flat (Item 4, WP 0056 00)  
 Mallet, Rawhide (Item 9, WP 0056 00)  
 Screwdriver, Flat-Tip (Item 15, WP 0056 00)  
 Separator, Link (Item 17, WP 0056 00)

**Personnel Required**

92R (10) Parachute Rigger

**Equipment Condition**

Connector link laid out on table.

---

**Materials/Parts**

Cloth, Abrasive (Item 3, WP 0065 00)

---



---

**NOTE**

---

The 28-foot diameter extraction parachute uses large connector links.

**REPAIR**

Repair connector link assembly as follows:

1. Cleaning. Remove burrs, rough spots, rust, or corrosion from a parachute connector link assembly by either filing with a metal file or buffing with abrasive cloth.
2. Replacing a locking screw. Replace a damaged or missing locking screw on a parachute connector link with a serviceable item from stock.

**REPLACE**

A parachute connector link assembly that is damaged beyond repair will be replaced with a serviceable parachute connector link assembly from stock. Use the following procedures.

1. Using a flat-tip (slotted-head) screwdriver, remove two locking screws from ends of a replacement parachute connector link assembly and disassemble link.

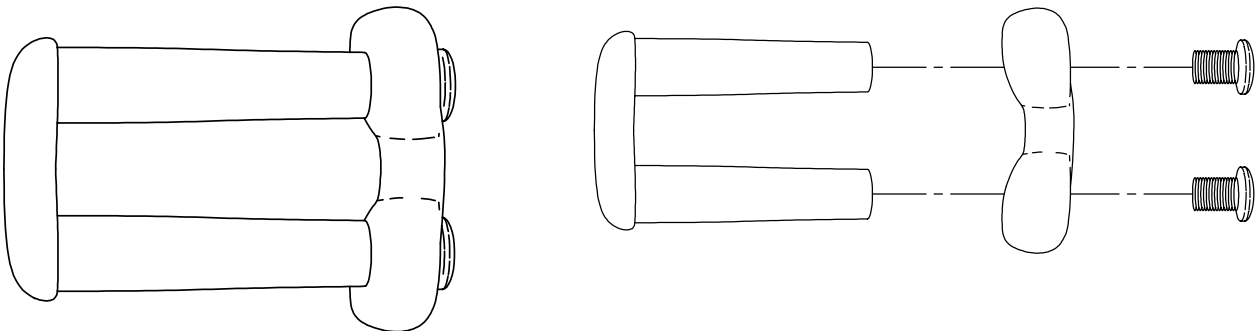

2. Using a flat-tip (slotted-head) screwdriver, remove two locking screws from damaged original parachute connector link assembly. Disassemble link assembly, using a link separator, as required. If connector link contains suspension lines, ensure lines are not allowed to slide off damaged link during disassembly process.
3. As applicable, position a replacement link assembly adjacent to disassembled original link assembly and slide suspension lines from damaged link onto replacement link.
4. If required, pass remaining replacement link through attaching loop of adjoining component.
5. Fit replacement link together and ensure legs are engaged by tapping end of each bar with a mallet.
6. As applicable, trace suspension lines from connector link assembly to canopy to ensure lines are properly installed and in correct sequence.

**END OF WORK PACKAGE**

---

**UNIT MAINTENANCE**  
**28-FOOT DIAMETER CARGO EXTRACTION PARACHUTE**  
**ADAPTER WEB**

---

**THIS TASK COVERS:**

- Inspect
  - Service
  - Repair
  - Replace
- 

**Personnel Required**

92R (10) Parachute Rigger

**References**

WP 0006 00, WP 0008 00, WP 0009 00

**Equipment Condition**Cleaned (WP 0008 00).  
Inspected (WP 0009 00).  
Laid out on table.

---

**INSPECT**

Inspect adapter web in accordance with WP 0006 00, PMCS, and WP 0009 00, INSPECTION.

**SERVICE**

Service adapter web by cleaning in accordance with WP 0008 00, CLEANING AND DRYING.

---

**CAUTION**

---

When performing a repair on the 9-foot long adapter web which requires the cutting of stitching or tacking, ensure that adjacent webbing material is not damaged during the cutting process.

**REPAIR**

Refer to individual component procedures for repair of adapter web.

**REPLACE**

Replace an unserviceable/unrepairable adapter web with a serviceable one from stock.

**END OF WORK PACKAGE**

**THIS PAGE INTENTIONALLY LEFT BLANK**

---

**UNIT MAINTENANCE**  
**28-FOOT DIAMETER CARGO EXTRACTION PARACHUTE**  
**ADAPTER WEB BODY**

---

**THIS TASK COVERS:**

- Repair
- 

**Tools**

Sewing Machine, Heavy-Duty (Item 20, WP 0056 00)

**Materials/Parts**

Thread, Nylon, Size 6 (Item 28/29, WP 0065 00)

**Personnel Required**

92R (10) Parachute Rigger

**Equipment Condition**

Cleaned (WP 0008 00).  
Inspected (WP 0009 00).  
Laid out on table.

**References**

WP 0014 00

---

**REPAIR**

1. Stitching. Stitch and restitch with size 6 nylon thread that matches the color of the original stitching, when possible. Lock all straight stitching by backstitching at least 1/2-inch. Restitch by overstitching each end of the stitch formation by 1/2-inch. Restitch directly over the original stitching, following the original stitch pattern as closely as possible. Stitch 5 to 8 stitches per inch, using a heavy-duty sewing machine.
2. Restencil. As required, restencil identification marks using procedures, tools, and materials and parts identified in WP 0014 00, MARKING AND RESTENCILLING.

**END OF WORK PACKAGE**

**THIS PAGE INTENTIONALLY LEFT BLANK**

**UNIT MAINTENANCE**  
**28-FOOT DIAMETER CARGO EXTRACTION PARACHUTE**  
**ADAPTER WEB LONG BUFFER**

**THIS TASK COVERS:**

- Repair
- Replace

**Tools**

Pot, Melting, Electric (Item 13, WP 0056 00)  
 Knife (Item 5, WP 0056 00)  
 Needle, Tacking (Item 10, WP 0056 00)  
 Shears (Item 24, WP 0056 00)  
 Yardstick (Item 26, WP 0056 00)

**Equipment Condition**

Cleaned (WP 0008 00).  
 Inspected (WP 0009 00).  
 Laid out on work table.

**Personnel Required**

92R (10) Parachute Rigger

**Materials/Parts**

Beeswax, Technical (Item 2, WP 0065 00)  
 Tape, Lacing and Tying (Item 18, WP 0065 00)  
 Thread, Cotton, Ticket 8/7, Natural (Item 23, WP 0065 00)  
 Wax, Paraffin, Technical (Item 34, WP 0065 00)  
 Webbing, Cotton, Type X, OD (Item 37, WP 0065 00)

**REPAIR**

Replace broken or loose tacking securing the short buffer in the 5-inch long single attaching loop by retacking according to original tacking details; use one turn single, tape, lacing and tying at each tacking point. Secure the tacking with a square knot and locking knot; trim ends to 1/2-inch.

**REPLACE**

Replace a damaged or missing long buffer in a 6 1/8-inch long single attaching loop by fabricating as follows:

1. If applicable, remove the original long butter by cutting the tacking securing the buffer within the large attaching loop.
2. Cut a 10-inch length of 1 3/4-inch wide, type X cotton webbing and wax the ends.
3. Double the webbing length and position the buffer in the original buffer location, within the large single attaching loop.
4. Secure the buffer to the loop webbing by handtacking at three points using one turn single, tape, lacing and tying at each point according to original construction details. Secure the ends of each tacking with a square knot and trim tacking ends to 1/2-inch.

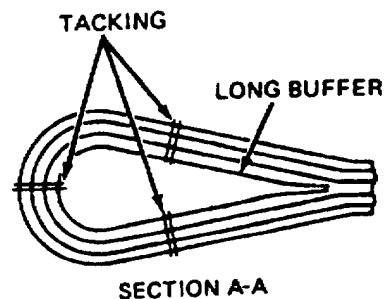
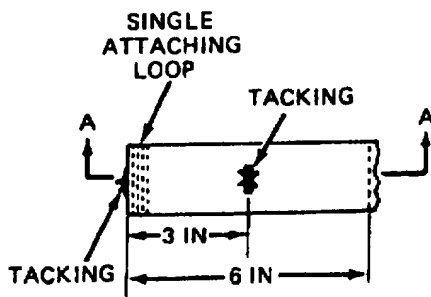

**END OF WORK PACKAGE**

**THIS PAGE INTENTIONALLY LEFT BLANK**



---

**UNIT MAINTENANCE**  
**28-FOOT DIAMETER CARGO EXTRACTION PARACHUTE**  
**ADAPTER WEB SHORT BUFFER**

---

**THIS TASK COVERS:**

- Repair
  - Replace
- 

**Tools**

Knife (Item 5, WP 0056 00)  
Pot, Melting, Electric (Item 13, WP 0056 00)  
Sewing Machine, Heavy-Duty (Item 20, WP 0056 00)  
Shears (Item 24, WP 0056 00)

**Materials/Parts**

Beeswax, Technical (Item 2, WP 0065 00)  
Thread, Nylon, Size 6 (Item 28/29, WP 0065 00)  
Wax, Paraffin, Technical (Item 34, WP 0065 00)  
Webbing, Cotton, Type VIII, 1<sup>3</sup>/<sub>4</sub>-IN. (Item 36, WP 0065 00)

**Equipment Condition**

Cleaned (WP 0008 00).  
Inspected (WP 0009 00).  
Laid out on work table.

**References**

WP 0012 00

**Personnel Required**

92R (10) Parachute Rigger

---

**REPAIR**

Stitch and restitch with size 6 nylon thread, that matches the color of the original stitching, when possible. Lock all straight stitching by backstitching at least 1/2-inch. Restitch by overstitching each end of the stitch formation by 1/2-inch. Restitch directly over the original stitching; follow the original stitch pattern as closely as possible. Stitch according to WP 0012 00 and Table 2, WP 0012 00, SEWING PROCEDURES.

**REPLACE**

Replace a damaged short buffer by fabricating as follows:

1. Remove an original buffer from a small attaching loop by cutting the stitching securing the buffer within the loop.
2. Cut a 6-inch length of 1<sup>3</sup>/<sub>4</sub>-inch wide, type VIII cotton webbing and wax the ends.
3. Double the webbing length and allow one end to overlap the opposite end by 1/2-inch.
4. Place the doubled webbing length in the original attaching loop according to original installation details. Secure the buffer in the loop by stitching according to original construction details, using a heavy-duty sewing machine, 4 to 6 stitches per inch with size 6 nylon thread.

**END OF WORK PACKAGE**

**THIS PAGE INTENTIONALLY LEFT BLANK**

---

**UNIT MAINTENANCE**  
**28-FOOT DIAMETER CARGO EXTRACTION PARACHUTE**  
**ADAPTER WEB FIXED KEEPER**

---

**THIS TASK COVERS:**

- Repair
  - Replace
- 

**Tools**

Knife (Item 5, WP 0056 00)  
Sewing Machine, Heavy-Duty (Item 20, WP 0056 00)  
Shears (Item 24, WP 0056 00)

**Equipment Condition**

Cleaned (WP 0008 00).  
Inspected (WP 0009 00).  
Laid out on work table.

**Materials/Parts**

Tape, Pressure-Sensitive, Type III, 1-IN. (Item 21, WP 0065 00)  
Thread, Nylon, Size 6 (Item 28/29, WP 0065 00)

**References**

WP 0012 00

**Personnel Required**

92R (10) Parachute Rigger

---

**REPAIR**

Stitch and restitch with size 6 nylon thread, that matches the color of the original stitching, when possible. Lock all straight stitching by backstitching at least ½-inch. Restitch by overstitching each end of the stitch formation by ½-inch. Restitch directly over the original stitching; follow the original stitch pattern as closely as possible. Stitch according to WP 0012 00 and Table 2, WP 0012 00, SEWING PROCEDURES.

**REPLACE**

Replace a damaged fixed webbing keeper by fabricating as follows:

1. Remove an unserviceable fixed webbing keeper by cutting the stitching that secures the keeper to the adapter web.
2. Restitch the original fixed keeper area on the adapter web according to original construction details, using a heavy-duty sewing machine, 4 to 6 stitches per inch, and size 6 nylon thread.
3. Cut a length of 1-inch wide type III filament-reinforced pressure-sensitive tape long enough to make three turns around the adapter web.
4. Wrap the tape length tight around the adapter web in the original fixed keeper location.

**END OF WORK PACKAGE**

**THIS PAGE INTENTIONALLY LEFT BLANK**

---

**UNIT MAINTENANCE**  
**28-FOOT DIAMETER CARGO EXTRACTION PARACHUTE**  
**DEPLOYMENT BAG**

---

**THIS TASK COVERS:**

- Inspect
  - Service
  - Repair
  - Replace
- 

**Personnel Required**

92R (10) Parachute Rigger

**References**WP 0006 00, WP 0008 00,  
WP 0009 00**Equipment Condition**Cleaned (WP 0008 00).  
Inspected (WP 0009 00).  
Laid out on work table.

---

**INSPECT**

Refer to WP 0006 00, PMCS, and WP 0009 00, INSPECTION, for inspection procedures.

**SERVICE**

Refer to WP 0008 00 for cleaning procedures.

**REPAIR**

Refer to individual repair procedures.

---

**CAUTION**

---

When performing a repair on a 28-foot diameter extraction parachute deployment bag that requires the cutting of stitching or an original part, ensure that adjacent bag material is not damaged during the cutting process.

**REPLACE**

An unreparable deployment bag will be replaced with a serviceable bag from stock.

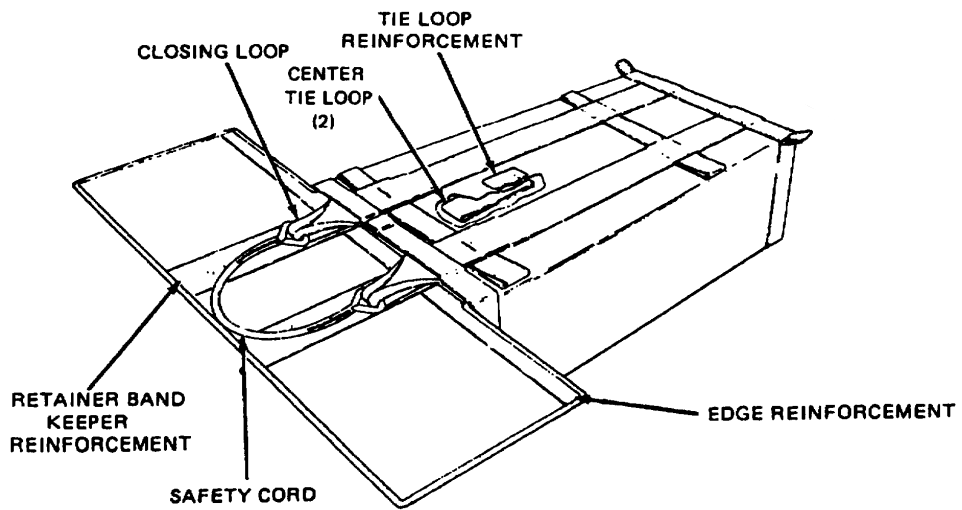
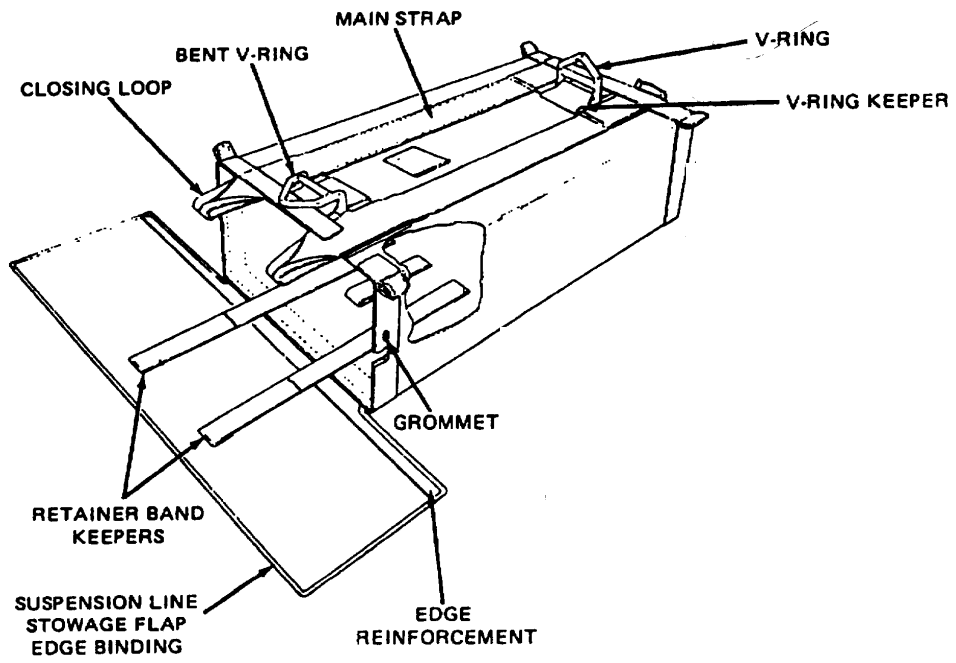

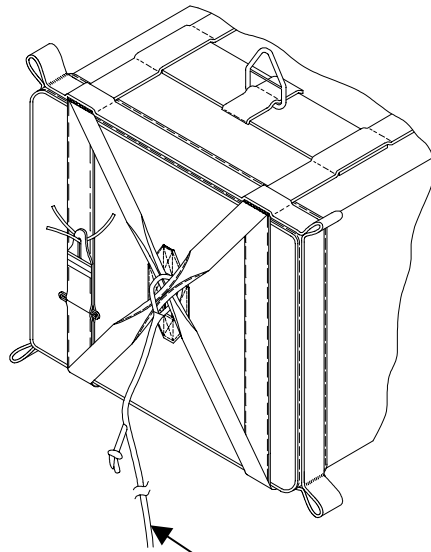

Pendulum Line

END OF WORK PACKAGE

**THIS PAGE INTENTIONALLY LEFT BLANK**



**UNIT MAINTENANCE**  
**28-FOOT DIAMETER CARGO EXTRACTION PARACHUTE**  
**GROMMET**

**THIS TASK COVERS:**

- Repair
- Replace

**Tools**

File, Flat (Item 4, WP 0056 00)  
 Mallet, Rawhide (Item 9, WP 0056 00)  
 Pliers, Lineman (Item 12, WP 0056 00)  
 Set, Chuck and Die (Item 18, WP 0056 00)  
 Sewing Machine, Medium-Duty (Item 20, WP 0056 00)

**Materials/Parts**

Cloth, Abrasive (Item 3, WP 0065 00)  
 Thread, Nylon, Size E (Item 30/31, WP 0065 00)

**References**

WP 0012 00

**Personnel Required**

92R (10) Parachute Rigger

**Equipment Condition**

Cleaned (WP 0008 00).  
 Inspected (WP 0009 00).

**REPAIR**

Repair grommet as follows:

1. Remove burrs, rough spots, rust, or corrosion from an insulated grommet by filing with a file or by buffing with an abrasive cloth.
2. Reset a loose grommet using the procedures listed below.
3. If fabric area around original grommet has been damaged, repair area by darning using procedures in WP 0012 00, SEWING PROCEDURES. If darning does not provide an adequate repair, construct a 2<sup>3</sup>/<sub>4</sub> by 2<sup>3</sup>/<sub>4</sub>-inch sized reinforcement cloth and fold under 1/2-inch on all sides. After removing original grommet (REPLACE procedure, step 1) sew cloth to inside with size E nylon thread, 7 to 11 stitches per inch, one row of stitches 1/8-inch from outside edge and the second row 3/8-inch from outside edge.

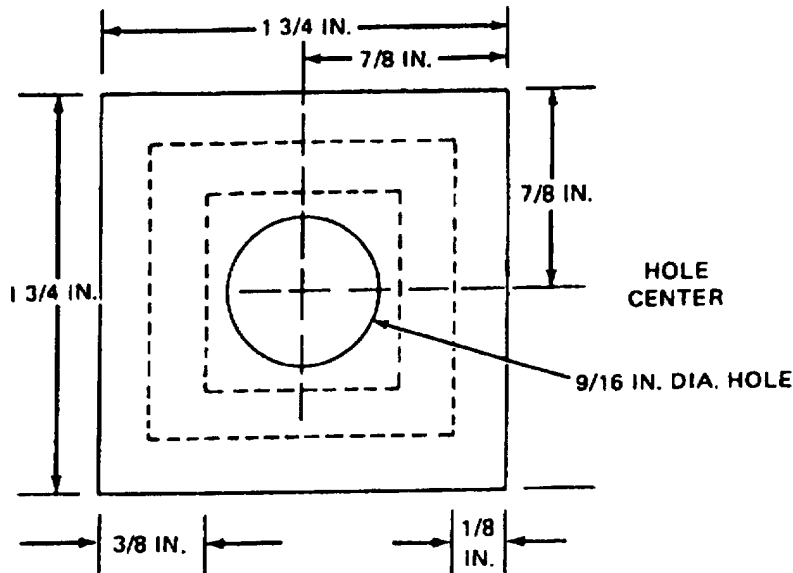

**REPLACE**

1. Remove original grommet as follows:
  - a. Using a suitable type tool, lift edge of original washer at one point.
  - b. Grip lifted washer edge with diagonal cutters and roll washer edge back to lift washer from original grommet. Remove original grommet from material.
2. Grommet installation by hand-held method.

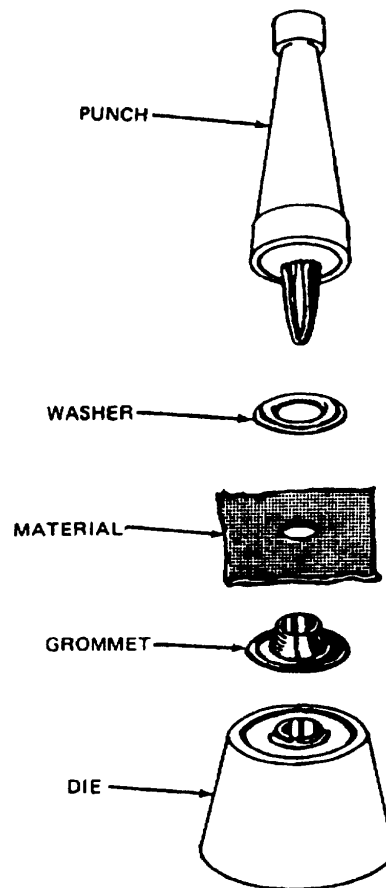

- a. Insert barrel of replacement grommet through accommodating hole in material and ensure grommet flange is located on same side of material as original grommet.
- b. Position grommet on die with barrel facing up and place the washer over grommet barrel.

**NOTE**

When installing a flat grommet by the hand-held method, ensure the grommet barrel and washer are aligned to preclude off-center setting of the grommet.

- c. Using a punch and a rawhide mallet or other non-steel impact device, spread grommet barrel by hammering until barrel collar is rolled down smooth on washer. If grommet barrel splits during hammering process, remove and replace installed grommet with a serviceable item from stock, repeating procedures in paragraph 2., steps a. and b., above.
  - d. Check seating of grommet. If grommet can be turned by hand, repeat paragraph 2., c. until grommet is firmly seated.
3. Grommet installation by hand-operated press.
- a. Install 1/4-inch chuck and die in hand-operated press, secure locking screws with hex wrench.

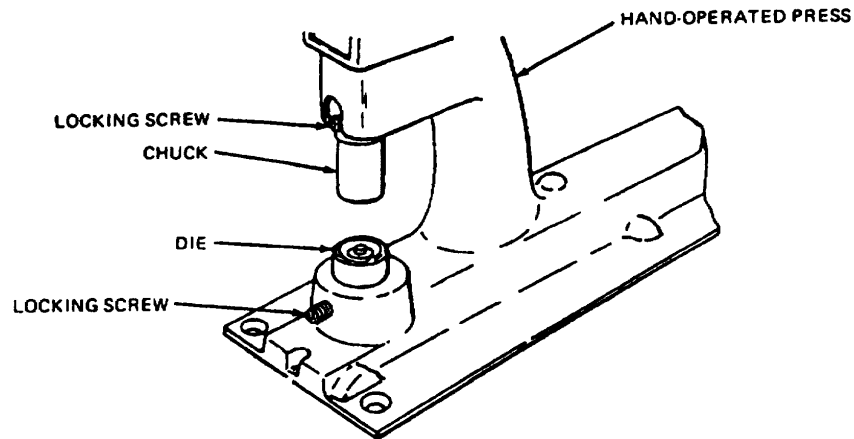

- b. Insert barrel of replacement grommet through hole in material. Ensure grommet flange is on same side of material as original grommet.

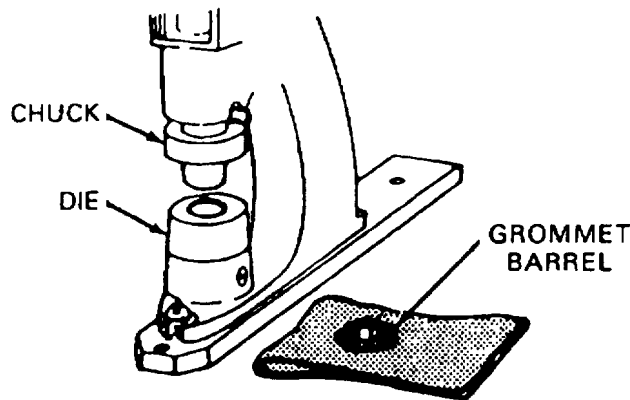

GROMMET BARREL INSERTED IN MATERIAL HOLE

- c. Position grommet on die in press, with barrel facing up, place replacement washer over barrel.

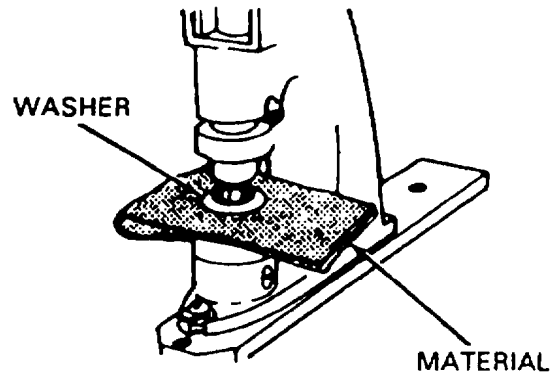

WASHER PLACED OVER GROMMET BARREL

- d. Depress handle or foot pedal, spreading grommet barrel until collar is rolled down smooth on washer.

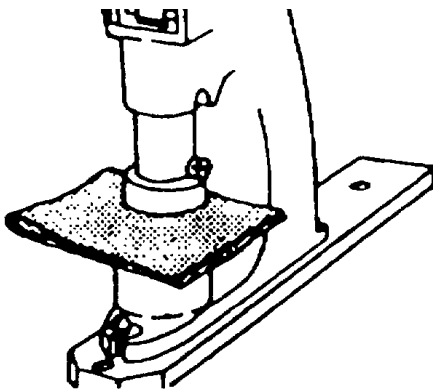

PRESS ACTIVATED TO SEAT THE GROMMET

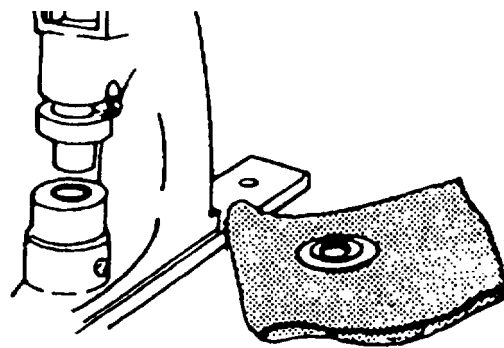

GROMMET INSTALLATION COMPLETED

- e. Check grommet for firm seating. If grommet can be turned by hand, repeat step d. above, until a firm seat is achieved.

END OF WORK PACKAGE

**UNIT MAINTENANCE**  
**28-FOOT DIAMETER CARGO EXTRACTION PARACHUTE**  
**DEPLOYMENT BAG RETAINER BAND KEEPER**

**THIS TASK COVERS:**

- Repair
- Replace

**Tools**

- Knife (Item 5, WP 0056 00)
- Knife, Hot Metal (Item 6, WP 0056 00)
- Sewing Machine, Medium-Duty (Item 22, WP 0056 00)
- Shears (Item 24, WP 0056 00)
- Yardstick (Item 26, WP 0056 00)

**Materials/Parts**

- Thread, Nylon, Size FF (Item 32/33, WP 0065 00)
- Webbing, Nylon, Type IV, 1-IN., OD (Item 41, WP 0065 00)

**References**

WP 0012 00

**Personnel Required**

92R (10) Parachute Rigger

**Equipment Condition**

- Cleaned (WP 0008 00).
- Inspected (WP 0009 00).
- Laid out on work table.

**REPAIR**

Stitch and restitch with size FF, nylon thread that matches the color of the original stitching, when possible. Lock all straight stitching by backstitching at least 1/2-inch. Restitch by overstitching each end of the stitch formation by 1/2-inch. Restitch directly over the original stitching, following the original stitch pattern as closely as possible. Stitching will be in accordance with WP 0012 00 and Table 2, WP 0012 00, SEWING PROCEDURES.

**REPLACE**

Replace a damaged retainer band keeper by fabricating as follows:

1. Remove the original retainer band keeper by cutting the stitching securing the keeper to the suspension line stowage flap and the inside of the bag bottom panel.
2. Cut a 30<sup>5</sup>/<sub>8</sub>-inch length of 1-inch wide, type IV nylon webbing and sear the ends.
3. Make a 1-inch long turnunder on one end of the webbing length and position the webbing in the original keeper location with the turnunder facing down on the suspension line stowage flap.
4. Secure each end of the webbing length to the deployment bag by stitching a 3/4-inch long single-X box-stitch formation with one double end.

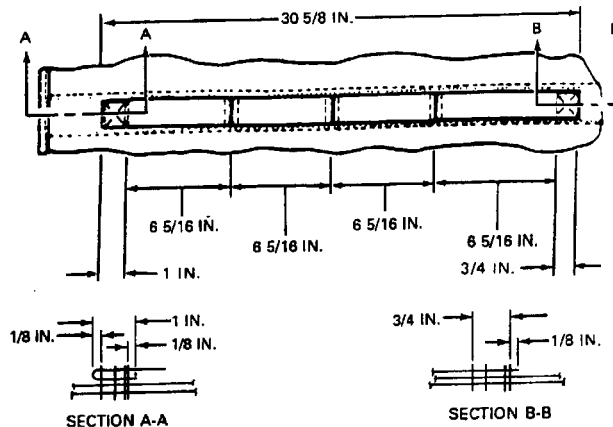

5. Make three lateral rows of stitching across the webbing width to form four equal-sided loops in the webbing length. Stitching will be made with a medium-duty sewing machine, 5 to 8 stitches per inch and size FF nylon thread.

**END OF WORK PACKAGE**

---

**UNIT MAINTENANCE**  
**28-FOOT DIAMETER CARGO EXTRACTION PARACHUTE**  
**DEPLOYMENT BAG RETAINER BAND KEEPER REINFORCEMENT**

---

**THIS TASK COVERS:**

- Repair
  - Replace
- 

**Tools**

Knife (Item 5, WP 0056 00)  
 Knife, Hot Metal (Item 6, WP 0056 00)  
 Sewing Machine, Medium-Duty (Item 22, WP 0056 00)  
 Shears (Item 24, WP 0056 00)  
 Yardstick (Item 26, WP 0056 00)

**Materials/Parts**

Thread, Nylon, Size FF (Item 32/33, WP 0065 00)  
 Webbing, Nylon, Type VIII, 1<sup>23</sup>/<sub>32</sub>-IN. (Item 42, WP 0065 00)

**References**

WP 0012 00, WP 0013 00

**Personnel Required**

92R (10) Parachute Rigger

**Equipment Condition**

Cleaned (WP 0008 00).  
 Inspected (WP 0009 00).  
 Laid out on work table.

---

**REPAIR**

Stitch and restitch with size FF thread, which matches the color of the original stitching, when possible. Lock all straight stitching by backstitching at least ½-inch. Restitch by overstitching each end of the stitch formation by ½-inch. Restitch directly over the original stitching, following the original stitch pattern as closely as possible. Stitch according to WP 0012 00 and Table 2, WP 0012 00, SEWING PROCEDURES.

**REPLACE**

Replace a damaged retainer band keeper reinforcement by fabricating as follows:

1. Remove portion of retainer band keeper that is secured to inside of suspension line stowage flap by cutting applicable stitching.
2. Turn flap to locate flap outside facing up and cut stitching securing edge binding tape over end of applicable damaged reinforcement. Cut stitching to a point 2 inches beyond each edge of reinforcement.
3. Cut a 22<sup>1</sup>/<sub>8</sub>-inch length of 1<sup>23</sup>/<sub>32</sub>-inch wide, type VIII nylon webbing and sear ends in accordance with WP 0013 00, SEARING AND WAXING.
4. Position webbing length over damaged reinforcement outside of suspension line stowage flap, ensure one webbing end is aligned with original reinforcement end at outer edge of suspension line stowage panel.
5. Fold loose edge binding back and secure webbing length over original reinforcement by stitching a box-stitch formation, <sup>1</sup>/<sub>8</sub>-inch in from each edge, full length of webbing. Stitching will be made in accordance with WP 0012 00, SEWING PROCEDURES, using the specifics in Table 2.
6. Reposition flap edge binding in original location. Restitch binding according to WP 0012 00, SEWING PROCEDURES, using the specifics in Table 2. Lock stitching ends by <sup>3</sup>/<sub>4</sub>-inch.

7. Turn flap to locate flap inside facing up and reposition retainer band keeper in original location. Secure keeper by restitching according to WP 0012 00, SEWING PROCEDURES.

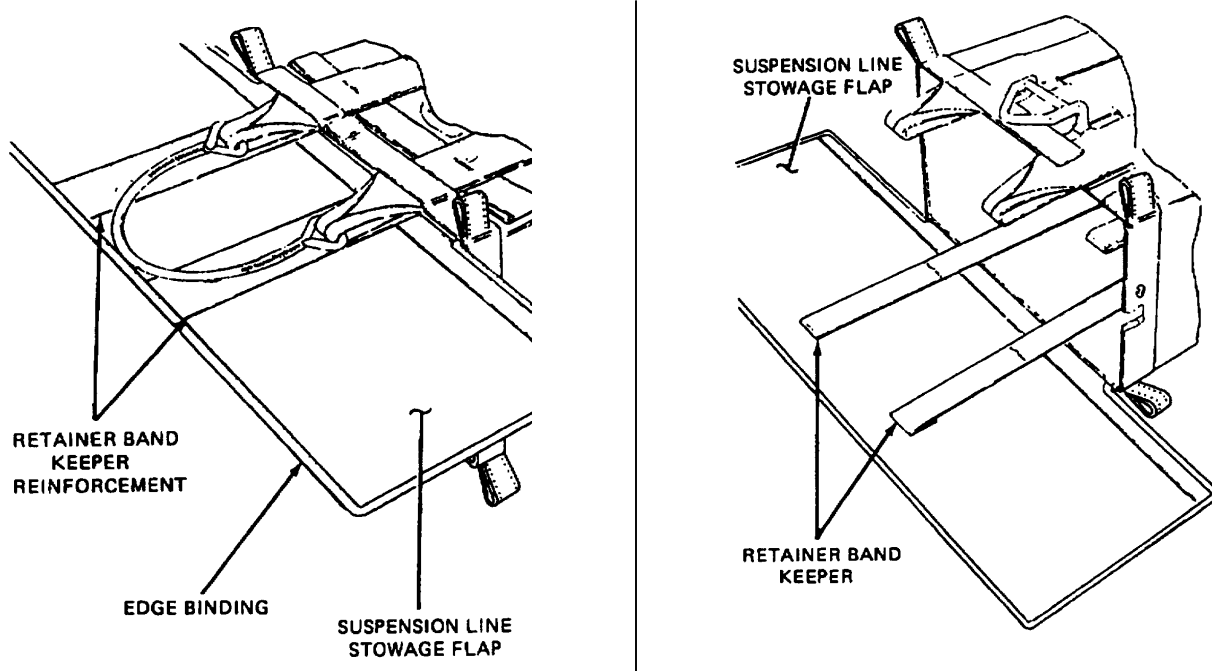

END OF WORK PACKAGE



---

**UNIT MAINTENANCE**  
**28-FOOT DIAMETER CARGO EXTRACTION PARACHUTE**  
**DEPLOYMENT BAG TIE LOOP AND TIE LOOP REINFORCEMENT**

---

**THIS TASK COVERS:**

- Repair
  - Replace
- 

**Tools**

Knife (Item 5, WP 0056 00)  
 Pot, Melting (Item 13, WP 0056 00)  
 Sewing Machine, Medium-Duty (Item 22, WP 0056 00)  
 Shears (Item 24, WP 0056 00)  
 Yardstick (Item 26, WP 0056 00)

**Materials/Parts**

Thread, Nylon, Size FF (Item 32/33, WP 0065 00)  
 Webbing, Nylon, Type IV, 1-IN., OD (Item 41, WP 0065 00)  
 Webbing, Nylon, Type IV, 1½-IN., OD (Item 40, WP 0065 00)

**References**

WP 0012 00

**Personnel Required**

92R (10) Parachute Rigger

**Equipment Condition**

Cleaned (WP 0008 00).  
 Inspected (WP 0009 00).  
 Laid out on work table.

---

**REPAIR**

Stitch and restitch with size FF thread that matches the color of the original stitching, when possible. Lock all straight stitching by backstitching at least ½-inch. Restitch by overstitching each end of the stitch formation by ½-inch. Restitch directly over the original stitching, following the original stitch pattern as closely as possible. Stitch according to WP 0012 00 and Table 2, WP 0012 00.

**REPLACE**

When either a tie loop on deployment bag inside or a tie loop reinforcement on deployment bag outside is damaged, the replacement action will include both items. Replace a tie loop and tie loop reinforcement by fabricating as follows (see figures below and on following page):

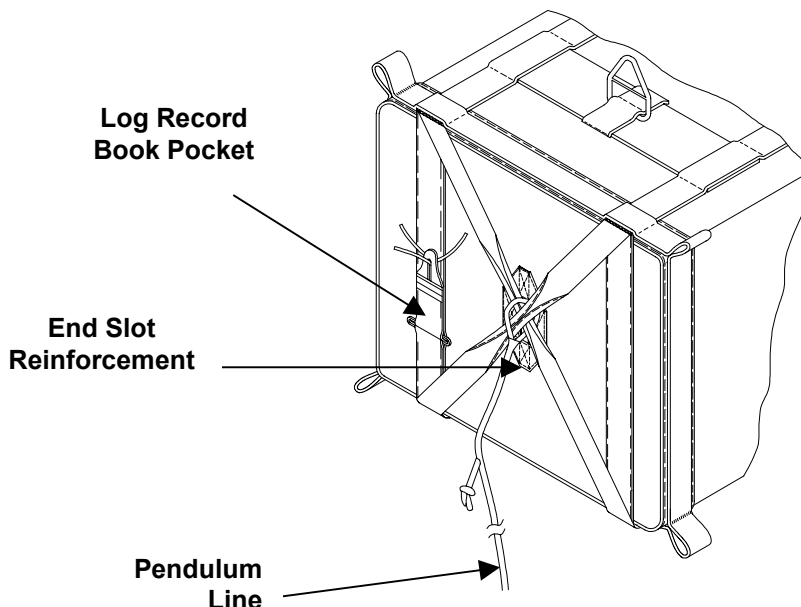

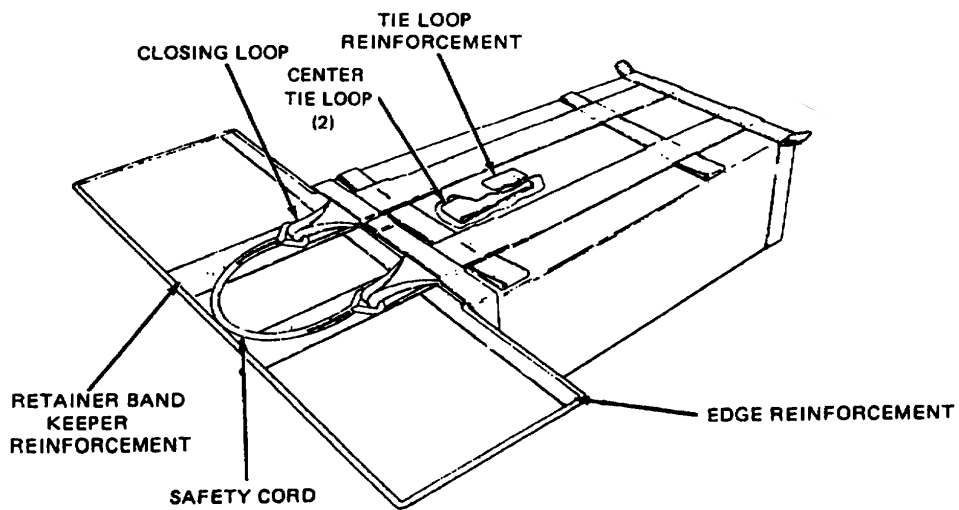
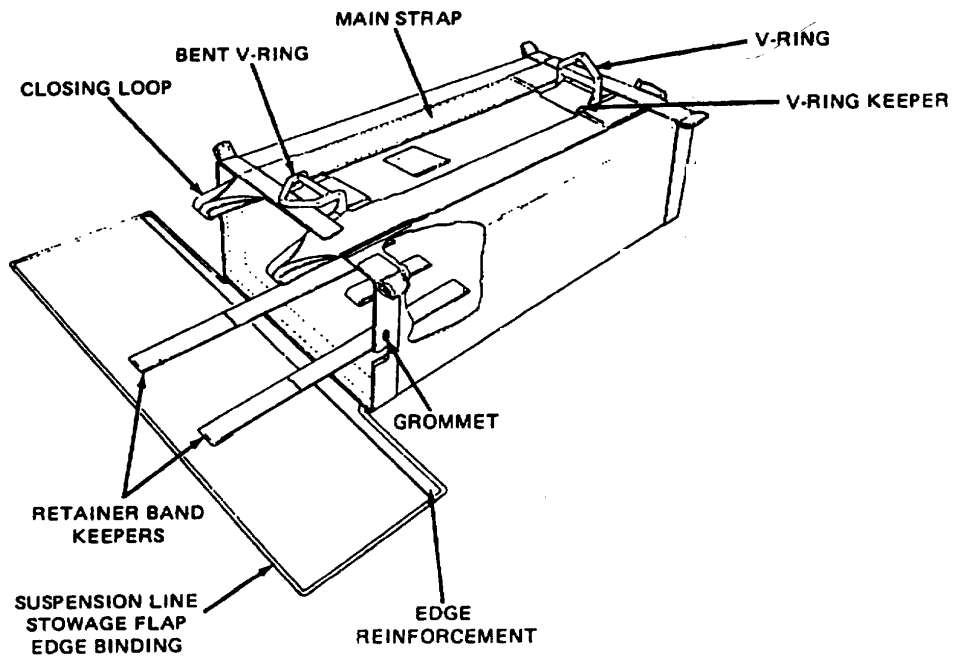

1. Remove applicable original tie loop and tie loop reinforcement by cutting stitching that secures both items to deployment bag.
2. Cut a 11-inch length of 1-inch wide, type IV nylon webbing and a 3-inch length of 1½-inch wide, type IV nylon webbing. Sear ends of both webbing lengths according to WP 0013 00, SEARING AND WAXING.
3. Make an ½-inch long turn under on each end of 3-inch webbing length and position folded webbing in original tie loop reinforcement location on deployment bag outside with turn under ends facing down. Secure replacement reinforcement to deployment bag outside by making a single row of stitching, ⅛-inch in, along each outside edge and stitch a ¾-inch square single-X box-stitch formation with one double end. Stitching will be made with a medium duty sewing machine, 7 to 11 stitches per inch with size FF nylon thread.
4. Double 11-inch webbing length, align ends, and position folded webbing in original tie loop location on inside of deployment bag. Secure replacement tie loop to deployment bag and tie loop reinforcement by stitching a ¾-inch wide by 1-inch long single-X box-stitch formation with one double end. Stitching will be made with a medium-duty sewing machine, 7 to 11 stitches per inch with size FF nylon thread.

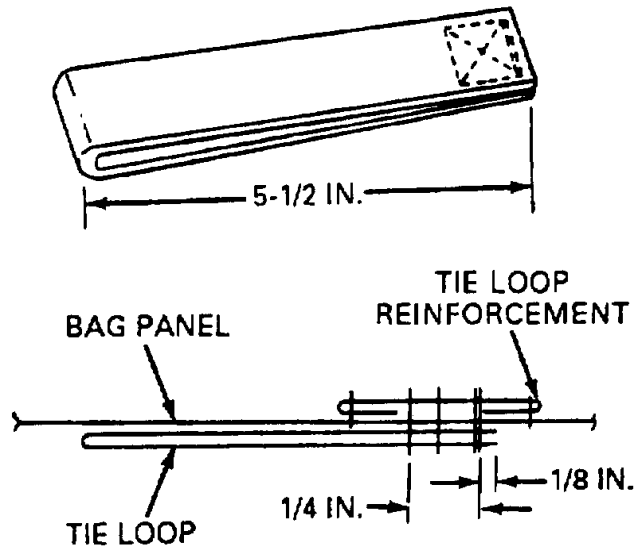

END OF WORK PACKAGE

**THIS PAGE INTENTIONALLY LEFT BLANK**

**UNIT MAINTENANCE**  
**28-FOOT DIAMETER CARGO EXTRACTION PARACHUTE**  
**DEPLOYMENT BAG PENDULUM LINE**

**THIS TASK COVERS:**

- Replace

**Tools**

Aid, Splicing (Item 1, WP 0056 00)  
 Knife (Item 5, WP 0056 00)  
 Knife, Hot Metal (Item 6, WP 0056 00)  
 Shears (Item 24, WP 0056 00)

**Materials/Parts**

Cord, Nylon, Coreless, Type IV, OD (Item 6, WP 0065 00)  
 Marker, China, White (Item 12, WP 0065 00)

**Personnel Required**

92R (10) Parachute Rigger

**Equipment Condition**

Cleaned (WP 0008 00).  
 Inspected (WP 0009 00).  
 Laid out on work table.

**References**

WP 0013 00

**REPLACE**

A pendulum that is damaged or does not conform to the length criteria prescribed in this paragraph will be replaced by fabricating as follows:

1. Remove original pendulum line by cutting loop formed in line at the deployment bag pendulum line attaching point.

**CAUTION**

Do not cut or break the threads in the type IV coreless nylon cord casing while fabricating a pendulum line.

2. Cut an 85-inch length of type IV coreless nylon cord. Taper-cut 1/2-inch of one cord end, sear opposite cord end in accordance with WP 0013 00, SEARING AND WAXING.
3. Using a marking aid, mark cord length at points 6 1/2 and 8-inches from the cord tapered end.

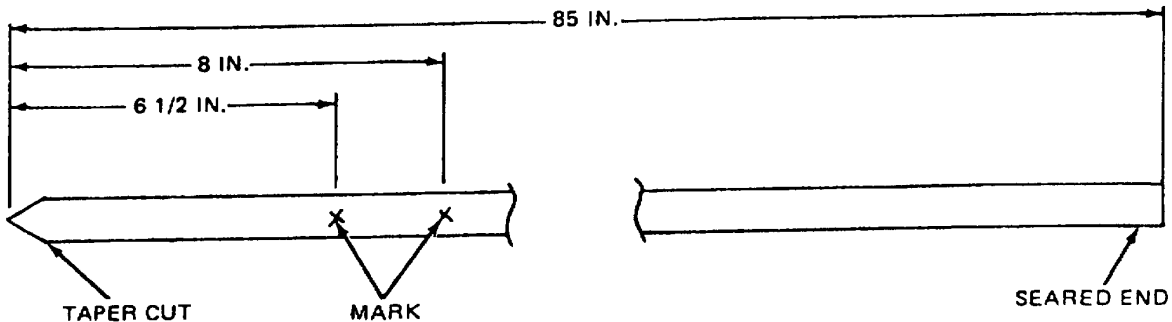

4. Insert splicing aid into cord casing at 8-inch mark and work aid through cord to outside at  $6\frac{1}{2}$ -inch mark.
5. Pass tapered cord end through both deployment bag bridle straps and attach tapered end to splicing aid.
6. Pull splicing aid back into cord casing at  $6\frac{1}{2}$ -inch mark and work aid back through cord casing to outside at 8-inch mark.

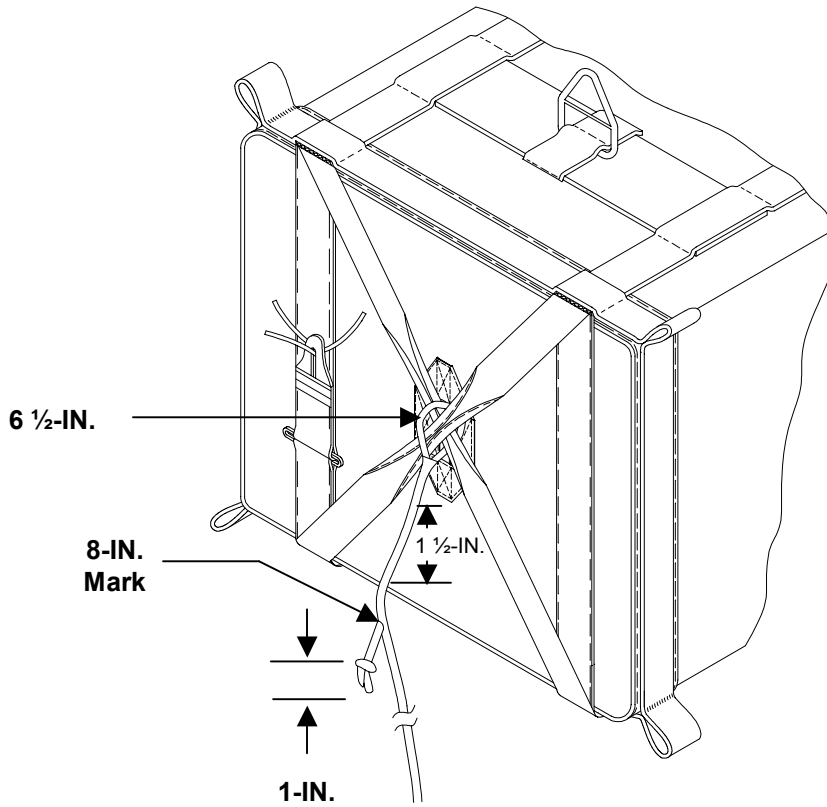

7. Remove tapered cord end from splicing aid. Sear tapered end and make an overhand knot in cord running end at a point 1-inch back from seared tapered end. Stretch cord loop to draw knot against cord casing.

**END OF WORK PACKAGE**

---

**UNIT MAINTENANCE**  
**28-FOOT DIAMETER CARGO EXTRACTION PARACHUTE**  
**LOG RECORD BOOK POCKET**

---

**THIS TASK COVERS:**

- Repair
  - Replace
- 

**Tools**

Knife (Item 5, WP 0056 00)  
 Needle, Tacking (Item 10, WP 0056 00)  
 Sewing Machine, Medium-Duty (Item 22, WP 0056 00)  
 Sewing Machine, Zig-Zag (Item 23, WP 0056 00)  
 Shears (Item 24, WP 0056 00)

**Personnel Required**

92R (10) Parachute Rigger

**Equipment Condition**

Cleaned (WP 0008 00).  
 Inspected (WP 0009 00).  
 Laid out on work table.

**Materials/Parts**

Tape, Lacing & Tying (Item 18, WP 0065 00)  
 Thread, Cotton, Ticket 8/7, Natural (Item 23, WP 0065 00)  
 Thread, Nylon, Size E (Item 30/31, WP 0065 00)

---

**REPAIR**

Repair a log record book pocket as follows:

1. **Stitching.** Using a medium-duty sewing machine, stitch and restitch with size E nylon thread that matches the color of original stitching, when possible. When restitching the tie loops, use a zig-zag sewing machine and restitch with size E nylon thread that matches the color of original stitching, when possible. Lock all straight stitching by backstitching at least  $\frac{1}{2}$ -inch. Restitch directly over the original stitching, following original stitch pattern as closely as possible.

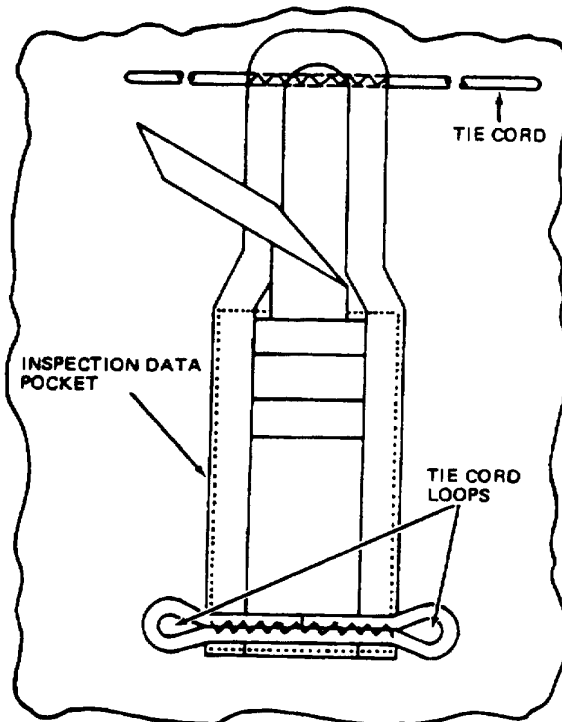

2. Retacking. Replace damaged or missing tacking as follows:
  - a. Remove damaged tacking.
  - b. Using a tacking needle and tape, lacing and tying, retack log record pocket to deployment bag using one turn single lacing. Secure tacking ends with a surgeon's knot and a locking knot.

**REPLACE**

Replace a missing or unserviceable parachute log record book pocket as follows:

1. Position parachute log record book pocket on bottom of deployment bag with pocket bottom edge squared with end slot reinforcement.
2. Hand tack pocket to riser webbing at four corners using a tacking needle and one turn single, tape, lacing and tying as in step 2., Retacking, above.
3. Secure tacking ends with a surgeon's knot and a locking knot. Trim ends to 1/4-inch.

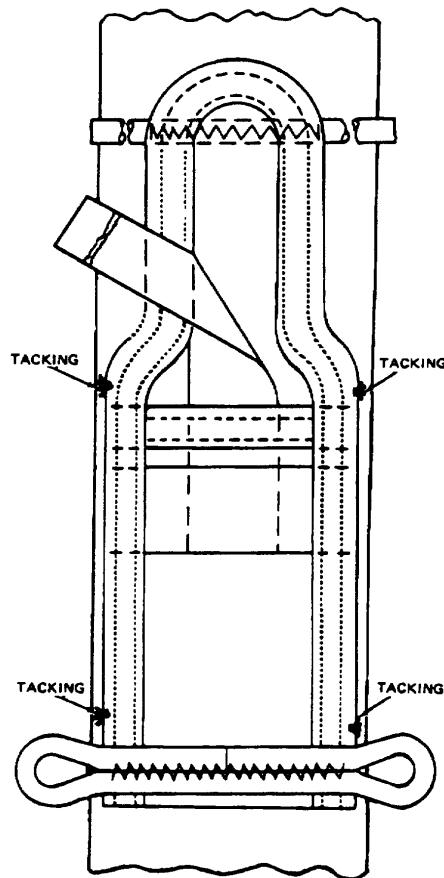

**END OF WORK PACKAGE**



---

**UNIT MAINTENANCE**  
**28-FOOT DIAMETER CARGO EXTRACTION PARACHUTE**  
**DEPLOYMENT BAG SAFETY CORD**

---

**THIS TASK COVERS:**

- Repair
  - Replace
- 

**Tools**

Aid, Splicing (Item 1, WP 0056 00)  
Knife (Item 5, WP 0056 00)  
Sewing Machine, Zig-Zag (Item 23, WP 0056 00)  
Shears (Item 24, WP 0056 00)  
Yardstick (Item 26, WP 0056 00)

**Materials/Parts**

Cord, Nylon, Type IV (Item 6, WP 0065 00)  
Marker, China, White (Item 12, WP 0065 00)  
Thread, Nylon, Size FF (Item 32/33, WP 0065 00)

**Personnel Required**

92R (10) Parachute Rigger

**Equipment Condition**

Cleaned (WP 0008 00).  
Inspected (WP 0009 00).  
Laid out on work table.

**References**

WP 0012 00

---

**REPAIR**

Stitch and restitch with size FF thread, which matches the color of the original stitching, when possible. Lock all straight stitching by backstitching at least ½-inch. Restitch by overstitching each end of the stitch formation by ½-inch. Restitch directly over the original stitching, following the original stitch pattern as closely as possible. Stitch according to WP 0012 00 and Table 2, WP 0012 00.

**REPLACE**

Replace a damaged safety cord by fabricating as follows:

---

**CAUTION**

---

Do not cut or break the threads in the type IV coreless nylon cord casing while fabricating a safety line.

1. Remove the original safety cord from the bottom bag closing loops by cutting the line end loops.
2. Cut a 48-inch length of type IV braided-coreless nylon cord and taper cut each end by ½-inch.

- Using a marking aid, mark the cord length at points 3-, 4- and 7-inches from one tapered end.

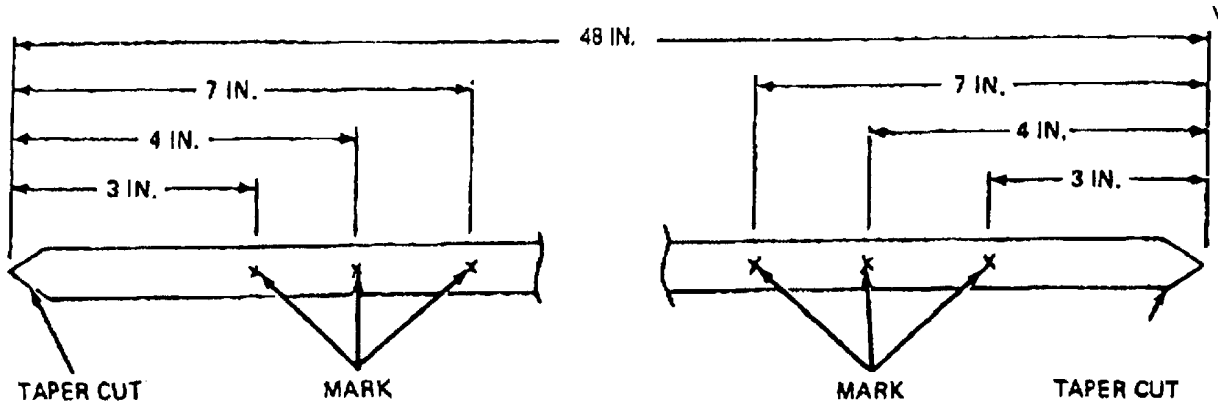

- Insert a splicing needle into the cord casing at the 7-inch mark and work the needle through the cord to the outside at the 4-inch mark.
- Pass three-inches of the marked cord end through one bottom bag closing loop and attach the tapered end to the splicing needle.
- Pull the needle with the attached cord end back into the cord casing at the 4-inch mark and work the needle back through the cord casing until the 3- and 4-inch marks are aligned.
- Hold the aligned marks together and work the needle, with tapered cord end attached, to the outside at the 7-inch mark.
- Remove the tapered cord end from the splicing needle and while holding the aligned 3- and 4-inch marks together, stretch the cord length to allow the tapered cord end to recede inside of the cord casing.
- Secure the formed safety line end loop by stitching a  $\frac{3}{16}$ -inch wide by 3-inch long row of double-throw zig-zag stitching along the center of the cord casing between the two aligned marks and the 7-inch mark. Stitching will be made using a zig-zag sewing machine, 7 to 11 stitches per inch with size FF nylon thread.
- Using a marking aid, mark the running end of the cord length at points 23- and 24-inches from the loose tapered end.
- Pass the cord running end through the right bottom bag closing loop and insert a suitable splicing needle into the cord casing at the 24-inch mark.
- Work the splicing needle through the cord casing and to the outside at the 23-inch mark. Attach the tapered cord end to the splicing needle and work the splicing needle back through the cord casing to the outside at the 24-inch mark.
- Remove the tapered cord from the splicing needle and while holding the aligned 23 and 24-inch marks together, stretch cord length to allow tapered cord to recede inside of cord casing.

14. Secure the formed safety line end loop by stitching a  $\frac{3}{16}$ -inch wide by 3-inch long row of double-throw zig-zag stitching along the center of the cord casing between the two aligned marks and the 7-inch mark. Stitching will be made using a zig-zag sewing machine, 7 to 11 stitches per inch with size FF nylon thread.

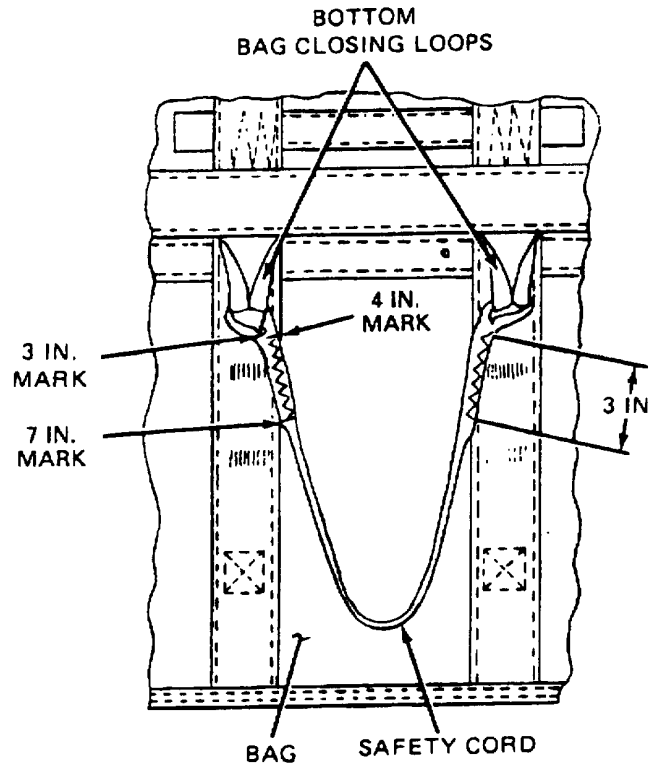

END OF WORK PACKAGE

**THIS PAGE INTENTIONALLY LEFT BLANK**

**UNIT MAINTENANCE**  
**28-FOOT DIAMETER CARGO EXTRACTION PARACHUTE**  
**DEPLOYMENT BAG CLOSING LOOP**

**THIS TASK COVERS:**

- Repair
- Replace

**Tools**

Knife (Item 5, WP 0056 00)  
 Knife, Hot Metal (Item 6, WP 0056 00)  
 Sewing Machine, Medium-Duty (Item 22, WP 0056 00)  
 Sewing Machine, Heavy-Duty (Item 20, WP 0056 00)  
 Shears (Item 24, WP 0056 00)  
 Yardstick (Item 26, WP 0056 00)

**Personnel Required**

92R (10) Parachute Rigger

**Equipment Condition**

Cleaned (WP 0008 00).  
 Inspected (WP 0009 00).

**Materials/Parts**

Thread, Nylon, Size 3 (Item 24/25, WP 0065 00)  
 Webbing, Nylon, Type VIII, 1<sup>23</sup>/<sub>32</sub>-IN. (Item 42, WP 0065 00)

**References**

WP 0012 00, WP 0013 00

**REPAIR**

Using a medium-duty sewing machine, stitch and restitch with size 3, nylon thread that matches the color of the original stitching, when possible. Lock all straight stitching by backstitching at least ½-inch. Restitch by overstitching each end of the stitch formation by ½-inch. Restitch directly over the original stitching, following the original stitch pattern as closely as possible. Stitch according to WP 0012 00 and Table 2, WP 0012 00, SEWING PROCEDURES.

**REPLACE**

Replace a damaged bag closing loop by fabricating as follows:

1. Remove original closing loop by cutting loop webbing flush along edge of bag end reinforcement.
2. Cut a 9½-inch length of 1<sup>23</sup>/<sub>32</sub>-inch wide, type VIII nylon webbing, sear ends according to WP 0013 00, SEARING AND WAXING.
3. Mark webbing length at a point 2¾-inches from each end.
4. Between two marks made in 3. above, roll webbing edges into center of webbing width and secure each rolled edge by stitching a 4-inch long row of stitching according to details in the illustration below. Stitching will be made with a medium-duty sewing machine, 7 to 11 stitches per inch and size 3 nylon thread.

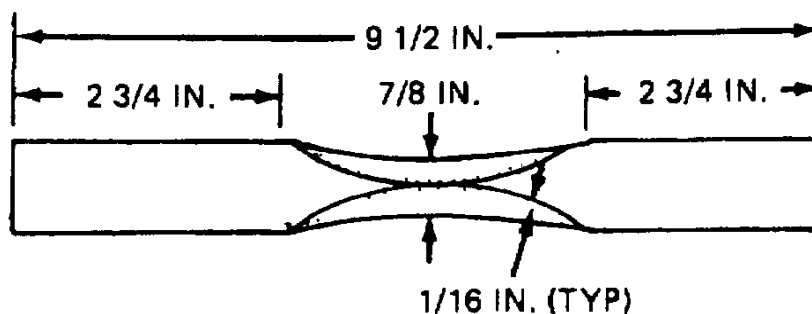

**Construction Details**

5. Double webbing length with rolled edges facing out and align webbing ends.
6. Position formed loop in original closing loop location with aligned webbing end placed over applicable main strap and bag end reinforcement. Using either a medium-duty or heavy-duty sewing machine, secure webbing ends bag and reinforcement, and main strap by stitching a 2<sup>3</sup>/<sub>4</sub>-inch four-point WW-switch formation, according to the details in the illustration below. Stitching will be made with a heavy-duty sewing machine, 7 to 11 stitches per inch and size 3 nylon thread.

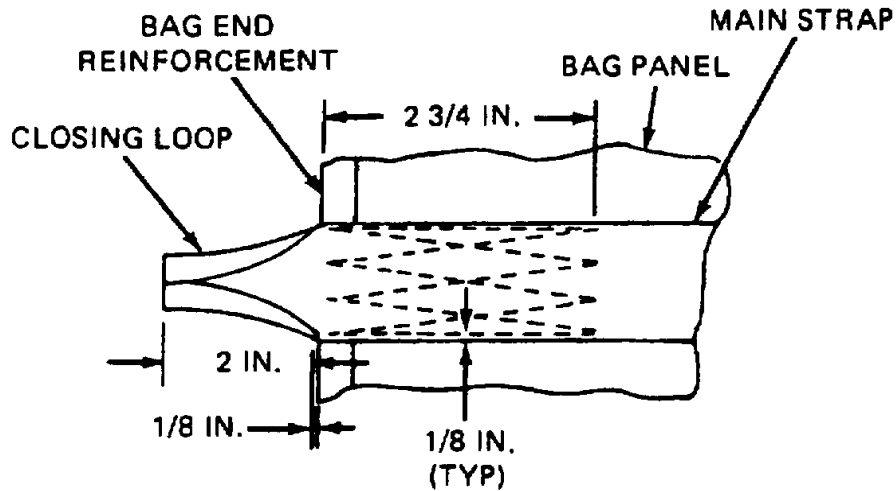

Installation Details

END OF WORK PACKAGE

**UNIT MAINTENANCE**  
**28-FOOT DIAMETER CARGO EXTRACTION PARACHUTE**  
**DEPLOYMENT BAG STOWAGE FLAP EDGE BINDING**

**THIS TASK COVERS:**

- Repair

**Tools**

Aid, Splicing (Item 1, WP 0056 00)  
 Knife (Item 5, WP 0056 00)  
 Sewing Machine, Medium-Duty (Item 22, WP 0056 00)  
 Shears (Item 24, WP 0056 00)  
 Yardstick (Item 26, WP 0056 00)

**Personnel Required**

92R (10) Parachute Rigger

**Equipment Condition**

Cleaned (WP 0008 00).  
 Inspected (WP 0009 00).  
 Laid out on work table.

**Materials/Parts**

Tape, Nylon, Type III, 3/4-IN., OD (Item 20, WP 0065 00)  
 Thread, Nylon, Size FF (Item 32/33, WP 0065 00)

**References**

WP 0012 00

**REPAIR**

1. **Stitching.** Stitch and restitch with size FF thread, that matches the color of the original stitching, when possible. Lock all straight stitching by backstitching at least 1/2-inch. Restitch by over stitching each end of the stitch formation by 1/2-inch. Restitch directly over the original stitching, following the original stitch pattern as closely as possible. Stitch according to WP 0012 00 and Table 2, WP 0012 00, SEWING PROCEDURES.
2. **Splicing.** Splice an edge binding (an unlimited number of times) as follows:
  - a. Cut a length of 3/4-inch wide nylon tape 2-inches longer than damaged area.
  - b. Make a 1/2-inch fold under on each end of tape length.
  - c. Center and fold tape lengthwise over edge of the damaged area. Secure splice by stitching a boxstitch formation, 1/16-inch in from each edge, along full length of splice material.

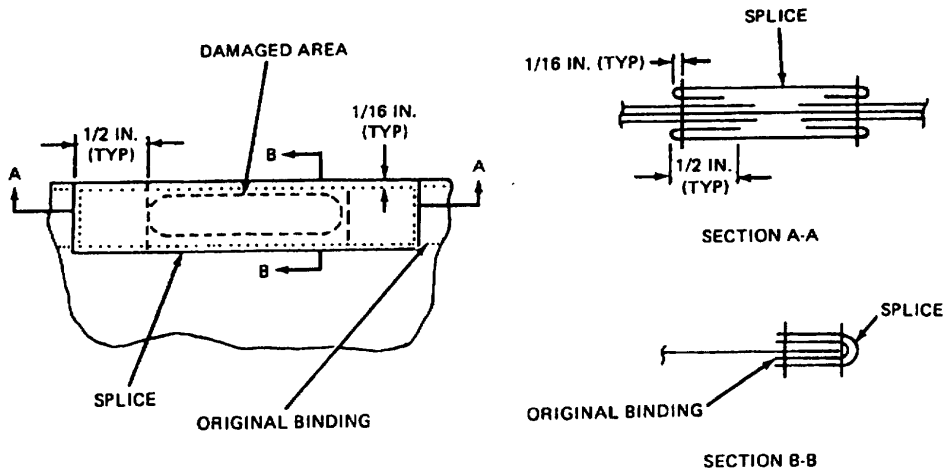

**END OF WORK PACKAGE**

**THIS PAGE INTENTIONALLY LEFT BLANK**



---

**UNIT MAINTENANCE**  
**28-FOOT DIAMETER CARGO EXTRACTION PARACHUTE**  
**DEPLOYMENT BAG PANELS AND FLAPS**

---

**THIS TASK COVERS:**

- Repair
- 

**Tools**

Sewing Machine, Darning (Item 19, WP 0056 00)  
 Sewing Machine, Medium-Duty (Item 22, WP 0056 00)  
 Shears (Item 24, WP 0056 00)

**Materials/Parts**

Cloth, Nylon Duck, Type III (Item 4, WP 0065 00)  
 Marker, China, White (Item 12, WP 0065 00)  
 Push Pins (Local Purchase)  
 Thread, Nylon, Size FF (Item 32/33, WP 0065 00)

**Personnel Required**

92R (10) Parachute Rigger

**Equipment Condition**

Cleaned (WP 0008 00).  
 Inspected (WP 0009 00).  
 Laid out on work table.

**References**

WP 0012 00, WP 0014 00

---

**REPAIR**

1. **Stitching.** Stitch and restitch with thread that matches the color the original stitching, when possible. Lock all straight stitching by backstitching at least ½-inch. Restitch by overstitching each end of the stitch formation by ½-inch. Restitch directly over the original stitching, following the original stitch pattern as closely as possible. Stitch according to WP 0012 00, SEWING PROCEDURES.
2. **Darning.** Darn a hole or tear that does not exceed ¾-inch in length or diameter according to procedures in WP 0012 00 using specifics in Table 2. There is no limit to the number of darns that may be made on the bag panels and flaps.
3. **Patching.** Patch a hole or tear which exceeds ¾-inch in length or diameter using 7.25-oz nylon duck cloth using a medium-duty sewing machine, 7 to 11 stitches per inch and size FF nylon thread. There is no limit to the number of patches that may be made on the bag panels and flaps as follows:

**NOTE**

---

Patches may be applied to the inside or outside of the deployment bag.

The damaged area must be accessible and there must be at least 1¼-inches of undamaged material remaining on all sides of the affected area.

- a. Smooth fabric around the damaged area, and secure with pushpins. Do not pin damaged area.
- b. Using a marking aid of contrasting color, mark a square or rectangle around the area to be patched; ensure one side of marked square or rectangle is parallel to warp or filling of fabric.
- c. Cut damaged area fabric along lines made in b. above. Further cut fabric diagonally at each corner to allow a ½-inch foldback at raw edges.

- d. Make a 1/2-inch foldback on each raw edge. Pin and baste each foldback to complete prepared hole. Basting will be performed using procedures in WP 0012 00, SEWING PROCEDURES.
- e. Using duck cloth, mark and cut a patch 2 1/2-inches wider and longer than inside measurements of the prepared hole. Ensure that patch material is marked, and cut along the warp or filling of fabric.
- f. Center patch material over prepared hole and ensure the warp or filling of patch material matches warp or filling of fabric being patched. Pin patch material in position.
- g. Make a 1/2-inch foldunder on each edge of patch material and baste patch to prepared area. Basting will be performed using procedures in WP 0012 00, SEWING PROCEDURES.
- h. Remove pushpins securing the item to repair table and secure the patch by stitching, using applicable details in the illustration below and the stitching specifics outlined in applicable item maintenance publication. Make first row of stitching completely around patch. Turn deployment bag inside out and make second row of stitching around prepared hole. Stitching will be performed in according with WP 0012 00, SEWING PROCEDURES.

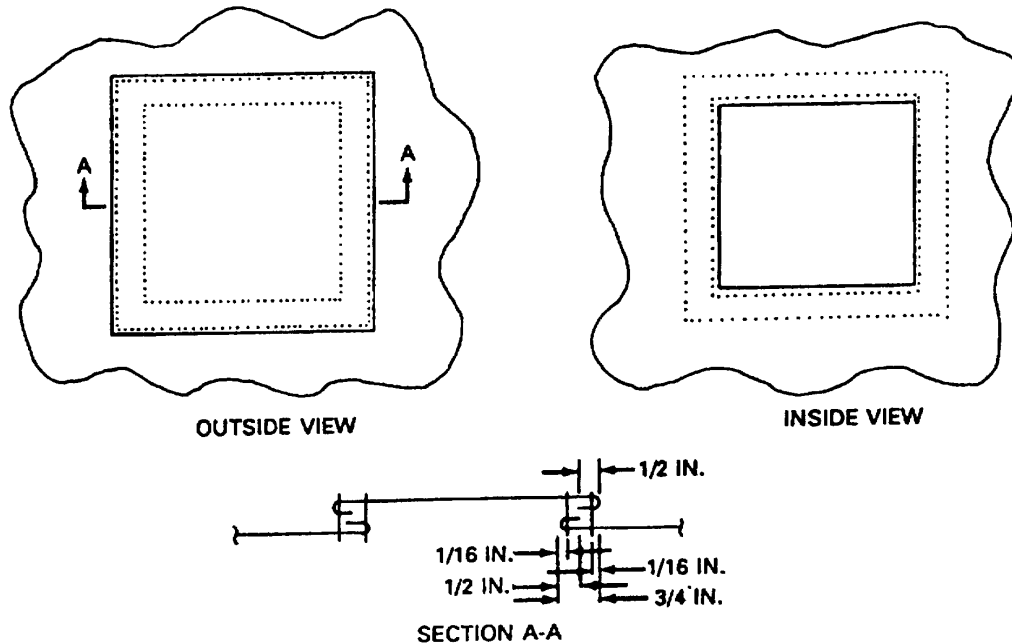

4. Restenciling. As required, restencil identification markings using procedures in WP 0014 00, MARKING AND STENCILLING.

END OF WORK PACKAGE

**UNIT MAINTENANCE**  
**28-FOOT DIAMETER CARGO EXTRACTION PARACHUTE**  
**DEPLOYMENT BAG STOWAGE FLAP EDGE REINFORCEMENT**

**THIS TASK COVERS:**

- Repair

**Tools**

Knife (Item 5, WP 0056 00)  
 Knife, Hot Metal (Item 6, WP 0056 00)  
 Sewing Machine, Medium-Duty (Item 22, WP 0056 00)  
 Shears (Item 24, WP 0056 00)  
 Yardstick (Item 26, WP 0056 00)

**Personnel Required**

92R (10) Parachute Rigger

**Equipment Condition**

Cleaned (WP 0008 00).  
 Inspected (WP 0009 00).  
 Laid out on work table.

**Materials/Parts**

Thread, Nylon, Size FF (Item 32/33, WP 0065 00)  
 Webbing, Nylon, Type IV, 1-IN., OD (Item 41, WP 0065 00)

**References**

WP 0012 00, WP 0013 00

**REPAIR**

1. **Stitching.** Stitch and restitch with size FF thread, that matches the color of the original stitching, when possible. Lock all straight stitching by backstitching at least 1/2-inch. Restitch by overstitching each end of the stitch formation by 1/2-inch. Restitch directly over the original stitching, following the original stitch pattern as closely as possible. Stitch according to WP 0012 00 and Table 2, WP 0012 00, SEWING PROCEDURES.
2. **Splicing.** Splice a stowage flap edge reinforcement (an unlimited number of times) as follows.
  - a. Cut a length of 1-inch wide, type IV nylon webbing long enough to extend 2 3/4-inches beyond each side of damaged area; sear ends according to WP 0013 00, SEARING AND WAXING.
  - b. Center webbing length lengthwise over damaged area including edge binding, and secure the splice by stitching a box-stitch formation, 1/8-inch in from each edge, along full length of splice material. Stitching will be made with medium-duty sewing machine, 7 to 11 stitches per inch with size FF nylon thread.

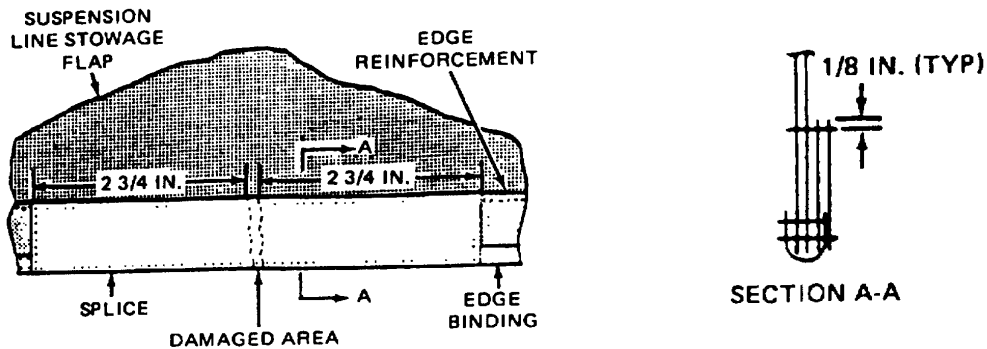

**END OF WORK PACKAGE**

**THIS PAGE INTENTIONALLY LEFT BLANK**

**CHAPTER 4**

**DIRECT SUPPORT MAINTENANCE INSTRUCTIONS**  
**FOR**  
**PARACHUTE, CARGO TYPE:**  
**28-FOOT DIAMETER, CARGO**  
**EXTRACTION PARACHUTE**

**THIS PAGE INTENTIONALLY LEFT BLANK**

---

**DIRECT SUPPORT MAINTENANCE  
28-FOOT DIAMETER CARGO EXTRACTION PARACHUTE  
SEWING PROCEDURES**

---

**THIS TASK COVERS:**

- Basting and Temporary Tacking
  - Stitching and Restitching
  - Darning
  - Zig-Zag Sewing
- 

**Tools**

Specified in paragraph applicable to the item being repaired.

**Personnel Required**

92R (10) Parachute Rigger

**Materials/Parts**

Specified in paragraph applicable to the item being repaired.

**Equipment Condition**

Unpacked. Cleaned canopy with defects recorded.

**References**

DA PAM 738-751

---

**NOTE**

Sewing requirements will vary according to the type of item being repaired and the type of repair being made. The type of sewing machine, type of thread, the stitch range, and the stitch pattern, if applicable, required to accomplish a sewing procedure will be specified in the paragraph applicable to the item being repaired. All original stitching that is cut during the performance of a sewing procedure will be removed from the applicable item. Immediately after the accomplishment of a machine sewing procedure, trim thread ends to a point as close as possible to the material that has been sewn.

**BASTING AND TEMPORARY TACKING**

Basting and temporary tacking are hand-sewing methods used to temporarily hold layers of cloth fabric together while a repair is being performed. The following is a list of procedures which apply to basting and temporary tacking actions:

1. Basting and temporary tacking should be made using thread that is of a contrasting color to the material being worked.
2. On small cargo parachute canopies, basting will be done using thread identified in individual item repair procedure.
3. When basting, do not tie knots at any point in the thread length. Also, the sewing should be done with two stitches per inch.
4. Temporary tacking will usually be done using a length of size E nylon thread (Item 30/31, WP 0065 00). However, an alternate type thread may be specified within the paragraph applicable to the item.
5. Immediately upon completion of a repair, remove previously made basting or temporary tacking stitches.

**STITCHING AND RESTITCHING**

Perform stitching and restitching as follows, referring to Table 1 and Table 2:

1. Parachute canopy assemblies. The stitching and restitching made on parachute canopies should be accomplished with thread that is contrasting in color to the fabric being restitched. If contrasting color thread is not available, thread of matching color may be used, providing all other specifications are met. Straight stitching and restitching on parachute canopy assemblies should be locked by at least 2-inches at each end of a stitch row, when possible. Zig-zag stitching does not require locking; however, zig-zag restitching should extend at least ¼-inch into undamaged stitching at each end, when possible. When restitching parachute canopy assemblies, stitch directly over the original stitching and follow the original stitch pattern as closely as possible.

**Table 1. Sewing Machine Code Symbols**

CODE SYMBOL	SEWING MACHINE
LD	SEWING MACHINE, INDUSTRIAL: General sewing; 301 stitch; light-duty; NSN 3530-01-177-8590.
MD ZZ	SEWING MACHINE, INDUSTRIAL: Zig-zag; 308 stitch; medium-duty; NSN 3530-01-181-1421.
LD ZZ	SEWING MACHINE, INDUSTRIAL: Zig-zag; 308 stitch; light-duty; NSN 3530-01-181-1420.
HD	SEWING MACHINE, INDUSTRIAL: General sewing; 301 stitch; heavy-duty; NSN 3530-01-177-8588.
MD	SEWING MACHINE, INDUSTRIAL: General sewing; 301 stitch; medium-duty; NSN 3530-01-177-8591.
DN	SEWING MACHINE, INDUSTRIAL: Darning; lock stitch; NSN 3530-01-177-8589.
LHD	SEWING MACHINE, INDUSTRIAL: 301 stitch; light, heavy-duty; NSN 3530-01-186-3079.
ND	SEWING MACHINE, INDUSTRIAL: 301 stitch; double needle; NSN 3530-01-182-2873.

**Table 2. Stitching and Restitching Specifications**

COMPONENT	RECOMMENDED SEWING MACHINE (CODE SYMBOL)	STITCHES PER INCH	THREAD SIZE
The 28-Foot-Diameter Cargo Extraction Parachute			
Vent line	ZZ	7 to 11	FF
Bridle Centering line	ZZ	7 to 11	E
Gore Section	LD	7 to 11	E
Suspension line	MD	5 to 8	3



- a. Other parachute items. Stitching and restitching on other parachute items constructed from cloth, canvas, and webbing should be accomplished with thread that matches the color of the original stitching, when possible. Backstitching at least ½-inch should lock all straight stitching. Restitching should be locked by overstitching each end of the stitch formation by ½-inch. Zig-zag stitching does not require locking; however, zig-zag restitching should extend at least ¼-inch into undamaged stitching at each end, when possible. Restitching should be made directly over the original stitching, following the original stitch pattern as closely as possible.
2. Darning. (Refer to Tables 1 and Table 2.) Darning is a sewing procedure used to repair limited size holes, rips, and tears in assorted airdrop items constructed from textile material such as parachute canopy gore sections, and the cloth, and reinforcement webbing of packs. A darning repair may be made either by hand or sewing machine, depending upon the method preferred and the availability of equipment. However, a darning machine should be used to darn small holes and tears where fabric is missing. Darning of previously patched material can be performed provided darning size limitations prescribed in the paragraph applicable to the item are not exceeded. A darning repair will be performed using the following procedures, as appropriate:

a. Machine darning. Proceed as follows:

- (1) Using an authorized marking aid of contrasting color, mark a square around the damaged area and ensure the marking is at least ¼-inch back from each edge of the damaged area. The marking will be made with the warp and the filling of the material.
- (2) Darn the damaged area by sewing the material in a back-and-forth manner, using size A or E nylon thread, allowing the stitching to run with the warp or filling of the fabric.

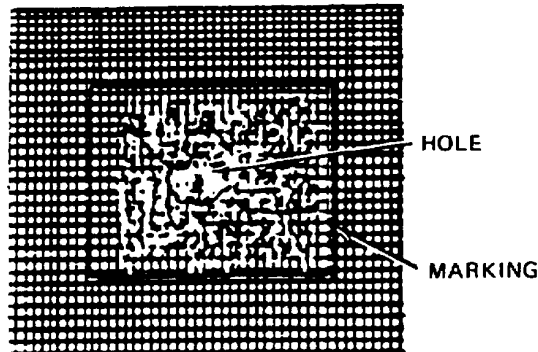

- (3) Turn the material and stitch back and forth across the stitching made in (2) above until the hole or tear is completely darned.

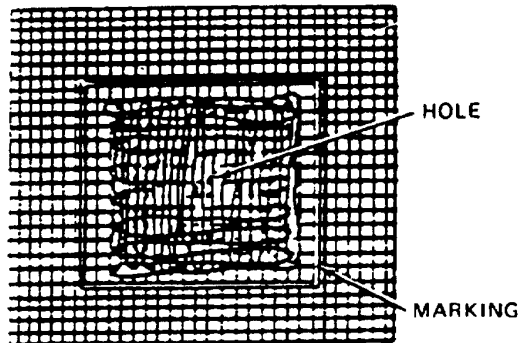

- (4) If applicable, restencil informational data, gore number(s), or identification marks using the criteria in WP 0048 00, MARKING AND STENCILLING.
- b. Hand darning. When repair of a hole or tear is made by hand darning, the darn should match the original weave of the damaged material as closely as possible. Hand darning will be performed as follows:
- (1) Using an authorized marking aid of contrasting color, mark a square around the damaged area and ensure the marking is at least ¼-inch back from edge of the damaged area. The marking will be made with the warp and the filling of the material.
  - (2) Using a darning needle and a length of size A or E nylon thread, begin darning at one corner of the marked area. Working in the direction of the fabric warp or filling, pass the needle and thread back and forth, through the material until the opposite diagonal corner of the marked area is reached.

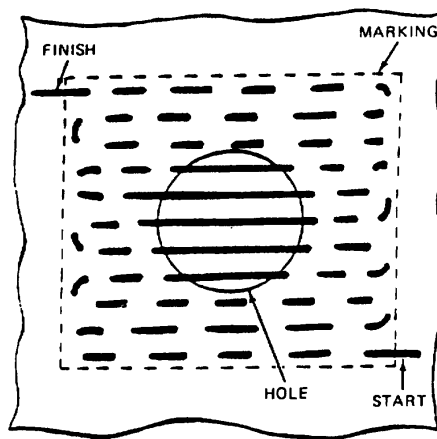

- (3) Turn the material and weave the needle and thread back and forth across the stitching made in (2), above, until the hole is completely darned.

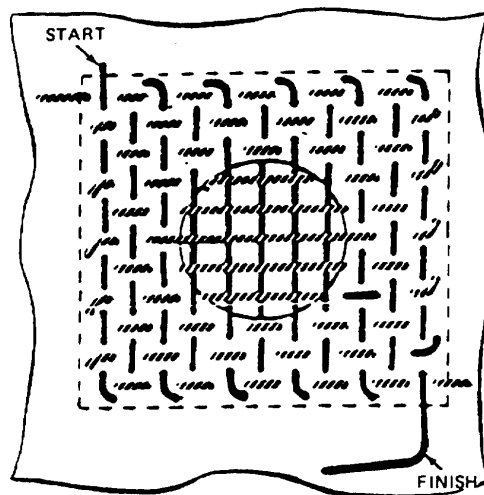

(4) If applicable, restencil informational data or identification marks as outlined in WP 0048 00, MARKING AND STENCILLING.

3. Zig-Zag Sewing. (Refer to Table 1 and Table 2.) Airdrop items, except parachute canopies, made from textile materials that have sustained cut or tear damage may be repaired by zig-zag sewing provided the applicable damaged area does not have any material missing and the cut or tear is straight or L-shaped. Should the damaged area be irregular shaped or have material missing, the repair will be achieved by either darning or patching, as required. A zig-zag sewing repair will be accomplished with a zig-zag sewing machine, using the following procedures:

- a. Set the sewing machine to the maximum stitch width.
- b. Beginning at a point 1/4-inch beyond one end of the cut or tear, stitch lengthwise along the damaged area to a point 1/4-inch beyond the opposite end of the cut or tear.



**STRAIGHT CUT OR TEAR STITCHING**

- c. The cited stitching procedure will also apply to an L-shaped cut or tear.

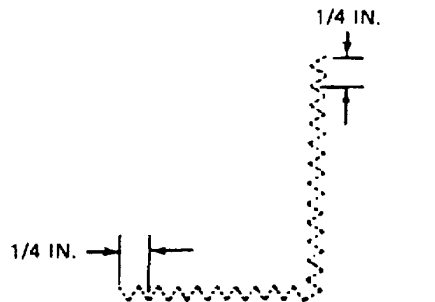

**L-SHAPED CUT OR TEAR STITCHING**

- d. If applicable, restencil informational data or identification marks as prescribed in WP 0048 00, MARKING AND RESTENCILLING.

**END OF WORK PACKAGE**

**THIS PAGE INTENTIONALLY LEFT BLANK**

---

**DIRECT SUPPORT MAINTENANCE  
28-FOOT DIAMETER CARGO EXTRACTION PARACHUTE  
SEARING AND WAXING**

---

**THIS TASK COVERS:**

- Searing
  - Waxing
- 

**Tools**

Knife, Metal, Hot (Item 6, WP 0056 00)  
Pot, Melting, Electric (Item 13, WP 0056 00)

**Materials/Parts**

Beeswax, Technical (Item 2, WP 0065 00)  
Wax, Paraffin, Technical (Item 34, WP 0065 00)

**Personnel Required**

92R (10) Parachute Rigger

**Equipment Condition**

Unpacked.

---

---

**CAUTION**

---

Cotton tape, webbing, or cord will not be seared.

---

**NOTE**

---

Fabric materials such as cord, tape, and webbing, that are cut for use in the maintenance of parachutes will normally be heat-seared or dipped in a melted wax mixture, as applicable, to prevent the material from fraying or unraveling. However, in some instances the preparation of the material may not be necessary and will be specified accordingly.

**SEARING**

The cut ends of nylon tape, webbing, and cord lengths may be prepared by heat-searing; this is performed by pressing the raw end of the material against a hot metal surface (knife) until the nylon has melted sufficiently. Avoid forming a sharp edge or lumped effect on the melted end.

**WAXING**

The fraying or unraveling of cotton or nylon tape, webbing, and cord length ends may be prevented by dipping ½-inch of the raw end of the material into a thoroughly melted mixture of half beeswax and half paraffin in an electric melting pot. The wax temperature should be substantial enough to ensure the wax completely penetrates the material rather than just coating the exterior fabric.

**END OF WORK PACKAGE**

**THIS PAGE INTENTIONALLY LEFT BLANK**

---

**DIRECT SUPPORT MAINTENANCE  
28-FOOT DIAMETER CARGO EXTRACTION PARACHUTE  
MARKING AND RESTENCILLING**

---

**THIS TASK COVERS:**

- Marking
  - Restencilling
  - Remarking and Restencilling
- 

**Tools**

Brush, Stencilling (Item 3, WP 0056 00)  
Machine, Stencil Cutting (Item 8, WP 0056 00)

**Materials/Parts**

Ink, Marking, Parachute, Strata-Blue (Item 10, WP 0065 00)  
Marker, Felt Tip, Black (Item 13, WP 0065 00)  
Pen, Ball Point (Item 14, WP 0065 00)  
Stencilboard, Oiled (Item 16, WP 0065 00)

---

**Personnel Required**

92R (10) Parachute Rigger

**Equipment Condition**

Laid out on packing table or other suitable area.

---

---

**NOTE**

---

Stenciling should be used whenever possible. A ballpoint pen or felt tip marker should be used only where stenciling is not possible, or when stenciling devices are not available. Any type ballpoint pen using black or blue ink may be used for marking on labels only. Original stenciled data or marking that becomes faded, illegible, obliterated, or removed as a result of performing a repair procedure will be remarked with a ballpoint pen, felt tip marker, or restenciled. All marking or restenciling will be done on, or as near as possible to, the original location and should conform to the original lettering type and size.

**MARKING**

Using marking devices, such as ballpoint pen or felt tip marker, mark on, or as near as possible to, original location and conform to original lettering type and size.

**RESTENCILING**

Proceed as follows:

1. Cut oiled stencilboard to original lettering type and size of data to be restenciled.
2. Place cut stencilboard over, or as near as possible to, original marking to be restenciled.
3. Place additional sheet of stencilboard beneath the area to be restenciled to prevent the marking ink from penetrating to the areas.
4. Hold stencilboard in place and, using stenciling brush filled with parachute marking ink, restencil original marking.

**REMARKING AND RESTENCILING**

Remark or restencil original stenciled data or markings that become faded, illegible, obliterated or have been removed as a result of performing a repair procedure. Ensure all marking or restenciling is on, or as near as possible to, the original location and conforms to the original lettering type and size.

**END OF WORK PACKAGE**



**DIRECT SUPPORT MAINTENANCE**  
**28-FOOT DIAMETER CARGO EXTRACTION PARACHUTE**  
**VENT LINE**

**THIS TASK COVERS:**

- Replace

**Tools**

Knife (Item 5, WP 0056 00)  
 Knife, Hot Metal (Item 6, WP 0056 00)  
 Sewing Machine, Light-Duty (Item 21, WP 0056 00)  
 Sewing Machine, Zig-Zag (Item 23, WP 0056 00)  
 Shears (Item 24, WP 0056 00)  
 Yardstick (Item 26, WP 0056 00)

**Personnel Required**

92R (10) Parachute Rigger

**Equipment Condition**

Cleaned (WP 0008 00).  
 Inspected (WP 0009 00).  
 Unpacked, laid flat on repair table.

**Materials/Parts**

Thread, Nylon, Size E (Item 30/31, WP 0065 00)  
 Webbing, Nylon, Tubular,  $\frac{3}{4}$ -IN., Natural (Item 38, WP 0065 00)

**References**

WP 0046 00

**REPLACE**

Replace missing or damaged vent lines as follows:

1. Remove an original vent line by cutting the stitching at each end of the line.
2. Cut a length of  $\frac{3}{4}$ -inch wide tubular nylon webbing equal to the length of an adjacent affixed vent line; sear the ends.
3. Mark the webbing length at points six-inches from each end.
4. Position one end of the webbing length in the original location of one vent line and align the six-inch mark with the upper edge of the vent reinforcement band (upper lateral band).
5. Beginning at a point  $\frac{1}{8}$ -inch back from the vent reinforcement band (upper lateral band) upper edge, secure the positioned webbing end to the radial tape by stitching two  $\frac{5}{32}$ -inch wide rows of double-throw zig-zag stitching to a point  $\frac{1}{2}$ -inch beyond the positioned webbing length. Stitching will be made using the specifics in Table 2, WP 0046 00, SEWING PROCEDURES.

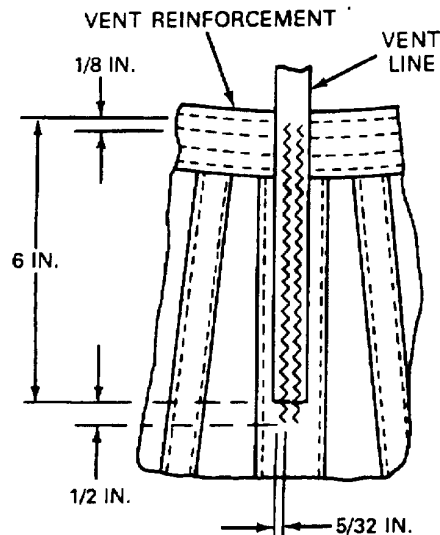

6. Pass the webbing length running end through the bridle centering line and the vent loop. Secure the webbing running end to the opposite side of the canopy in the original vent line end location, using procedures in step 5., above.

**END OF WORK PACKAGE**

**DIRECT SUPPORT MAINTENANCE  
28-FOOT DIAMETER CARGO EXTRACTION PARACHUTE  
BRIDLE CENTERING LINE**

**THIS TASK COVERS:**

- Replace

**Tools**

Knife (Item 5, WP 0056 00)  
 Knife, Hot Metal (Item 6, WP 0056 00)  
 Sewing Machine, Zig-Zag (Item 23, WP 0056 00)  
 Shears (Item 24, WP 0056 00)  
 Yardstick (Item 26, WP 0056 00)

**Personnel Required**

92R (10) Parachute Rigger

**Equipment Condition**

Cleaned (WP 0008 00).  
 Inspected (WP 0009 00).  
 Unpacked, canopy laid flat.

**Materials/Parts**

Marker, Felt-Tip, Black (Item 13, WP 0065 00)  
 Thread, Nylon, Size E (Item 30/31, WP 0065 00)  
 Webbing, Nylon, Tubular 3/4-IN., Natural (Item 38, WP 0065 00)

**References**

WP 0012 00

**REPLACE**

Replace a damaged bridle centering line by fabricating as follows:

1. Remove a bridle centering line by cutting the stitching at each end of the line.
2. Cut a 12-inch length of 3/4-inch wide tubular nylon webbing and sear the ends.
3. Position the webbing length in the original bridle centering line location on the underside center of the original attaching vent line. Make a contrasting colored mark at a point three-inches on each side of the webbing length center and on the vent line.
4. Beginning at one 3-inch mark, which is aligned with the vent line marking, secure one end of the webbing length to the vent line by stitching two 5/32-inch wide rows of double-throw zig-zag stitching to a point 1/2-inch beyond the adjacent webbing end. Stitching will be made using the specifics in Table 2, WP 0012 00.

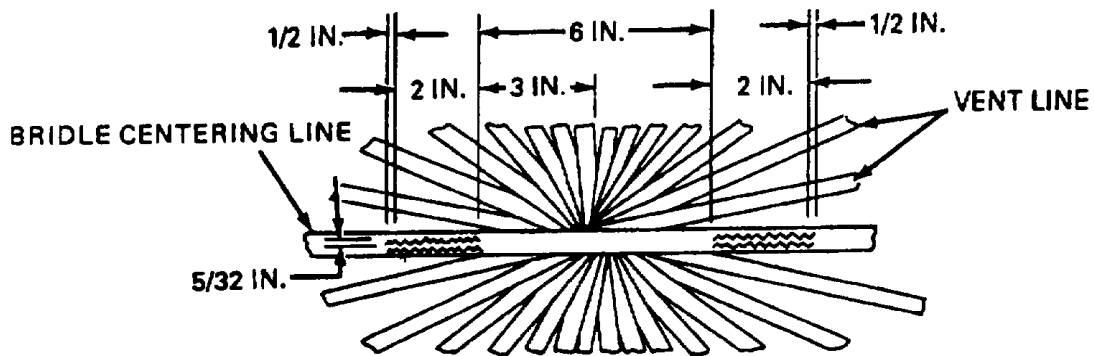

**END OF WORK PACKAGE**

**THIS PAGE INTENTIONALLY LEFT BLANK**

**DIRECT SUPPORT MAINTENANCE**  
**28-FOOT DIAMETER CARGO EXTRACTION PARACHUTE**  
**GORE SECTION**

**THIS TASK COVERS:**

- Replace

**Tools**

- Brush, Stenciling (Item 3, WP 0056 00)
- Knife (Item 5, WP 0056 00)
- Needle, Tacking (Item 10, WP 0056 00)
- Pot, Melting, Electric (Item 13, WP 0056 00)
- Sewing Machine, Darning (Item 19, WP 0056 00)
- Sewing Machine, Light-Duty (Item 21, WP 0056 00)
- Shears (Item 24, WP 0056 00)
- Yardstick (Item 26, WP 0056 00)

**Personnel Required**

92R (10) Parachute Rigger

**Equipment Condition**

Cleaned (WP 0008 00).  
 Inspected (WP 0009 00).  
 Unpacked, parachute laid out on table.

**Materials/Parts**

- Cloth, Nylon, Parachute, Type II, 3.5 Oz. (Item 5, WP 0065 00)
- Marker, China, White (Item 12, WP 0065 00)
- Pushpins (Local Purchase)
- Thread, Nylon, Size E (Item 30/31, WP 0065 00)

**References**

WP 0046 00, WP 0048 00

**REPLACE**

When replacing gore sections, use 3.5-ounce muslin cloth of same color as that being replaced. If the same color cloth is not available, another color may be used. When replacing section 1 of gore 1, restencil gore number and information data block on replacement section. For other gores, stencil gore numbers as necessary using procedures in WP 0048 00, MARKING AND STENCILLING. A gore section, which is damaged beyond repair, will be replaced as follows:

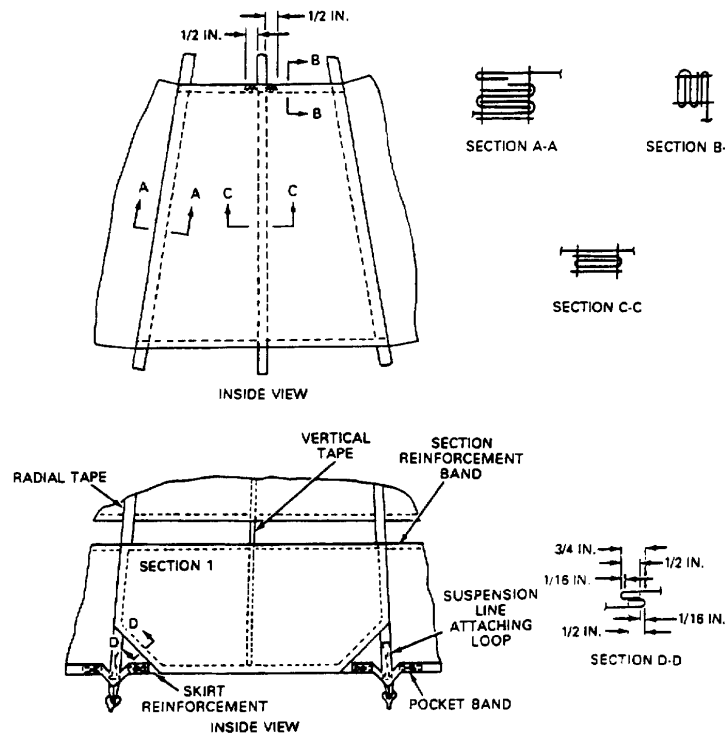

1. Invert canopy and locate damaged gore.
2. Remove items that may interfere with gore panel replacement by cutting the stitching; lay items aside.
3. Smooth out and secure surrounding canopy material to table with pushpins. Ensure adjacent lateral and radial seams are straight and damaged gore panel is not distorted.
4. Remove damaged gore panel by cutting material at a point  $\frac{1}{2}$ -inch in from adjacent webbing or edge.
5. Cut remaining material diagonally at each corner. Fold each raw edge back by  $\frac{1}{2}$ -inch. Pin and baste (WP 0046 00, SEWING PROCEDURES) to complete area preparation. Remove pins after basting.
6. Cut a piece of nylon cloth  $2\frac{1}{2}$ -inches longer and  $1\frac{1}{2}$ -inches wider than original gore section.
7. Place cut material over damaged area. Using a suitable marking device, trace outline or original gore section including width of radial webbing on each side of damaged area, width of lower lateral band, and edge reinforcement webbing. Allow material to extend 1-inch beyond original gore section upper edge,  $1\frac{1}{2}$ -inches below lower lateral band and edge reinforcement webbing, and  $\frac{3}{4}$ -inch beyond outside edge of radial webbing. Trim excess material, as required.
8. On upper end of cut material, make a double  $\frac{1}{2}$ -inch wide fold-under. Secure fold-under with a single row of stitching sewn through fold-under center across width of material. Stitching will be 7 to 11 stitches per inch.
9. Allow each side of replacement gore panel material to extend  $\frac{3}{4}$ -inch beyond outside edges of original gore section radial tapes. Ensure  $\frac{1}{2}$ -inch wide fold-under faces down. Temporarily secure replacement gore section to original gore section upper edge with pushpins.
10. On each side of replacement gore panel, make a  $\frac{3}{4}$ -inch wide fold-under and align material folded edge with outside edge of each of original gore section radial tapes. Temporarily secure each of side the fold-unders with pushpins.
11. At lower end of replacement gore section, make a doubled  $\frac{3}{4}$ -inch wide fold-under and align lower edge of fold with lower edge of lower lateral band. Temporarily secure fold-under with pushpins.
12. Baste edges of replacement gore section in accordance with WP 0046 00 and remove pushpins.
13. Using a light-duty sewing machine and size E, nylon thread, secure replacement gore section to original gore panel radial webbing, and lower lateral band with two rows of stitching, using 7 to 11 stitches per inch. Ensure lower edge of replacement gore panel does not extend beyond bottom of lower lateral band.
14. Remove basting. Re-invert canopy to outside.
15. Restore items removed in (2) above. Refer to applicable paragraph for detailed instruction.

**END OF WORK PACKAGE**

---

**DIRECT SUPPORT MAINTENANCE**  
**28-FOOT DIAMETER CARGO EXTRACTION PARACHUTE**  
**SUSPENSION LINE**

---

**THIS TASK COVERS:**

- Replace
- 

**Tools**

Aid, Splicing (Item 1, WP 0056 00)  
 Knife (Item 5, WP 0056 00)  
 Knife, Hot Metal (Item 6, WP 0056 00)  
 Sewing Machine, Zig-Zag (Item 23, WP 0056 00)  
 Yardstick (Item 26, WP 0056 00)

**Personnel Required**

92R (10) Parachute Rigger

**Equipment Condition**

Cleaned (WP 0008 00).  
 Inspected (WP 0009 00).  
 Unpacked, laid flat on repair table.

**Materials/Parts**

Marker, Felt-Tip, Black (Item 13, WP 0065 00)  
 Thread, Nylon, Size E (Item 30/31, WP 0065 00)  
 Thread, Nylon, Size FF (Item 32/33, WP 0065 00)  
 Thread, Nylon, Size 3 (Item 24/25, WP 0065 00)  
 Webbing, Nylon, Tubular, 3/4-IN., Natural (Item 38, WP 0065 00)

---

**REPLACE**

Replace a damaged suspension line by fabricating as follows:

**NOTE**

Two methods of stitching are used when replacing a damaged suspension line. The stitching used when performing this function will match those used in the original construction of the parachute.

1. Place the canopy in proper layout on a repair surface, apply partial tension to the suspension lines and trace the damaged suspension line from the connector link assembly to the suspension line attaching loop at the canopy skirt.
2. Remove the affected suspension line by cutting the loop formed on each end of the line length.
3. Sear one end of a length of 3/4-inch wide tubular nylon webbing.
4. Pass the seared webbing end through the applicable suspension line attaching loop, make an overhand knot and draw the knot snug. Allow sufficient length on the knotted webbing loose end for a 6-inch foldback. Temporarily secure the foldback.
5. Draw the webbing length toward the applicable suspension line connector link and apply tension on the webbing equal to that of the adjacent suspension line. Allowing sufficient length to apply an overhand knot and a 6-inch foldback on the connector link, cut and sear the webbing.
6. Pass the webbing end through the connector link, make an overhand knot and draw the knot snug. Temporarily secure the foldback.
7. Release suspension line tension and move the canopy assembly to a sewing machine table.

8. Secure the foldback located at the suspension line attachment loop by stitching a 4 1/2-inch long, three-point WW-stitch formation using a medium-duty sewing machine, 5 to 8 stitches per inch with size 3 nylon thread or two 6-inch rows of zig-zag stitches, 5/32-inch wide using a zig-zag sewing machine 7 to 11 stitches per inch and size FF nylon thread. Secure the foldback at the connector link by stitching a 4-inch long three-point WW stitch formation using a medium-duty sewing machine 5 to 8 stitches per inch with size 3 nylon thread or two 5 5/8-inch rows of zig-zag stitches, 5/32-inch wide using a zig-zag sewing machine 7 to 11 stitches per inch and size E nylon thread.

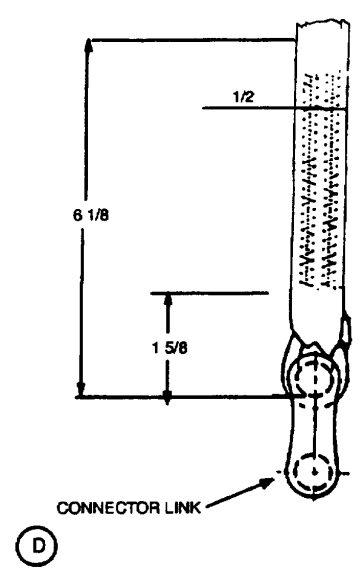
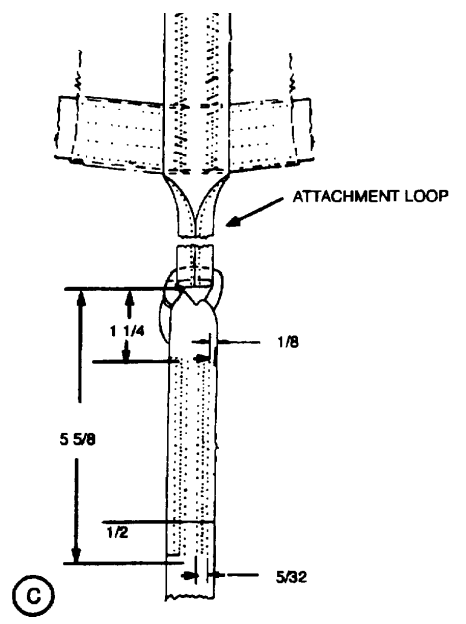
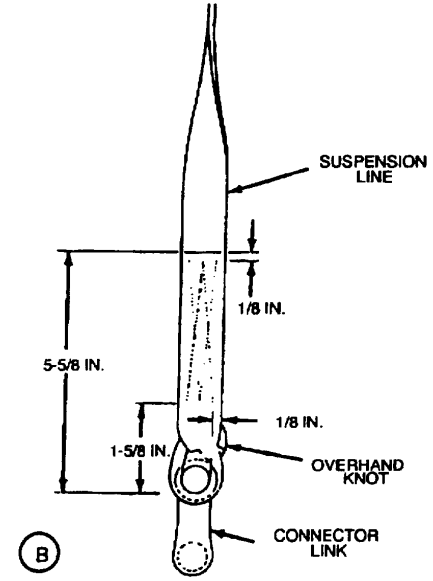
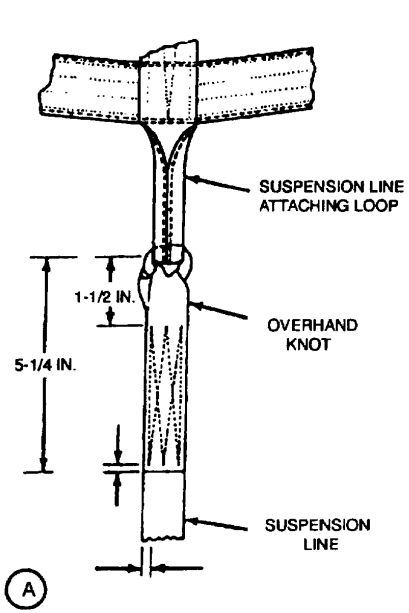

END OF WORK PACKAGE



---

**28-FOOT DIAMETER CARGO EXTRACTION PARACHUTE  
PREPARATION FOR STORAGE**

---

**THIS WORKPACKAGE COVERS:**

- Storage Criteria
  - General Storage Requirements
  - Storage Specifics for Parachutes
  - Contingency Parachute Stock (Non-Depot)
  - Contingency Parachute Stock (Depot)
  - Parachute Log Record
- 

**INITIAL SETUP:****Personnel Required**

92R(10) Parachute Rigger

**Equipment Condition**

Unpacked.

---

**STORAGE CRITERIA**

Administrative storage of the 28-Foot Cargo Extraction Parachute will be accomplished in accordance with AR 750-1, and the instructions furnished below.

**GENERAL STORAGE REQUIREMENTS**

To ensure that serviceability standards of the stored airdrop equipment are maintained, every effort will be exerted to adhere to the following general storage requirements:

1. When available, a heated building should be used to store parachutes.
2. Parachutes will be stored in a dry, well-ventilated location and protected from pilferage, dampness, fire, dirt, insects, rodents, and direct sunlight.
3. Parachutes will not be stored in a manner which would prevent ventilation or interfere with light fixtures, heating vents, fire fighting devices, cooling units, exits, or fire doors.
4. Parachutes will not be stored in a damaged, dirty, or damp condition.
5. All stored parachute items will be marked, segregated, and located for accessibility and easy identification.
6. Parachutes will not be stored in direct contact with any building floor or wall. Storage will be accomplished using bins, shelves, pallets, racks, or dunnage to provide airspace between the storage area floor and the equipment. If the pre-constructed shelving or similar storage accommodations are not available, locally fabricate storage provisions using suitable lumber or wooden boxes.
7. All available material handling equipment should be used as much as possible in the handling of parachutes.
8. Periodic rotation of stock, conversion of available space, proper housekeeping policies, and strict adherence to all safety regulations will be practiced at all times.

**STORAGE SPECIFICS FOR PARACHUTES**

In addition to the storage requirements stipulated in the general storage requirements paragraph, above, the following is a list of specifics that must be enforced when storing parachutes:

1. Except for those assemblies required for contingency operation, parachutes will not be stored in a packed configuration.

2. Stored parachute assemblies will be secured from access by unauthorized personnel.
3. A parachute that is in storage, and is administered a cyclic repack and inspection, will not be exposed to incandescent light or indirect sunlight for a period of more than 36-hours. In addition, exposure to direct sunlight will be avoided entirely.

**CONTINGENCY PARACHUTE STOCK (NON-DEPOT)**

Cargo and cargo extraction parachutes specifically identified as PACKED FOR CONTINGENCY and stored as contingency parachute stock separate from normal parachute stock will be repacked or replaced, and a not to exceed a 36-month interval, provided the storage conditions are in accordance with the following criteria:

1. Temperature is between 50°F and 95°F, with only occasional extremes from 40°F to 120°F.
2. Relative humidity is between 25 to 80%.
3. There are no rapid changes of temperature that would cause moisture condensation.
4. Equipment is stored at least 6-inches off the floor, 1-foot away from external walls and 4-feet below the roof or ceiling, with ventilation alleys between stacks on all sides.
5. Stock is protected by covers from exposure to bright sunlight (doors, windows, skylight) and from fluorescent lighting, if within 6-feet distance.
6. Measurements, inspection and records are maintained to show that the criteria are met.
7. Cargo and cargo extraction parachutes packed for non-depot contingency operations will be identified by an entry made on the JUMP, INSPECTION, AND REPACK DATA page of each applicable parachute log record. The statement PACKED FOR CONTINGENCY and the location of the contingency stock will be stamped in the log record using red ink.

JUMP, INSPECTION,				AND REPACK DATA				
DATE			BAG NUMBER	ROUTINE INSPECTION	REPACK	PACKER'S NAME	INSPECTOR'S NAME	UNIT
DAY	MO.	YR.						
21	10	01				Dhavel	Venkatesh	Sgt ARNDV
PACKED FOR CONTINGENCY -								
DATE RECEIVED								

**CONTINGENCY PARACHUTE STOCK (DEPOT)**

Cargo and cargo extraction parachutes specifically identified as PACKED FOR CONTINGENCY and stored as contingency parachute stock separate from normal parachute stock will be repacked or replaced at an interval not to exceed 144-months provided the storage conditions are in accordance with the following criteria:

1. Temperature is between 50°F and 95°F, with only occasional extremes from 40°F to 120°F.
2. Relative humidity is between 25 to 80%.

3. There are no rapid changes of temperature which would cause moisture condensation.
4. Equipment is stored at least 6-inches off the floor, 1-foot away from external walls and 4-feet below the roof or ceiling, with ventilation alleys between stacks on all sides.
5. Stock is protected by covers from exposure to bright sunlight (doors, windows, skylight) and from fluorescent lighting, if within 6-feet distance.
6. Measurements, inspection and records are maintained to show that the criteria are met.
7. Cargo and cargo extraction parachutes packed for contingency operations will be identified by an entry made on the JUMP, INSPECTION, AND REPACK DATA page of each applicable parachute log record. The statement PACKED FOR CONTINGENCY and the location of the contingency stock will be stamped in the log record using red ink.

JUMP, INSPECTION,				AND REPACK DATA				
DATE			BAG NUMBER	ROUTINE INSPECTION	REPACK	PACKER'S NAME	INSPECTOR'S NAME	UNIT
DAY	MO.	YR.						
21	10	01				Shavel	Vanekus	SGT ABENDIN
PACKED FOR CONTINGENCY -								
DATE RECEIVED								

**PARACHUTE LOG RECORD**

Using activities receiving cargo and cargo extraction parachutes from contingency stock will enter the date of receipt in each applicable parachute log record (refer to the illustration above). Subsequent repack intervals for these parachutes will be scheduled as specified above. However, under no circumstances will the repack interval exceed 36 months for non depot contingency stock parachutes. For depot contingency stock parachutes, the repack interval will not exceed 144-months.

**END OF WORK PACKAGE**

**THIS PAGE INTENTIONALLY LEFT BLANK**

---

**28-FOOT DIAMETER CARGO EXTRACTION PARACHUTE  
PREPARATION FOR SHIPMENT**

---

**THIS WORKPACKAGE COVERS:**

- In-Storage Inspection
  - Shipment
- 

**INITIAL SETUP:****Personnel Required**

92R(10) Parachute Rigger

**Equipment Condition**

Unpacked.

---

**IN-STORAGE INSPECTION**

**General Information.** An in-storage inspection is a physical check conducted on a random sample of airdrop equipment that is located in storage. Authorized rigger personnel (MOS 92R(20)) will conduct this inspection.

**Intervals.** Parachutes in storage will be inspected at least semiannually and at more frequent intervals if prescribed by the local parachute maintenance officer.

**Inspection.** Inspect to ensure that the parachute is ready for issue.

1. Check the parachute for proper identification.
2. Check that no damage or deterioration has been incurred.
3. Ensure that all modifications, or similar requirements, have been completed.
4. Check the adequacy of the storage facilities, efforts taken to control pests and rodents, and protection against unfavorable climatic conditions.

**SHIPMENT**

**Initial Shipment.** The initial packaging and shipping of parachutes are the responsibility of item manufacturers, who are required to comply with federal and military packing specifications, as stipulated in contractual agreements. Parachutes are normally shipped to depot activities, by domestic freight or parcel post, and packed to comply with overseas shipping requirements. Except for those parachute that are unpackaged and subjected to random inspections or testing by depot activity, parachutes received by a using unit will be contained in the original packaging materials.

**Shipping Between Maintenance Activities.** The shipping of parachutes between activities will be accomplished on a signature verification basis using whatever means of transportation is available. Used parachutes and other fabric items will be tagged in accordance with DA PAM 738-751, and rolled, folded, or placed loosely in a parachute pack, deployment bag, or other suitable container, as required. Unused parachutes will be transported in original shipping containers. During shipment, every effort will be made to protect parachute from weather elements, dust, dirt, oil, grease, and acids. Vehicles used to transport parachutes will be inspected to ensure the items are protected from the previously cited material damaging conditions.

**Other Shipping Instructions.** Parachutes destined for domestic or overseas shipment will be packaged and marked in accordance with AR 700-15, TM 38-230-1, and TM 38-230-2. Shipment of parachutes will be accomplished in accordance with TM 10-1670-201-23.

**ACCORDION FOLDING/RIGGER ROLLING**

**Accordion Folding.** Personnel parachute canopy assemblies that are not packed for use should be accordion folded prior to entry into storage. To accordion fold a parachute canopy assembly perform the following:

1. Place the parachute canopy in proper layout under partial tension and dress the outside edges of both gore groups.
2. Fold the left group of gores over the right group. Release the tension.

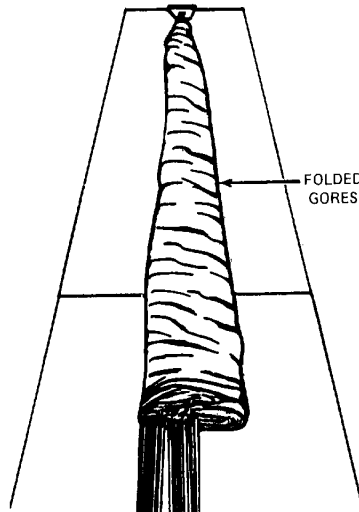

**FOLDING OF GORE GROUPS COMPLETED**

3. CHAIN the suspension lines and S-fold the chained lines on top of the applicable parachute pack.

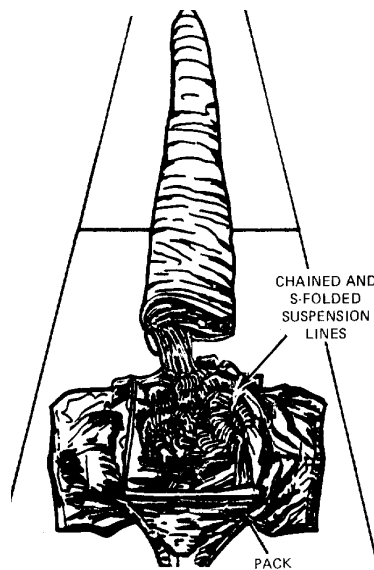

**SUSPENSION LINES STOWED ON PACK**

4. Place the lower end of the canopy on top of the S-folded suspension lines and locate the lower edge of the canopy skirt at the lower end of the pack.
5. Accordion fold the remaining canopy length neatly on top of the canopy lower end. Turn the canopy vent under the last fold.

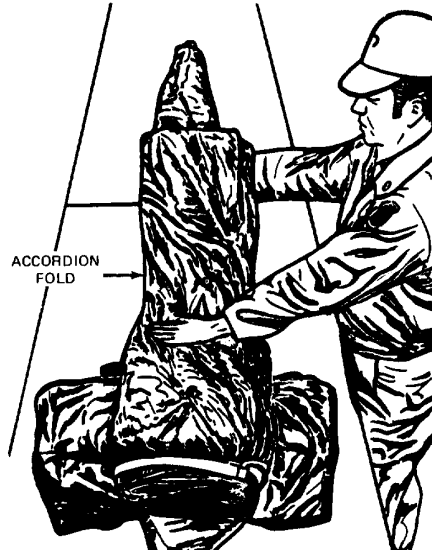

ACCORDION FOLDING THE CANOPY

6. Temporarily secure the folded canopy to the pack tray with available webbing or pack components.



FOLDED CANOPY SECURED

7. Upon completion of the accordion folding process, place the folded parachute assembly in a suitable type container for storage.

**Rigger Rolling.** Personnel parachute assemblies will be rigger rolled prior to being sent to, or returned from, a parachute repair activity, for ease of handling and to prevent suspension line entanglement. Rigger roll a parachute as follows:

1. Place the parachute in proper layout and apply partial tension.
2. Grasp the right and left suspension line groups. Using a fast circular motion, flip each of the two gore groups up and to the center radial seam. Tighten each gore group roll by hand; bring both rolled gore groups together at the center radial seam.

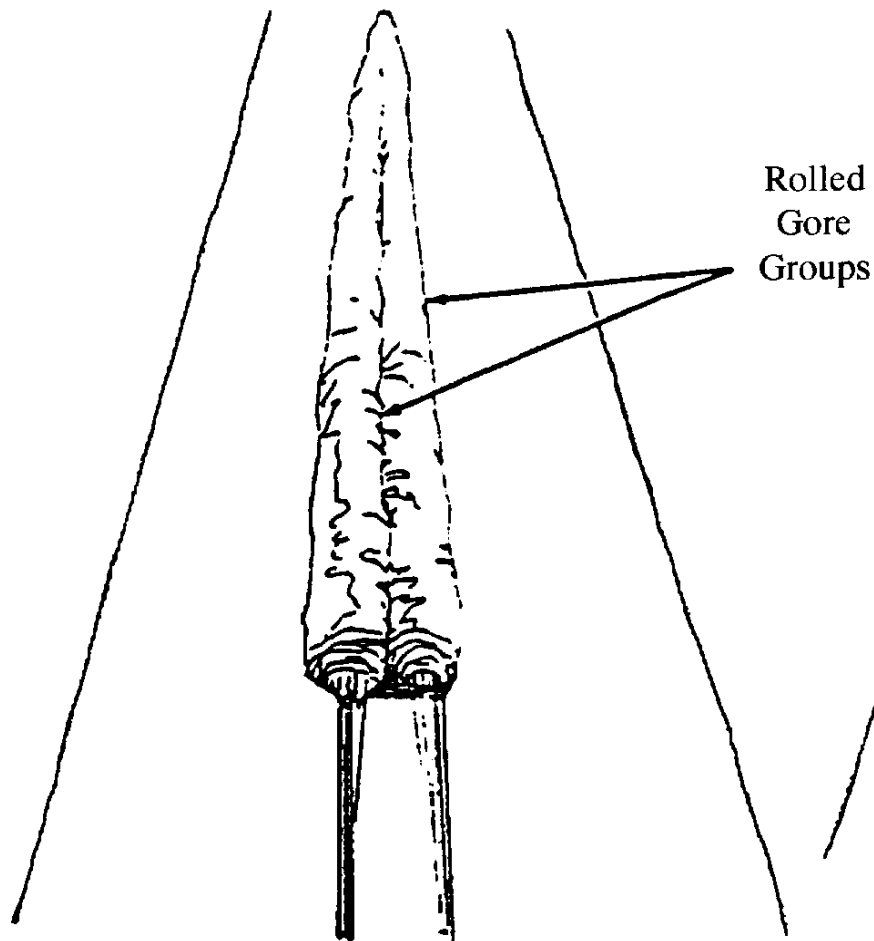

3. Release tension and disconnect the canopy vent from the vent-attaching device.
4. Fold the canopy vent down between the rolled gore groups to a point within 18-inches of the canopy skirt lower edge.



5. Beginning at the folded upper end of the canopy, roll the canopy tightly toward the canopy skirt. Ensure the width of the rolled canopy does not exceed the width of the applicable parachute pack tray.

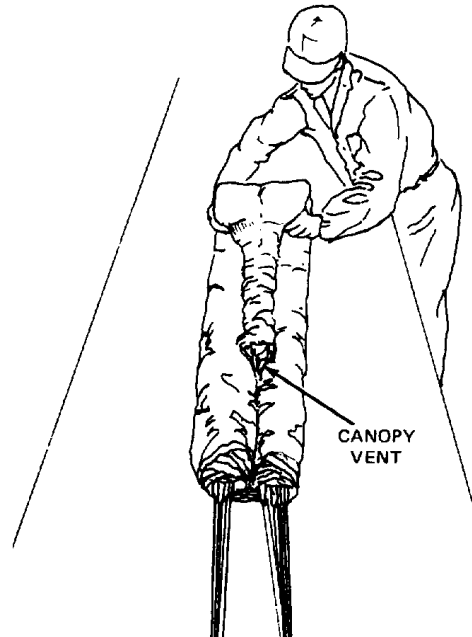

6. Continue rolling the canopy toward the lower end of the suspension lines and risers. If applicable, locate the lines and riser webbing around the center of the roll.

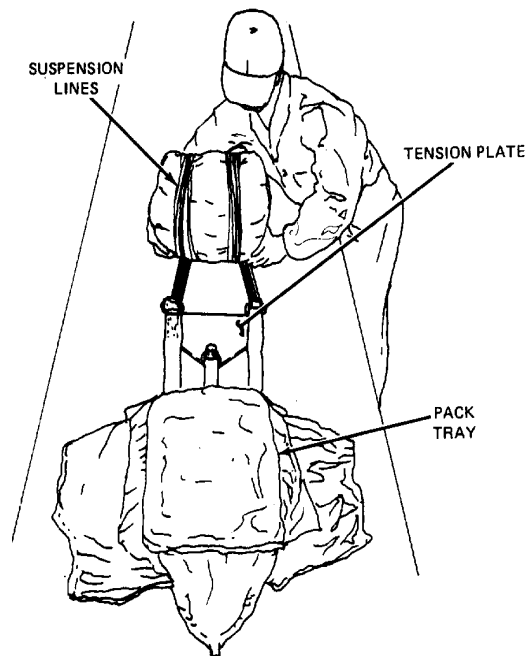

7. As applicable, disconnect the suspension lines/risers from the attaching device and place the rolled canopy assembly on top of the pack tray.
8. Secure the rolled canopy assembly within the confines of the pack tray, using either the straps or webbing of the pack tray, or a length of suitable type cord.

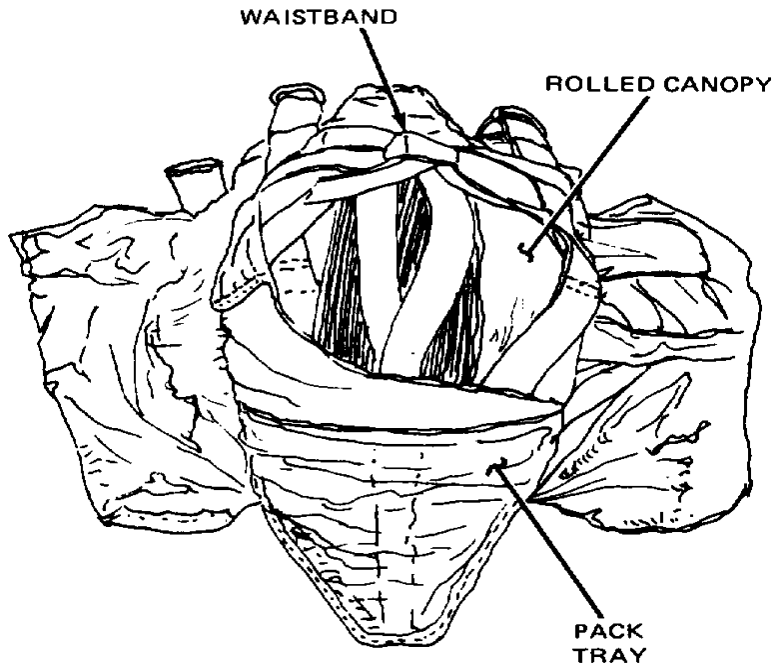

**END OF WORK PACKAGE**

**CHAPTER 5**

**SUPPORTING INFORMATION  
FOR  
PARACHUTE, CARGO TYPE:  
28-FOOT DIAMETER, CARGO  
EXTRACTION PARACHUTE**

**THIS PAGE INTENTIONALLY LEFT BLANK**

---

**SUPPORTING INFORMATION**  
**28-FOOT DIAMETER CARGO EXTRACTION PARACHUTE**  
**REFERENCES**

---

**THIS WORKPACKAGE COVERS:**

- Scope
  - Publication Indexes
  - Pamphlets
  - Technical Manuals
  - Field Manuals
  - Army Regulations
  - Technical Bulletins
- Forms
  - Air Force Technical Orders
  - Air Force Technical Order Forms
  - Marine Corps Forms
- 

**SCOPE**

This appendix lists all forms, technical manuals, and miscellaneous publications referenced in this manual.

**PUBLICATION INDEXES**

The following publication indexes should be consulted frequently for the latest changes or revisions of references given in this work package, and for new publications relating to the material covered in this manual:

**PAMPHLETS**

Consolidated Index of Army Publications and Blank Forms	DA PAM 25-30
Functional Users Manual for The Army Maintenance Management System (TAMMS)	DA PAM 738-750
Functional Users Manual for The Army Maintenance Management System (Aviation) (TAMMSA)	DA PAM 738-751

**TECHNICAL MANUALS**

General Maintenance of Parachutes and Other Airdrop Equipment	TM 10-1670-201-23/ T.O. 13C-1-41/ NAVAIR 13-1-17
Ancillary Equipment For Low Velocity Air Drop System (LVADS)	TM 10-1670-296-20&P/T.O. 13C7-49-2
Preservation, Packaging, Packing of Military Supplies and Equipment (Vols. 1 and 2)	TM 38-230-1 and TM 38-230-2
Equipment Maintenance Forms and Procedures	TM 4700-15/1
Procedures for the Destruction of Air Delivery Equipment to Prevent Enemy Use	TM 43-0002-1/ T.O. 13C3-1-10/ NAVAIR 13-1-19

**FIELD MANUALS**

Airdrop of Supplies and Equipment: Information Rigging Airdrop Platform	FM 4.20.120 (FM 10-500-2)
First Aid for Soldiers	FM 4-25.11 (FM 21-11)

**ARMY REGULATIONS**

Dictionary of United States Army Terms	AR 310-25
Authorized Abbreviation and Brevity Codes and Acronyms	AR 310-50
Packaging of Material	AR 700-15
Army Material Maintenance Concepts and Policies	AR 750-1
Air Drop, Parachute Recovery and Aircraft Personal Escape Systems	AR 750-32
Reporting of Item and Packaging Discrepancies	AR 735-11-2
Reporting of Transportation Discrepancies in Shipments	AR 55-38

**TECHNICAL BULLETINS**

Maintenance Expenditure Limits for FSC Group 16, FSC Class 1670	TB 43-0002-43
-----------------------------------------------------------------	---------------

**FORMS**

Parachute Log Record	DA Form 3912
Equipment Inspection & Maintenance Worksheet	DA Form 2404
Report of Discrepancy	SF 364
Transportation Discrepancy Report	SF 361
Product Quality Deficiency Report	SF 368

**AIR FORCE TECHNICAL ORDERS**

Cleaning of Parachute Assemblies	T.O. 14D1-1-2
Parachute Logs and Records	T.O. DO-25-241

**AIR FORCE TECHNICAL ORDER FORMS**

Parachute Log	AFTO 391
Parachute Repack Inspection and Component Card	AFTO 392

**MARINE CORPS FORMS**

Marine Corps Military Incentive Awards Program	MCO 1650.17F
Parachute History Record	NAV WPN CEN or NAV WPNS CL 13512/11
Product Quality Deficiency Report (PQDR)	MCO 4855.10B
Recommended Changes to Technical Publications	NAVMC 10772

**END OF WORK PACKAGE**

**THIS PAGE INTENTIONALLY LEFT BLANK**



---

**SUPPORTING INFORMATION**  
**28-FOOT DIAMETER CARGO EXTRACTION PARACHUTE**  
**MAINTENANCE ALLOCATION CHART (MAC)**

---

**THIS WORKPACKAGE COVERS:**

- Introduction
  - Maintenance Functions
  - Explanation of Columns in the MAC
  - Explanation of Columns in Tool and Test Equipment Requirements
  - Explanation of Column in Remarks
- 

**INTRODUCTION****The Army Maintenance System MAC**

This section provides a general explanation of all maintenance and repair functions authorized at various maintenance levels under the standard Army Maintenance System concept.

The Maintenance Allocation Chart (MAC) designates overall authority and responsibility for the performance of maintenance functions on the identified end item or component. The application of the maintenance functions to the end item or component will be consistent with the capacities and capabilities of the designated maintenance levels, which are shown in the MAC in column (4) as:

- Unit – includes two sub-columns, C (operator/crew) and O (unit) maintenance
- Direct Support – includes an F sub-column
- General Support – includes an H sub-column
- Depot – includes a sub-column

The tools and test equipment requirements (immediately following the MAC) list the tools and test equipment (both special tools and common tool sets) required for each maintenance function as referenced from the MAC.

The remarks (immediately following the tools and test equipment requirements) contain supplemental instructions and explanatory notes for a particular maintenance function.

**MAINTENANCE FUNCTIONS**

Maintenance functions will be limited to, and defined, as follows:

**Inspect.** To determine the serviceability of an item by comparing its physical, mechanical, and/or electrical characteristics with established standards through examination (e.g. by sight, sound, feel, etc.).

**Test.** To verify serviceability by measuring the mechanical, pneumatic, hydraulic, or electrical characteristics of an item and comparing those characteristics with prescribed standards.

**Service.** Operations, periodically required, to keep an item in proper operating condition, i.e., to clean (includes decontaminate, when required), to preserve, to drain, to paint, or to replenish fuel, lubricants, chemical fluids, or gases.

**Adjust.** To maintain or regulate, within prescribed limits, by bringing into proper or exact position, or by setting the operating characteristics to specified parameters.

**Align.** To adjust specified variable elements of an item to bring about optimum or desired performance.

**Calibrate.** To determine and cause corrections to be made or to be adjusted on instruments or test, measuring, and diagnostic equipments used in precision measurement. Consists of comparisons of two instruments, one of which is a certified standard of known accuracy, to detect and adjust any discrepancy in the accuracy of the instrument being compared.

**Remove/Install.** To remove and install the same item when required to perform service or other maintenance functions. Install may be the act of emplacing, seating, or fixing into position a spare, repair part, or module (component or assembly) in a manner to allow the proper functioning of an equipment or system.

**Replace.** To remove an unserviceable item and install a serviceable counterpart in its place. Replace is authorized by the MAC, and is shown as the 3<sup>rd</sup> position code of the Source, Maintenance, and Recoverability (SMR) code.

**Repair.** The application of maintenance services, including fault location/troubleshooting, removal/installation, and disassembly/assembly procedures, and maintenance actions to identify troubles and restore serviceability to an item by correcting specific damage, fault, malfunction, or failure in a part, subassembly, module (component or assembly), end item, or system.

**Overhaul.** The maintenance effort (service/action) prescribed to restore an item to a completely serviceable/operations condition, as required by maintenance standards in appropriate technical publications (i.e., DMWR). Overhaul is normally the highest degree of maintenance performed by the Army. Overhaul does not normally return an item to like new condition.

**Rebuild.** Consists of those services/actions necessary for the restoration of unserviceable equipment to a like new condition, in accordance with original manufacturing standards. Rebuild is the highest degree of materiel maintenance applied to Army equipment. The rebuild operation includes the act of returning to zero those age measurements (hours, miles, etc.) considered in classifying Army equipment/components.

#### **EXPLANATION OF COLUMNS IN THE MAC, TABLE 1**

**Column 1, Group Number.** Column 1 lists functional group code numbers, the purpose of which is to identify maintenance significant components, assemblies, subassemblies, and modules with the next higher assembly. End item group number shall be listed as 00.

**Column 2, Component/Assembly.** Column 2 contains the names of the components, assemblies, subassemblies, and modules for which maintenance is authorized.

**Column 3, Maintenance Function.** Column 3 lists the functions to be performed on the item listed in Column 2. (For detailed explanation of these functions, see the Maintenance Functions information detailed above.)

**Column 4, Maintenance Level.** Column 4 specifies, by the listing of work-time in the appropriate sub column(s), the level of maintenance authorized to perform the function listed in Column 3. This figure represents the active time required to perform that maintenance function at the indicated level of maintenance. If the number of complexity of the tasks within the listed maintenance function varies at different maintenance levels, appropriate work-time figures will be shown for each level. The work-time figure represents the average time required to restore an item (assembly, subassembly, component, module, end item, or system) to a serviceable condition under typical field operating conditions.

This time includes preparation time (including any necessary disassembly/assembly time), troubleshooting/fault location time, and quality assurance/quality control time, in addition to the time required to perform the specific tasks identified for the maintenance functions authorized in the maintenance allocation chart. The symbol designations for the various maintenance levels are as follows:

- C - Operator or Crew
- O - Unit Maintenance
- F - Direct Support Maintenance
- H - General Support Maintenance
- D - Depot Maintenance

**Column 5, Tools and Equipment.** Column 5 specifies by code, those common tool sets (not individual tools) and special tools (Test, Measurement, and Diagnostic Equipment (TMDE)), and support equipment required to perform the designated function.

**Column 6, Remarks.** This column shall, when applicable, contain a letter code, in alphabetical order, which shall be keyed to remarks contained in Table 3.

**EXPLANATION OF COLUMNS IN TOOL AND TEST EQUIPMENT REQUIREMENTS, TABLE 2**

**Column 1, Reference Code.** The tool and test equipment reference code correlates with a code used in the MAC, Table 1, Column 5.

**Column 2, Maintenance Category.** The lowest category of maintenance authorized to use the tool or test equipment.

**Column 3, Nomenclature.** Name or identification of the tool or test equipment.

**Column 4, National Stock Number.** The National stock number of the tool or test equipment.

**Column 5, Tool Number.** The manufacturer's part number.

**EXPLANATION OF COLUMN IN REMARKS, TABLE 3**

**Column 1, Reference Code.** The code recorded in column 6, Table 1.

**Column 2, Remarks.** This column lists information pertinent to the maintenance function being performed as indicated in the MAC.

**Table 1. Maintenance Allocation Chart For 28-Foot Diameter, Cargo Extraction Parachute**

(1) GROUP NUMBER	(2) COMPONENT/ASSEMBLY	(3) MAINTENANCE FUNCTION	(4) MAINTENANCE LEVEL					(5) TOOLS AND EQUIPMENT	(6) REMARKS
			UNIT		INTERMEDIATE		DEPOT		
			C	O	F	H	D		
01	Canopy	Inspect Service Repair		0.8 1.0 0.4					A, B, C, D
0101	Vent Line	Repair Replace		0.5	0.1				
0102	Bridle Centering Line	Repair Replace		0.3	0.5				
0103	Upper Lateral Band	Repair		0.3					
0104	Gore Section	Repair Replace		0.4	0.8				D
0105	Radial Tape	Repair		0.4					
0106	Vertical Tape	Repair		0.4					
0107	Panel Edge Reinforcement	Repair		0.4					

**Table 1. Maintenance Allocation Chart For  
28-Foot Diameter, Cargo Extraction Parachute - Continued**

(1) GROUP NUMBER	(2) COMPONENT/ASSEMBLY	(3) MAINTENANCE FUNCTION	(4) MAINTENANCE LEVEL					(5) TOOLS AND EQUIPMENT	(6) REMARKS
			UNIT		INTERMEDIATE		DEPOT		
			C	O	F	H	D		
0108	Lower Lateral Band	Repair		0.5					
0109	Pocket Band	Repair Replace		0.3 0.4					
0110	Suspension Line Attachment Loop	Repair Replace		0.1 0.5					
0111	Suspension Line	Repair Replace		0.3	0.6				
0112	Suspension Line Keeper	Repair Replace		0.3 0.4					
0113	Connector Link	Repair Replace		0.1 0.1					
02	Adapter Web	Inspect Service Repair Replace		0.1 0.1 0.1 0.1					A, B, E
0201	Web Body	Repair		0.1					
0202	Long Buffer	Repair Replace		0.1 0.1					
0203	Short Buffer	Repair Replace		0.1 0.1					
0204	Fixed Keeper	Repair Replace		0.1 0.3					
03	Deployment Bag	Inspect Service Repair Replace		0.3 0.1 0.4 0.1					
0301	Grommet	Repair Replace		0.1 0.2					
0302	Retainer Band Keeper	Repair Replace		0.2 0.4					
0303	Retainer Band Keeper Reinforcement	Repair Replace		0.2 0.3					
0304	Tie Loop	Repair Replace		0.2 0.3					
0305	Tie Loop Reinforcement	Repair Replace		0.2 0.3					
0306	Pendulum Line	Replace		0.2					
0307	Log Record Book Pocket	Repair Replace		0.1 0.2					
0308	Safety Cord	Repair Replace		0.2 0.4					
0309	Bag Closing Loop	Repair Replace		0.2 0.4					

**Table 1. Maintenance Allocation Chart For  
28-Foot Diameter, Cargo Extraction Parachute - Continued**

0310	Bag Retainer Line	Repair Replace		0.2 0.5					
0311	Edge Binding	Repair		0.3					
0312	Deployment Bag Panels and Flaps	Repair		0.4					
0313	Stowage Flap Edge Reinforcement	Repair		0.4					

**Table 2. Tool and Test Equipment Requirements for the 28-Foot  
Diameter, Cargo Extraction Parachute**

(1) TOOL or TEST EQUIPMENT REFERENCE CODE	(2) MAINTENANCE CATEGORY	(3) NOMENCLATURE	(4) NATIONAL NATO STOCK NUMBER	(5) PN TOOL NUMBER
1	O	Aid, Splicing	WP 0066 00	
2	O	Brush, Scrub, Household	7920-00-282-2490	H-B-1490
3	O	Brush, Stenciling	7520-00-248-9285	H-B-621
4	O	File, Flat	5110-00-249-2848	GGG-F-325
5	O	Knife	5110-00-162-2205	MIL-K-818C
6	O	Knife, Hot Metal	3439-01-197-7656	4025
7	O	Lead, Pig, 5-pounds	9650-00-264-5050	QQ-C-40
8	O	Machine, Stencil Cutting	7490-00-164-0537	A-A-2722
9	O	Mallet, Rawhide	5120-00-293-3397	GGG-H-33
10	O	Needle, Tacking	8315-00-262-3733	FF-N-180
11	O	Paddle, Packing	1670-00-764-6381	11-1-152
12	O	Pliers, Lineman	5120-00-756-1156	GGG-P-471
13	O	Pot, Melting, Electric	5120-00-924-5213	L-115
14	O	Screwdriver, Cross-Tip	5120-00-234-8913	BD122
15	O	Screwdriver, Flat Tip	5120-00-293-0314	GGG-S-121
16	O	Separator, Line	1670-00-092-8661	11-1-17-1
17	O	Separator, Link	1670-00-072-4941	MIL-S-43243
18	O	Set, Chuck and Die	5120-00-694-5153	7540756
19	O	Sewing Machine, Darning	Table 2, WP 0012 00	
20	O	Sewing Machine, Heavy-Duty	Table 2, WP 0012 00	
21	O	Sewing Machine, Light-Duty	Table 2, WP 0012 00	

**Table 2. Tool and Test Equipment Requirements for the 28-Foot Diameter, Cargo Extraction Parachute - Continued**

(1) TOOL or TEST EQUIPMENT REFERENCE CODE	(2) MAINTENANCE CATEGORY	(3) NOMENCLATURE	(4) NATIONAL NATO STOCK NUMBER	(5) PN TOOL NUMBER
22	O	Sewing Machine, Medium-Duty	Table 2, WP 0012 00	
23	O	Sewing Machine, Zig-Zag	Table 2, WP 0012 00	
24	O	Shears	5110-00-223-6370	GGG-S-278
25	O	Weight, Packing	1670-00-375-9134	66C38599
26	O	Yardstick	5120-00-985-6610	GGG-Y-0035

**Table 3. Remarks for the 28-Foot Diameter, Cargo Extraction Parachute**

REFERENCE CODE	REMARKS/NOTES
A	Inspect is a technical-rigger type inspection.
B	Service is to clean the equipment.
C	Service is the packing of parachutes.
D	Repair at unit maintenance consists of darning, restitching, patching and replacement of parts authorized for unit maintenance. Direct support repair consists of replacing gore sections.
E	Repair by darning, retacking, restitching splice edge binding and repairing grommets. Replacement of parts authorized for unit maintenance.

**END OF WORK PACKAGE**

**SUPPORTING INFORMATION  
28-FOOT DIAMETER CARGO EXTRACTION PARACHUTE  
REPAIR PARTS AND SPECIAL TOOLS LIST, INTRODUCTION**

**SCOPE**

This manual lists and authorizes spare and repair parts; special tools; special test, measurement, and diagnostic equipment (TMDE); and other special support equipment required for performance of organizational, direct support, and general support maintenance of the 28-Foot Diameter, Cargo Extraction Parachute. It authorizes the requisitioning, issue, and disposition of spares, repair parts and special tools, as indicated by the Source, Maintenance and Recoverability (SMR) codes.

**GENERAL**

In addition to the Introduction work package, this RPSTL is divided into the following work packages:

**Repair Parts List Work Packages.** Work packages containing lists of spares and repair parts authorized by this RPSTL for use in the performance of maintenance. These work packages also include parts which must be removed for replacement of the authorized parts. Parts lists are composed of functional groups in ascending alphanumeric sequence, with the parts in each group listed in ascending figure, and item number sequence. Sending units, brackets, filters, and bolts are listed with the component they mount on. Bulk materials are listed by item name in FIG. BULK at the end of the work packages. Repair parts kits are listed separately in their own functional group and work package. Repair parts for reparable special tools are also listed in a separate work package. Items listed are shown on the associated illustrations.

**Special Tools List Work Packages.** Work packages containing lists of special tools, special TMDE, and special support equipment authorized by this RPSTL (as indicated by Basis of Issue (BOI) information in the DESCRIPTION AND USABLE ON CODE (UOC) column.) Tools that are components of common tool sets and/or Class VII are not listed.

**Cross Reference Indexes Work Packages.** There are two cross-reference indexes work packages in this RPSTL: the National Stock Number (NSN) Index work package, and the Pat Number (P/N) Index work package. The National Stock Number Index work package refers you to the figure and item number. The Pat Number Index work package refers you to the figure and item number.

**EXPLANATION OF COLUMNS**

**Column 1, Item No.** Indicates the number used to identify items called out in the illustration.

**Column 2, SMR Code.** The Source, Maintenance, and Recoverability (SMR) code is a 5-position code containing supply/requisitioning information, maintenance category authorization criteria, and disposition instructions, as shown in the following breakout:

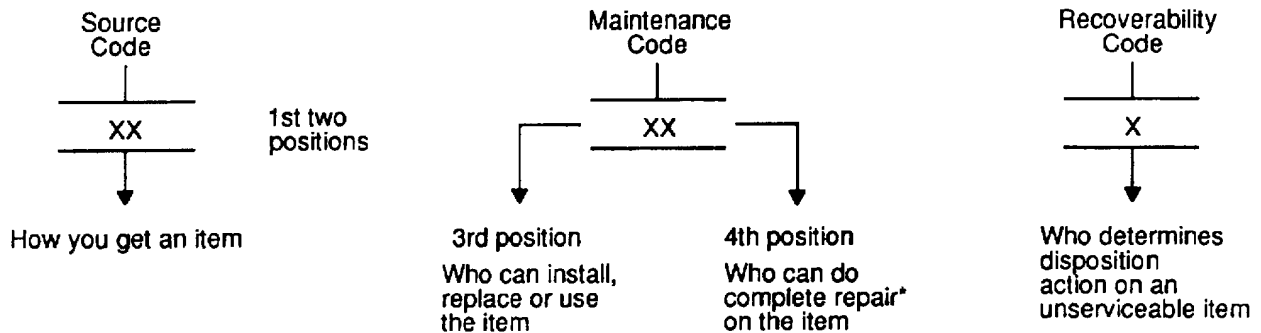

\*Complete Repair: Maintenance capacity, capability, and authority to perform all the corrective maintenance tasks of the REPAIR function in a use/user environment in order to restore serviceability to a failed item.

**Source Code.** The source code tells you how to get an item needed for maintenance, repair, or overhaul of an end item/equipment. Source codes are always the first and second positions of the SMR code. Explanations of source codes follow:

SOURCE CODE	EXPLANATION
PA	Stock items; use the applicable NSN to requisition/request items with these source codes. They are authorized to the level indicated by the code entered in the 3 <sup>rd</sup> position of the SMR code.
PB	
PC	
PD	
PE	
PF	
PG	
	<b>NOTE</b>
	Items coded PC are subject to deterioration.
	Items with these codes are not to be requested/requisitioned individually. They are part of a kit which is authorized to the maintenance level indicated in the 3 <sup>rd</sup> position of the SMR code. The complete kit must be requisitioned and applied.
	Items with these codes are not to be requisitioned/requested individually. They must be made from bulk material which is identified by the P/N in the DESCRIPTION and USABLE ON CODE (UOC) column and listed in the bulk material group work package of the RPSTL. If the item is authorized to you by the 3 <sup>rd</sup> position code of the SMR code, but the source code indicates it is made at a higher level, order the item from the higher level of maintenance.
MO – (Made at unit/AVUM Level)	
MF – (Made at DS/AVIM Level)	
MH – (Made at GS Level)	
ML – (Made at SRA)	
MD – (Made at Depot)	
	Items with these codes are not to be requested/requisitioned individually. The parts that make up the assembled item must be requisitioned or fabricated and assembled at the level of maintenance indicated by the source code. If the 3 <sup>rd</sup> position code of the SMR code authorizes you to replace the item, but the source code indicates the item is assembled at a higher level, order the item from the higher level of maintenance.
AO – (Assembled by unit AVUM Level)	
AF – (Assembled by DS/AVIM Level)	
AH – (Assembled by GS Level)	
AL – (Assembled by SRA)	
AD – (Assembled by Depot)	
XA -	Do not requisition an XA-coded item. Order the next higher assembly. (Refer to the NOTE below.)
XB -	If an item is not available from salvage, order it using the CAGEC and P/N.



**SOURCE CODE – continued**

**EXPLANATION - continued**

XC -	Installation drawings, diagrams, instruction sheets, field service drawings; identified by manufacturer's P/N.
XD -	Item is not stocked. Order an XD-coded item through normal supply channels using the CAGEC and P/N given, if no NSN is available.

NOTE

Cannibalization or controlled exchanged, when authorized, may be used as a source of supply for items with the above source codes, except for those source coded XA or those aircraft support items restricted by requirements of AR 750-1.

**Maintenance Code.** Maintenance codes tell you the level(s) of maintenance authorized to use and repair support items. The maintenance codes are entered in the third and fourth positions of the SMR Code as follow:

**Third position.** The maintenance code entered in the third position tells you the lowest maintenance level authorized to remove, replace, and use an item. The maintenance code entered in the third position will indicate authorization to one of the following levels of maintenance.

**MAINTENANCE CODE**

**APPLICATION/EXPLANATION**

C -	Crew or operator maintenance done within unit/AVUM maintenance.
O -	Unit level/AVUM maintenance can remove, replace, and use the item.
F -	Direct support/ AVIM maintenance can remove, replace, and use the item.
H -	General support maintenance can remove, replace, and use the item.
L -	Specialized repair activity can remove, replace, and use the item.
D -	Depot can remove, replace, and use the item.

**Fourth position.** The maintenance code entered in the fourth position tells you whether or not the item is to be repaired and identifies the lowest maintenance level with the capability to do complete repair (perform all authorized repair functions).

NOTE

Some limited repair may be done on the item at a lower level of maintenance, if authorized by the Maintenance Allocation Chart (MAC) and SMR code.

MAINTENANCE CODE	APPLICATION/ EXPLANATION
O -	Unit/AVUM is the lowest level that can do complete repair of the item.
F -	Direct support/AVIM is the lowest level that can do complete repair of the item.
H -	General support is the lowest level that can do complete repair of the item.
L -	Specialized repair activity (designate the specialized repair activity) is the lowest level that can do complete repair of the item.
D -	Depot is the lowest level that can do complete repair of the item.
Z -	Non-repairable. No repair is authorized.
B -	No repair is authorized. No parts or special tools are authorized for the maintenance of a B-coded item. However, the item may be reconditioned by adjusting, lubricating, etc., at the user level.

**Recoverability code.** Recoverability codes are assigned to items to indicate the disposition action on unserviceable items. The recoverability code is entered in the **fifth position** of the SMR code as follows:

RECOVERABILITY CODE	APPLICATION/EXPLANATION
Z -	Non-repairable item. When unserviceable, condemn and dispose of the item at the level of maintenance shown in the third position of the SMR Code.

**RECOVERABILITY CODE – continued**

**APPLICATION/EXPLANATION - continued**

O -	Repairable item. When uneconomically repairable, condemn and dispose of the item at the unit level.
F -	Repairable item. When uneconomically repairable, condemn and dispose of the item at the direct support level.
H -	Repairable item. When uneconomically repairable, condemn and dispose of the item at the general support level.
D -	Repairable item. When beyond the lower level repair capability, return to depot. Condemnation and disposal of item not authorized below depot level.
L -	Repairable item. Condemnation and disposal not authorized below Specialized Repair Activity (SRA).
A -	Item requires special handling or condemnation procedures because of specific reasons (such as, precious metal content, high dollar value, critical material or hazardous material). Refer to appropriate manuals/directives for specific instructions.

**Column 3, NSN.** The NSN for the item is listed in this column.

**Column 4, CAGEC.** The Commercial and Government Entity Code (CAGEC) is a five-digit numeric code that is used to identify the manufacturer, distributor, or Government agency that supplies the item.

**Column 5, Part Number.** Indicates the primary number used by the manufacturer (individual, company, firm, corporation, or Government activity), which controls the design and characteristics of the item by means of its engineering drawings, specifications, standards, and inspection requirements to identify an item or range of items.

NOTE

When you use an NSN to requisition an item, the item you receive may have a different P/N from the part ordered.

**Column 6, Description and Usable on Code (UOC).** This column includes the following information:

1. The federal item name and, when repaired, a minimum description to identify the item.
2. P/Ns for bulk materials are referenced in this column in the line entry for the to be manufactured or fabricated.
3. Hardness Critical Item (HCI). A support item that provides the equipment with special protection from electromagnetic pulse (EMP) damage during a nuclear attack.
4. The statement END OF FIGURE appears just below the last item description in column (6) for a given figure in both the repair parts list and special tools list work packages.

**Column 7, QTY.** The QTY (quantity per figure) column indicates the quantity of the item used in the breakout shown on the illustration/figure, which is prepared for a functional group, sub-functional group, or an assembly. A “V” appearing in the column instead of a quantity indicates that the quantity is variable and quantity may change from application to application.

**EXPLANATION OF COLUMNS**

**1. National Stock Number (NSN) Index Work Package.**

STOCK NUMBER Column. This column lists the NSN by National Item Identification Number (NIIN) sequence. The NIIN consists of the last nine digits of the NSN, i.e.

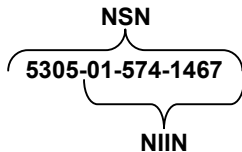

When using this column to locate an item, ignore the first 4 digits of the NSN. However, the complete NSN should be used when ordering items by stock number.

FIG. column. This column lists the number of the figure where the item is identified/located. The figures are in numerical order in the repair parts list and special tools list work packages.

ITEM column. The item number identifies the item associated with the figure listed in the adjacent FIG. column. This item is also identified by the NSN listed on the same line.

**2. Part Number (P/N) Index Work Package.**

P/Ns in this index are listed in ascending alphanumeric sequence (vertical arrangement of letter and number combinations which places the first letter or digit of each group in order A through Z, followed by the numbers 0 through 9 and each following letter or digit in like order).

PART NUMBER Column. Indicates the P/N assigned to the item.

FIG. Column. This column lists the number of the figure where the item is identified/located in the repair parts list and special tools list work packages.

ITEM Column. The item number is the number assigned to the item as it appears in the figure referenced in the adjacent figure number column.

### SPECIAL INFORMATION

The Usable on Code title appears in the lower right corner of column (5), Description. Usable on codes are shown in the right-hand margin of the description column. Identification of the usable on codes used in the RPSTL are:

Code:	Used on:
DWX	1670-00-040-8135

*NOTE: Include the above UOC content, as applicable.*

Fabrication Instructions. Bulk materials required to manufacture items are listed in the bulk material functional group of this RPSTL. Part numbers for bulk material are also referenced in the Description Column of the line item entry for the item to be manufactured/fabricated. Detailed fabrication instructions for items source coded to be manufactured or fabricated are found in this TM.

Index Numbers. Items which have the word BULK in the figure column will have an index number shown in the item number column. This index number is a cross-reference between the NSN / P/N index work packages and the bulk material list in the repair parts list work package.

*NOTE: The following paragraph shall appear only in the unit maintenance RPSTL special instructions.*

Illustration List. The illustrations in this RPSTL contain unit authorized items. Illustrations published in this TM that contain unit authorized items also appear in this RPSTL. The tabular list in the repair parts list work package contains only those parts coded "O" in the third position of the SMR code, therefore, there may be a break in the item number sequence.

### HOW TO LOCATE REPAIR PARTS

#### 1. When National Stock Number or Part Number is Not Known.

First. Using the table of contents, determine the assembly group or sub-functional group to which the item belongs. This is necessary since the figures are prepared for functional groups and sub-assembly groups, and lists are divided into the same groups.

Second. Find the item covering the figure covering the functional group or sub-functional group to which the item belongs.

Third. Identify the item on the figure and note the number(s).

Fourth. Look in the repair parts list work packages for the figure and item numbers. The NSNs and part numbers are on the same line as the associated item numbers.

#### 2. When NSN is Known.

First. If you have the NSN, look in the STOCK NUMBER column of the NSN index work package. The NSN is arranged in NIIN sequence. Note the figure and item number next to the NSN.

Second. Turn to the figure and locate the item number. Verify that the it is the one you are looking for.

**3. When P/N is Known.**

First. If you have the P/N and not the NSN, look in the PART NUMBER column of the P/N index work package. Identify the figure and item number.

Second. Look up the item on the figure in the applicable repair parts list work package.

**END OF WORK PACKAGE**

**THIS PAGE INTENTIONALLY LEFT BLANK**

GROUP 01 28-FOOT DIAMETER, CARGO EXTRACTION PARACHUTE

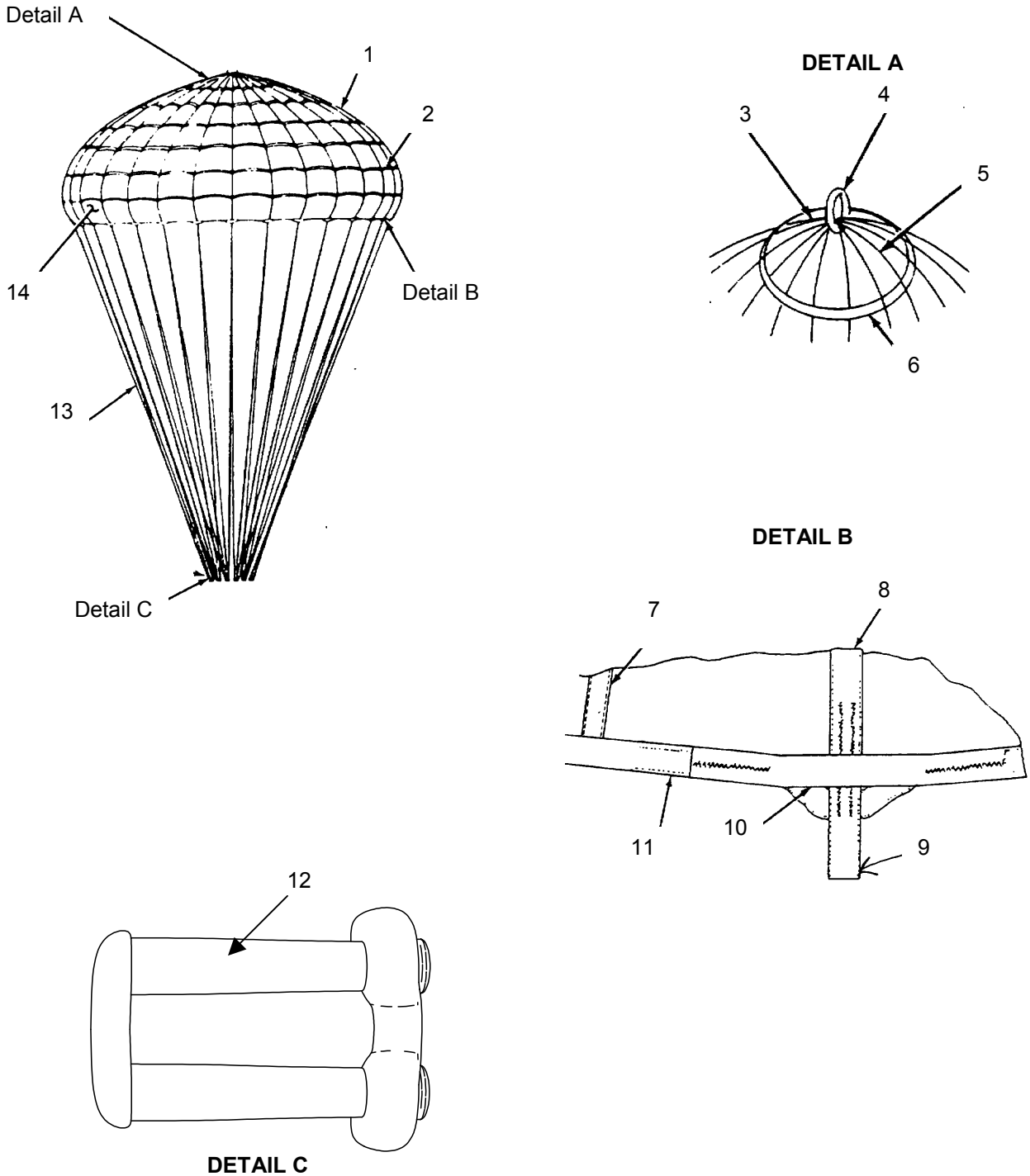

Figure 1. Canopy, 28-Foot Diameter



**GROUP 01 28-FOOT DIAMETER, CARGO EXTRACTION PARACHUTE**

(1) ITEM NO.	(2) SMR CODE	(3) NSN	(4) CAGEC	(5) PART NUMBER	(6) DESCRIPTION AND USABLE ON CODE (UOC)	(7) QTY
Group 01, Canopy, Cargo Extraction Parachute, 28-Foot Diameter Figure 1, Canopy, 28-Foot Diameter, 11-1-2146						
1	PAOOO		81337	67K1901	Canopy, Cargo, Extraction, Parachute 28-Foot, UOC: DWX	1
2	MOOOO		81337	11-1-2146-15	Reinforcement, Panel Edge, Make From Tape, Nylon, Type III, OD, ½-IN. W, PIA-T-5038 & Thread, Nylon, Size E, Type I, Class A, V-T-295, UOC: DWX	1
3	MFFFF		81337	11-1-2146-31	Line, Centering, Make From Webbing, Nylon, Size E, Type I, Class A, V-T-295, UOC: DWX	1
4	MOOOO		81337	11-1-2146-13	Loop, Attachment, Make From Webbing, Cotton, Class 3, Type X, OD 1 ¾-IN. W, MIL-W-5665 & Thread, Nylon, Size 3, Type I, Class A, V-T-295, UOC: DWX	1
5	MFFFF		81337	11-1-2146-27	Vent Line, Make From Webbing, Nylon, Tubular, ¾-IN. W, PIA-W-5625 & Thread, Nylon, Size FF, Type I, Class A, V-T-295, UOC: DWX	18
6	MOOOO		81337	11-1-2146-23	Reinforcement, Vent, Make From Webbing, Nylon, 1-IN. W, MIL-W-6525 & Thread, Nylon, Size E, Type I, Class A, V-T-295, UOC: DWX	1
7	MOOOO		81337	11-1-2146-03	Vertical Tape, Make From Tape, Nylon, Type III, ½-IN. W, OD, MIL-W-5038 & Thread, Nylon, Size E, Type I, Class A, V-T-295, UOC: DWX	36

**GROUP 01 28-FOOT DIAMETER, CARGO EXTRACTION PARACHUTE**

(1) ITEM NO.	(2) SMR CODE	(3) NSN	(4) CAGEC	(5) PART NUMBER	(6) DESCRIPTION AND USABLE ON CODE (UOC)	(7) QTY
8	MOOOO		81337	11-1-2146-17	Radial Tape, make From Tape, Nylon, Type IV, 1-IN. W, MIL-W-5038 & Thread, Nylon, Size E, Type I, Class A, V-T-295, UOC: DWX	36
9	MFFZZ		81337	11-1-2146-05	Suspension Line Attachment Loop, Make From Tape, Nylon, Type IV, 1-IN. W, OD, PIA-T-5038 & Thread, Nylon, Size 3 or FF, Type I, Class A, V-T-295, UOC: DWX	36
10	MOOOO		81337	11-1-2146-07	Pocket Band, Make From Tape, Nylon, Type IV, 1-IN. W, OD, PIA-T-5038 & Thread, Nylon, Size FF, Type I, Class A, V-T-295, UOC: DWX	36
11	MOOOO		81337	11-1-2146-21	Skirt Reinforcement, Make From Webbing, Nylon, Tubular, 1-IN. W, OD, PIA-W-5625 & Thread, Nylon, Size E, Type I, Class A, V-T-295, UOC: DWX	1
12	PAOZZ	1670-00-719-6243	96906	MS24553-1	Link, Parachute, Connector, UOC: DWX	8
13	MFFFF		81337	11-1-2146-11	Line, Suspension, Make From Webbing, Nylon, Type VI, OD, MIL-C-7515, UOC: DWX	36
14	MFFFF		81337	11-1-2146-01	Gore, Panel, Canopy, Make From Cloth, Nylon, Parachute, OD, 3.5 Oz, MIL-C-7350 & Thread, Nylon, Size E, Type I, Class A, V-T-295, UOC: DWX	36
<b>END OF FIGURE</b>						

**THIS PAGE INTENTIONALLY LEFT BLANK**

GROUP 02 ADAPTER WEB

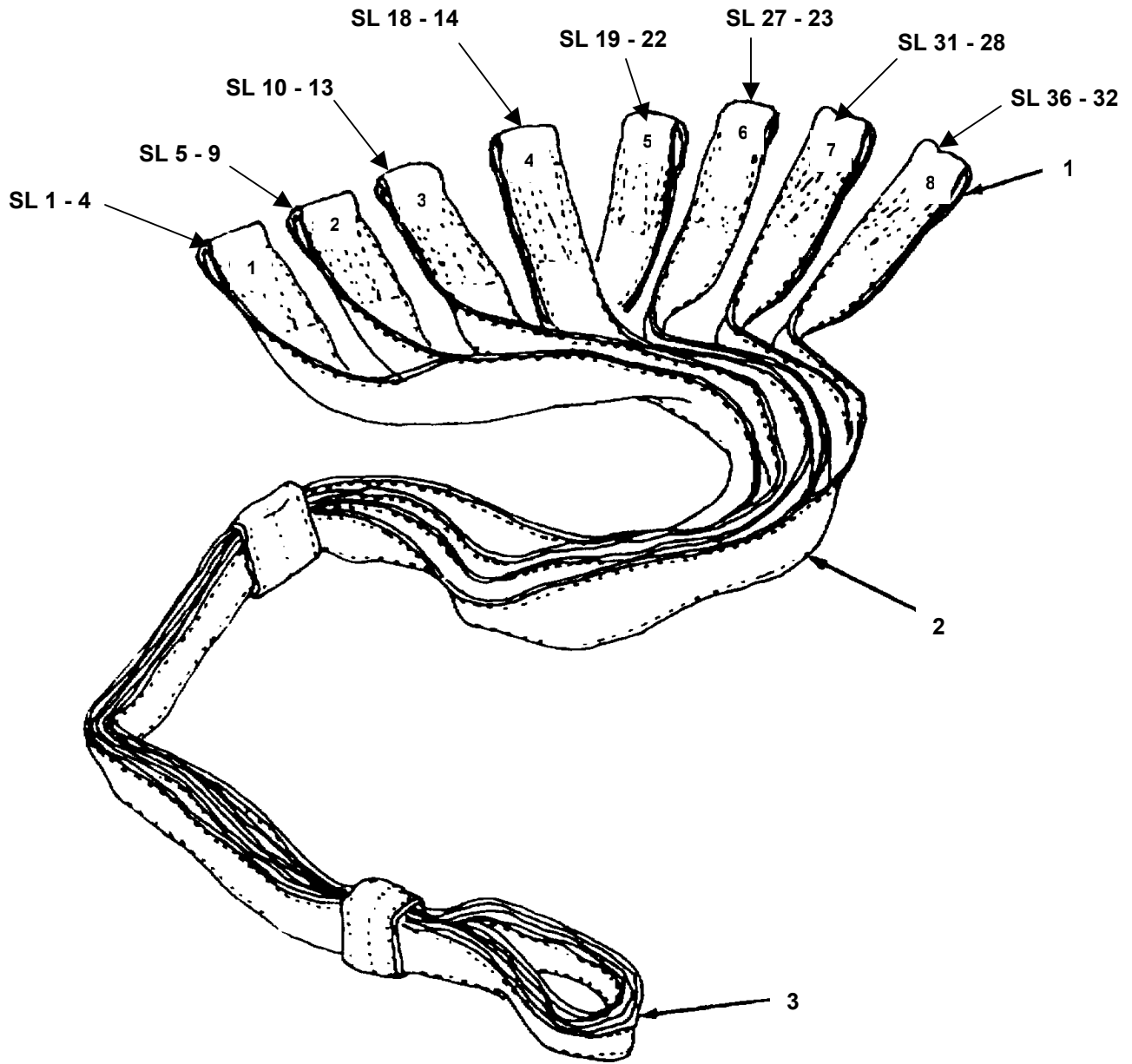

Figure 2. Adapter Web

**GROUP 02 ADAPTER WEB**

(1) ITEM NO.	(2) SMR CODE	(3) NSN	(4) CAGEC	(5) PART NUMBER	(6) DESCRIPTION AND USABLE ON CODE (UOC)	(7) QTY
Group 02, Adapter Web, Extraction Parachute Figure 2, Adapter Web, 66D1659						
1	MOOOO		81337	66D1659-7	Buffer, Heavy-Duty Short, UOC: DWX	EA
2	PAOOO	1670-00-141-3610	81377	66D1659	Adapter Web, Extraction Parachute, UOC: DWX	1
3	MOOOO		81337	66D1659-6	Buffer, Heavy-Duty Long, UOC: DWX	EA
<b>NOTE:</b> Risers 1 through 4 have the sewn portion facing up. Risers 5 through 8 have the sewn portion facing down.						
<b>END OF FIGURE</b>						

**THIS PAGE INTENTIONALLY LEFT BLANK**

**THIS PAGE INTENTIONALLY LEFT BLANK**

GROUP 03 DEPLOYMENT BAG

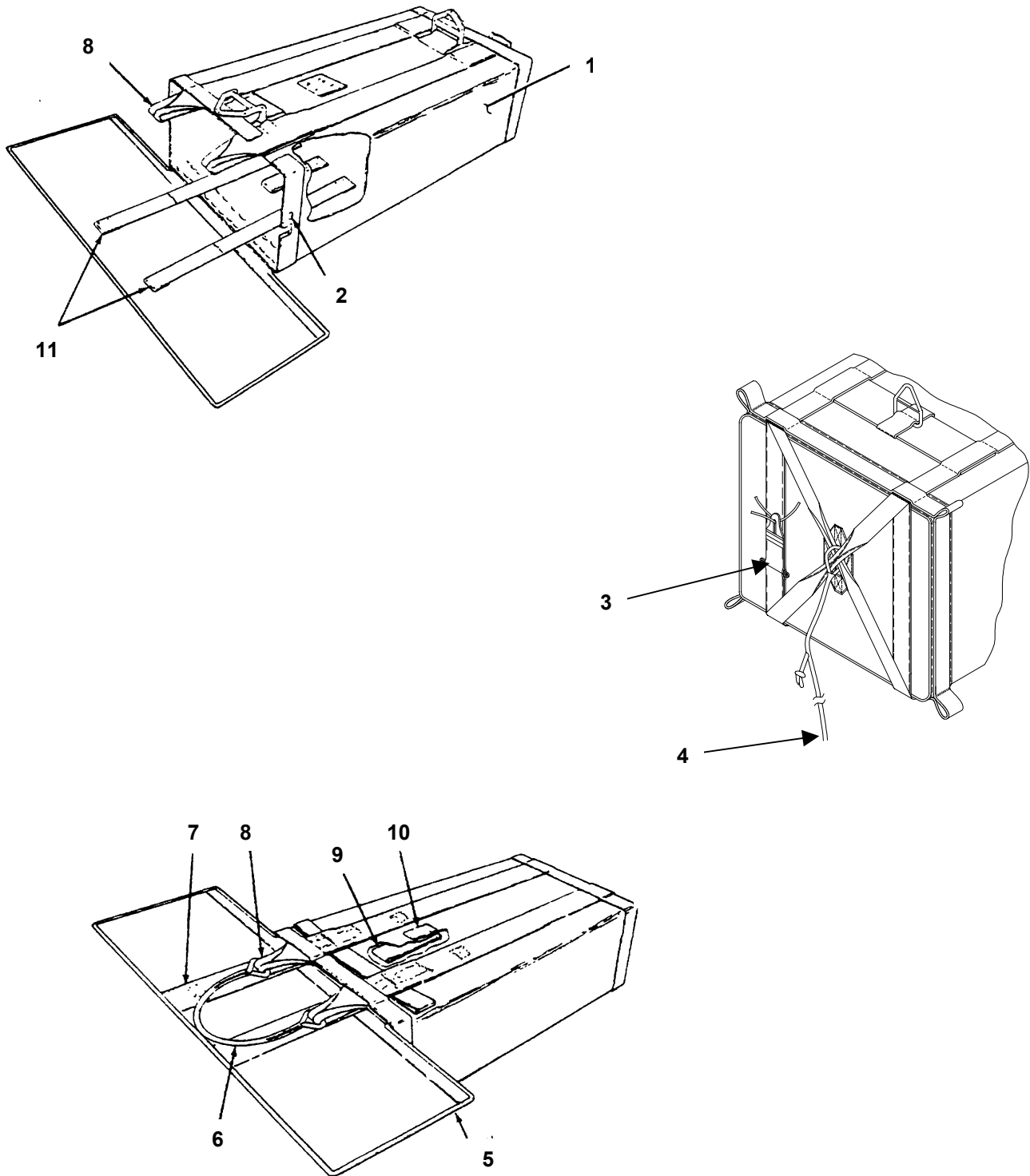

Figure 3. Deployment Bag



**GROUP 03 DEPLOYMENT BAG**

(1) ITEM NO.	(2) SMR CODE	(3) NSN	(4) CAGEC	(5) PART NUMBER	(6) DESCRIPTION AND USABLE ON CODE (UOC)	(7) QTY
Group 03, Deployment Bag, Parachute Figure 3, Deployment Bag, 66J1647						
1	PAOZZ	1670-00-127-9593	81337	66J1647	Bag, Deployment, 28-Foot Cargo Extraction Parachute. UOC: DWX	1
2	PAOZZ	5325-00-231-6589	96906	MS20230B10	Grommet, Metallic, Size 2	2
3	PAOZZ	1670-01-018-6756	81337	11-1-2587	Pocket, Log Record Book	1
4	MOOOO		81337	66J1647-19	Line, Pendulum, Make From Cord, Nylon, Type IV, OD, MIL-C-7515. UOC: DWX	1
5	MOOOO		81337	66J1647-20	Edge Binding, Make From Tape, Nylon, Type III, OD, 3/4-IN. Wide, MIL-T-5038. UOC: DWX	1
6	MOOOO		81337	66J1647-18	Safety Cord, Make From Cord, Nylon, Type IV, OD, MIL-C-7515. UOC: DWX	1
7	MOOOO		81337	66J1647-11	Reinforcement, Retainer Band Keeper, Make From Webbing, Nylon, Type VII, CL R OD, MIL-W-4088. UOC: DWX	2
8	MFFFF		81337	66J1647-EE	Bag Closing Loop, Make From Webbing, Nylon, Type VIII, OD, MIL-W-4088. UOC: DWX	4
9	MFFFF		81337	66J1647-5	Tie Loop, Make From Webbing, Nylon, Type IV, 1- IN. Wide, OD, MIL-T-5038, UOC: DWX	2
10	MOOOO		81337	66J1647-10	Reinforcement, Tie Loop, Make From Webbing, Nylon, Type IV, 1 1/2-IN. Wide, OD, MIL-T-5038. UOC: DWX	2
11	MOOOO		81337	66J1647-7	Keeper, Retainer Band, Make From Webbing, Nylon, Type IV, 1-IN. Wide, OD, MIL-T-5038. UOC: DWX	2
<b>END OF FIGURE</b>						

**THIS PAGE INTENTIONALLY LEFT BLANK**

**THIS PAGE INTENTIONALLY LEFT BLANK**

**GROUP 99 BULK MATERIALS  
REPAIR PARTS LIST**

(1) ITEM NO.	(2) SMR CODE	(3) NSN	(4) CAGEC	(5) PART NO.	(6) DESCRIPTION AND USEABLE ON CODE (UOC)	(7) QTY
<b>Group 99, Bulk Materials</b>						
1	PAOZZ	8305-00-765-2863	81349	MIL-C-4279	Cloth, Nylon, Duck, Type III, 7.25 Oz, Sage Green	YD
2	PAOZZ	8305-00-2058-1478	81349	MIL-C-7350	Cloth, Nylon, Parachute, Type II, 3.5 Oz, Natural	YD
3	PAOZZ	4020-00-965-0473	81349	MIL-C-7515	Cord, Coreless, Type V, OD	YD
4	PAOZZ	4020-00-262-2020	81349	MIL-C-7515	Cord, Nylon, Coreless, Type IV, OD	YD
5	PAOZZ	4020-00-965-0435	81349	MIL-C-7515	Cord, Nylon, Coreless, Type VI, OD	YD
6	PAOZZ	4020-00-965-0473	81349	MIL-C-7515	Cord, Nylon, Type V, OD	YD
7	PAOZZ	8315-00-253-6292	81349	MIL-T-43566	Tape, Cotton, Type I, 1½-IN., Class IV, OD,	YD
8	PAOZZ	4020-00-753-6555	81349	MIL-T-43435	Tape, Lacing and Tying	RL
9	PAOZZ	8315-00-255-7673	81349	PIA-T-5038	Tape, Nylon, Type III, ½-IN. Wide, OD	YD
10	PAOZZ	8315-00-176-8083	81349	PIA-T-5038	Tape, Nylon, Type III, ¾-IN. Wide, OD	YD
11	PAOZZ	7510-00-633-0199	81348	PPP-T-60	Tape, Pressure Sensitive, Type III, 1-IN. Wide	RL
12	PAOZZ	8315-00-253-6292	81349	MIL-T-43566	Tape, Textile, Type I, Class IV, 1½-IN. Wide, OD	YD
13	PAOZZ	8315-00-126-8083	81349	PIA-T-5038	Tape, Textile, Type III, ¾-IN. Wide	YD
14	PAOZZ	8310-00-917-3945	81348	V-T-276	Thread, Cotton, Type I, Ticket 8/7, Natural	YD
15	PAOZZ	8310-00-248-9714	81348	V-T-295	Thread, Nylon, Type I, Size 3, Class I, Natural	YD
16	PAOZZ	8310-00-267-3027	81348	V-T-295	Thread, Nylon, Type I, Size 3, Class I, OD	YD
17	PAOZZ	8310-00-248-9716	81348	V-T-295	Thread, Nylon, Type I, Size 6, Class I, Natural	YD
18	PAOZZ	8310-00-262-2780	81348	V-T-295	Thread, Nylon, Type I, Size 6, Class I, OD	YD
19	PAOZZ	8310-00-262-2770	81349	V-T-295	Thread, Nylon, Type I, Size E, Class I, Natural	YD

**GROUP 99 BULK MATERIALS  
REPAIR PARTS LIST**

(1) ITEM NO.	(2) SMR CODE	(3) NSN	(4) CAGEC	(5) PART NO.	(6) DESCRIPTION AND USEABLE ON CODE (UOC)	(7) QTY
<b>Group 99, Bulk Materials</b>						
20	PAOZZ	8310-00-262-2772	81349	V-T-295	Thread, Nylon, Type I, Size E, Class I, OD	YD
21	PAOZZ	8310-00-267-3024	81348	V-T-295	Thread, Nylon, Type I, Size FF, Class I, Natural	YD
22	PAOZZ	8310-00-227-1244	81348	V-T-295	Thread, Nylon, Type I, Size FF, Class I, OD	YD
23	PAOZZ	8305-00-268-2411	81349	MIL-T-5661	Webbing, Cotton, Type I, ¼-IN. Wide, Natural	YD
24	PAOZZ	8305-00-753-6086	81349	MIL-W-5665	Webbing, Cotton, Type X, 1¼-IN. Wide, OD	YD
25	PAOZZ	8305-00-082-5751	81349	PIA-W-5625	Webbing, Nylon, Tubular, ¾-IN. Wide, Natural	YD
26	PAOZZ	8305-00-268-2455	81349	PIA-W-5625	Webbing, Nylon, Tubular, 1-IN. Wide, OD	YD
27	PAOZZ	8305-00-268-2453	81349	PIA-W-5625	Webbing, Nylon, Tubular, Textile, ½-IN. Wide	YD
28	PAOZZ	8305-00-263-2472	81349	MIL-W-5038	Webbing, Nylon, Type IV, 1½ -IN. Wide, OD	YD
29	PAOZZ	8305-00-261-8579	81349	PIA-T-5038	Webbing, Nylon, Type IV, 1-IN. Wide, OD	YD
30	PAOZZ	8305-00-263-3598	81349	PIA-W-4088	Webbing, Nylon, Type VIII, 1 <sup>23</sup> / <sub>32</sub> .IN. Wide, OD	YD
31	PAOZZ		81349	MIL-W-42765	Webbing, Textile, Cotton, Type VIII, Class R, OD	YD
32	PAOZZ	8305-00-261-8579	81349	MIL-T-5038	Webbing, Textile, Nylon, Type IV, 1-IN. Wide, OD	YD
33	PAOZZ	8305-00-260-2564	81349	MIL-W-5665	Webbing, Textile, Type VIII, Class 2B, OD	YD
<b>END OF FIGURE</b>						

**THIS PAGE INTENTIONALLY LEFT BLANK**

---

**28-FOOT DIAMETER, CARGO EXTRACTION PARACHUTE  
SPECIAL TOOLS LIST**

---

*Not Applicable*

**END OF WORK PACKAGE**

**THIS PAGE INTENTIONALLY LEFT BLANK**



---

**28-FOOT DIAMETER, CARGO EXTRACTION PARACHUTE  
NATIONAL STOCK NUMBER INDEX**

---

<b>NATIONAL STOCK NUMBER INDEX</b>		
<b>STOCK NUMBER</b>	<b>FIGURE</b>	<b>ITEM</b>
1670-01-018-6756	3	3
8305-00-082-5751	BULK	25
8315-00-126-8083	BULK	13
1670-00-127-9593	3	1
1670-00-141-3610	2	2
8315-00-176-8083	BULK	10
8305-00-2058-1478	BULK	2
8310-00-227-1244	BULK	22
5325-00-231-6589	3	2
8310-00-248-9714	BULK	15
8310-00-248-9716	BULK	17
8315-00-253-6292	BULK	7
8315-00-253-6292	BULK	12
8315-00-255-7673	BULK	9
8305-00-260-2564	BULK	33
8305-00-261-8579	BULK	29
8305-00-261-8579	BULK	32
4020-00-262-2020	BULK	4
8310-00-262-2770	BULK	19
8310-00-262-2772	BULK	20
8310-00-262-2780	BULK	18
8305-00-263-2472	BULK	28
8305-00-263-3598	BULK	30
8310-00-267-3024	BULK	21
8310-00-267-3027	BULK	16
8305-00-268-2411	BULK	23
8305-00-268-2453	BULK	27
8305-00-268-2455	BULK	26
7510-00-633-0199	BULK	11
1670-00-719-6243	1	12
8305-00-753-6086	BULK	24
4020-00-753-6555	BULK	8
8305-00-765-2863	BULK	1
8310-00-917-3945	BULK	14
4020-00-965-0435	BULK	5
4020-00-965-0473	BULK	3
4020-00-965-0473	BULK	6
<b>END OF FIGURE</b>		

**THIS PAGE INTENTIONALLY LEFT BLANK**

**28-FOOT DIAMETER, CARGO EXTRACTION PARACHUTE  
PART NUMBER INDEX**

PART NUMBER INDEX		
PART NUMBER	FIGURE	ITEM
11-1-2146	1	1
11-1-2146-01	1	14
11-1-2146-03	1	7
11-1-2146-05	1	9
11-1-2146-07	1	10
11-1-2146-11	1	13
11-1-2146-13	1	4
11-1-2146-15	1	2
11-1-2146-17	1	8
11-1-2146-21	1	11
11-1-2146-23	1	6
11-1-2146-27	1	5
11-1-2146-31	1	3
11-1-2587	3	3
66D1659	2	2
66D1659-6	2	3
66D1659-7	2	1
66J1647	3	1
66J1647-10	3	10
66J1647-11	3	7
66J1647-18	3	6
66J1647-19	3	4
66J1647-20	3	5
66J1647-5	3	9
66J1647-7	3	11
66J1647-EE	3	8
MIL-C-4279	BULK	1
MIL-C-7350	BULK	2
MIL-C-7515	BULK	3
MIL-C-7515	BULK	4
MIL-C-7515	BULK	5
MIL-C-7515	BULK	6
MIL-T43435	BULK	8
MIL-T-43566	BULK	7
MIL-T-43566	BULK	12
MIL-T-5038	BULK	32
MIL-T-5661	BULK	23
MIL-W-42765	BULK	31
MIL-W-5038	BULK	28
MIL-W-5665	BULK	24
MIL-W-5665	BULK	33
MS20230B10	3	2
MS24553-1	1	12

PART NUMBER INDEX - continued		
PART NUMBER	FIGURE	ITEM
PIA-T-5038	BULK	29
PIA-T-5038	BULK	9
PIA-T-5038	BULK	10
PIA-T-5038	BULK	13
PIA-W-4088	BULK	30
PIA-W-5625	BULK	25
PIA-W-5625	BULK	26
PIA-W-5625	BULK	27
PPP-T-60	BULK	11
V-T-276	BULK	14
V-T-295	BULK	20
V-T-295	BULK	21
V-T-295	BULK	22
V-T-295	BULK	15
V-T-295	BULK	16
V-T-295	BULK	17
V-T-295	BULK	18
V-T-295	BULK	19
<b>END OF FIGURE</b>		

**THIS PAGE INTENTIONALLY LEFT BLANK**

---

**28-FOOT DIAMETER, CARGO EXTRACTION PARACHUTE  
EXPENDABLE/DURABLE SUPPLIES AND MATERIALS LIST**

---

**SCOPE**

This work package lists expendable and durable items that you will need to operate and maintain the 28-Foot Diameter, Cargo Extraction Parachute. These items are authorized to you by CTA 50-970, Expendable/Durable Items (Except Medical, Class V, Repair Parts, and Heraldic Items) or CTA 8-100, Army Medical Department Expendable/Durable Items.

**EXPLANATION OF COLUMNS**

**Column 1, Item Number.** This number is assigned to the entry in the list and is referenced in the narrative instructions to identify the item (e.g., Use Cloth, Abrasive (Item 3,WP 0065 00).

**Column 2, Level.** This column identifies the lowest level of maintenance that requires the listed item. (O = Unit Maintenance).

**Column 3, National Stock Number.** This is the NSN assigned to the item; use it to request or requisition the item.

**Column 4, Item Name, Description, Commercial and Government Entity Code (CAGEC), and Part Number (P/N).** This column provides the other information you need to identify the item.

**Column 5, Unit of Measure (U/M).** This code shows the physical measurement or count of an item, such as gallon, dozen, gross, etc.

**Table 1. Expendable/Durable Supplies and Materials List**

(1) ITEM NUMBER	(2) LEVEL	(3) NATIONAL STOCK NUMBER	(4) ITEM NAME, DESCRIPTION, CAGE, PART NUMBER	(5) UNIT OF MEASURE
1	O	1670-00-568-0323	Band, Retainer, Rubber (81349) MIL-B-1832	BX
2	O	9160-00-253-1171	Beeswax, Technical, 1-Lb (81348) C-B-191	LB
3	O	5350-00-221-0872	Cloth, Abrasive, Ferric Oxide and Quartz (81348) P-C-458	EA
4	O	8305-00-765-2863	Cloth, Nylon, Duck, Type III, 7.25 Oz, Sage Green (81349) MIL-C-4279	YD
5	O	8305-00-205-1478	Cloth, Nylon, Parachute, Type II, 3.5 Oz, OG (81349) MIL-C-7350	YD
6	O	4020-00-262-2020	Cord, Nylon, Coreless, Type IV, OD (81349) MIL-C-7515	YD

**28-FOOT DIAMETER, CARGO EXTRACTION PARACHUTE  
EXPENDABLE/DURABLE SUPPLIES AND MATERIALS LIST**
**Table 1. Expendable/Durable Supplies and Materials List - Continued**

(1) ITEM NUMBER	(2) LEVEL	(3) NATIONAL STOCK NUMBER	(4) ITEM NAME, DESCRIPTION, CAGE, PART NUMBER	(5) UNIT OF MEASURE
7	O	4020-00-965-0435	Cord, Nylon, Coreless, Type VI, OD (81349) MIL-C-7515	YD
8	O	4020-00-965-0473	Cord, Nylon, Type V, OD (81349) MIL-C-7515	YD
9	O	7930-00-281-4730	Dishwashing Compound, Hand, Flake (81348) P-D-410	LB
10	O	7510-00-286-5362	Ink, Marking, Parachute, Strata-Blue (81349) MIL-I-6903	PT
11	O	9150-00-168-2000	Lubricant, Solid Film	CN
12	O	7510-00-240-1525	Marker, China, White	
13	O	7520-00-230-2734	Marker, Felt Tip, Black (81348) GG-M-0014	EA
14	O	7520-00-491-2917	Pen, Ballpoint (81348) GG-B-0060	EA
15	O	7920-00-205-3570	Rag, Wiping (81348) DDD-R-30	BE
16	O	9310-00-160-7858	Stencilboard, Oiled (81348) UU-S-625 Type II	SH
17	O	8315-00-253-6292	Tape, Cotton, Type I, 1½-IN., OD (81349) MIL-T-43566, CL4	YD
18	O	4020-00-753-6555	Tape, Lacing and Tying	RO
19	O	8315-00-255-7673	Tape, Nylon, Type III, ½-IN., OD (81349) MIL-T-5038	YD
20	O	8315-00-176-8083	Tape, Nylon, Type III, ¾-IN, OD (81349) MIL-T-5038	YD
21	O	7510-00-633-0199	Tape, Pressure Sensitive, Type III, 1-IN. (81348) PPP-T-60	RL
22	O	8310-00-917-3944	Thread, Cotton, Ticket No. 8/4, Natural (81348) V-T-276	YD

**28-FOOT DIAMETER, CARGO EXTRACTION PARACHUTE  
EXPENDABLE/DURABLE SUPPLIES AND MATERIALS LIST**
**Table 1. Expendable/Durable Supplies and Materials List - Continued**

(1) ITEM NUMBER	(2) LEVEL	(3) NATIONAL STOCK NUMBER	(4) ITEM NAME, DESCRIPTION, CAGE, PART NUMBER	(5) UNIT OF MEASURE
23	O	8310-00-917-3945	Thread, Cotton, Ticket No. 8/7, Natural (81348) V-T-276	YD
24	O	8310-00-248-9714	Thread, Nylon, Size 3, Natural White (81348) V-T-295	YD
25	O	8310-00-267-3027	Thread, Nylon, Size 3, OD (81348) V-T-295	YD
26	O	8310-00-248-9715	Thread, Nylon, Size 5, Natural White (81348) V-T-295	YD
27	O	8310-00-262-2777	Thread, Nylon, Size 5, OD (81348) V-T-295	YD
28	O	8310-00-248-9716	Thread, Nylon, Size 6, Natural White (81348) V-T-295	YD
29	O	8310-00-262-2780	Thread, Nylon, Size 6, OD (81348) V-T-295	YD
30	O	8310-00-262-2770	Thread, Nylon, Size E, Natural White (81348) V-T-295	YD
31	O	8310-00-262-2772	Thread, Nylon, Size E, OD (81348) V-T-295	YD
32	O	8310-00-267-3024	Thread, Nylon, Size FF, Natural White (81348) V-T-295	YD
33	O	8310-00-227-1244	Thread, Nylon, Size FF, OD (81348) V-T-295	YD
34	O	9160-00-285-2044	Wax, Paraffin, Technical, Type I, Grade A, 1 Lb (81348) VV-W-95	LB
35	O	8305-00-268-2411	Webbing, Cotton, Type I, ¼-IN., Natural (81349) MIL-T-5661	YD
36	O	8305-00-260-2564	Webbing, Cotton, Type VIII, 1¾-IN.	FT
37	O	8305-00-753-6086	Webbing, Cotton, Type X, OD (81349) MIL-W-5665	YD

**28-FOOT DIAMETER, CARGO EXTRACTION PARACHUTE  
EXPENDABLE/DURABLE SUPPLIES AND MATERIALS LIST**

**Table 1. Expendable/Durable Supplies and Materials List - Continued**

(1) ITEM NUMBER	(2) LEVEL	(3) NATIONAL STOCK NUMBER	(4) ITEM NAME, DESCRIPTION, CAGE, PART NUMBER	(5) UNIT OF MEASURE
38	O	8305-00-082-5751	Webbing, Nylon, Tubular, ¾-IN., Natural (81349) MIL-W-5625	YD
39	O	8305-00-268-2455	Webbing, Nylon, Tubular, 1-IN., OD (81349) MIL-W-5625	YD
40	O	8305-00-263-2472	Webbing, Nylon, Type IV, 1½-IN., OD (81349) MIL-T-5038	YD
41	O	8305-00-261-8579	Webbing, Nylon, Type IV, 1-IN., OD (81349) MIL-T-5038	YD
42	O	8305-261-8585	Webbing, Nylon, Type VIII, OD (81349) MIL-W-4088	YD
43	O	8305-00-268-2453	Webbing, Textile, Nylon, Tubular, ½-IN. Wide	YD
44	O	9505-00-892-4616	Wire, Steel, 0.080 Diameter (81348) QQ-W-423	CL

**END OF WORK PACKAGE**



**28-FOOT DIAMETER, CARGO EXTRACTION PARACHUTE  
ILLUSTRATED LIST OF MANUFACTURED ITEMS**

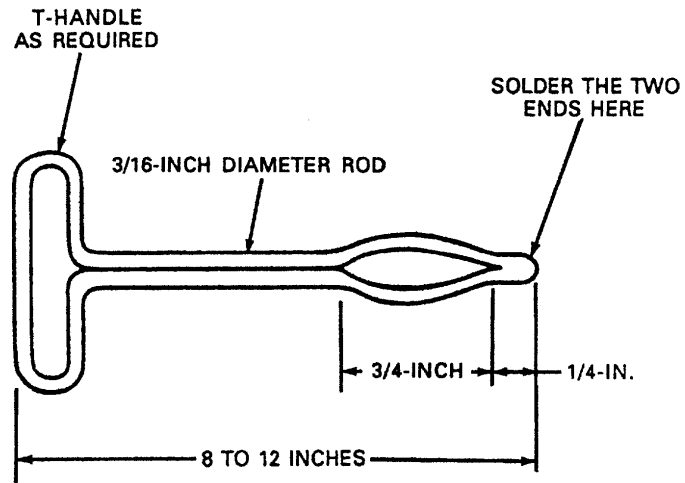

**Splicing Aid Fabrication**

**END OF WORK PACKAGE**

**THIS PAGE INTENTIONALLY LEFT BLANK**

## ALPHABETICAL INDEX

Subject	WP Sequence No. – Page No.
<b>A</b>	
Accomplishing a Log Record .....	0003 00-4
Accordion Folding/Rigger Rolling .....	0054 00-2
Acronyms and Abbreviations .....	0001 00-3
Adapter Web Body .....	0030 00-1
Adapter Web Fixed Keeper .....	0033 00-1
Adapter Web Long Buffer .....	0031 00-1
Adapter Web Short Buffer .....	0032 00-1
Adapter Web .....	0029 00-1
After-Use Receipt .....	0003 00-9
Air Force Technical Order Forms .....	0055 00-2
Air Force Technical Orders .....	0055 00-2
Airing (and Shakeout) (Unit) .....	0007 00-1
Army Regulations .....	0055 00-2
Assembling the 28-Foot Cargo Extraction Parachute .....	0004 00-1
Assembly Specifics .....	0002 00-3
Attaching Universal Static Line .....	0011 00-55
Attachment Loop (Bridle Loop) .....	0016 00-1
<b>B</b>	
(Bridle Loop), Attachment Loop (Unit) .....	0016 00-1
Basting (DS) .....	0046 00-1
Basting (Unit) .....	0012 00-1
Bridle Centering Line (DS) .....	0050 00-1
Bridle Centering Line (Unit) .....	0018 00-1
Bulk Materials List .....	0051 00-2
<b>C</b>	
Checking Unpacked Equipment After Shipment .....	0003 00-9
Cleaning and Drying (Unit) .....	0008 00-1
Cleaning Fabric Items With Hand Dishwashing Compound .....	0008 00-1
Cleaning Metal Items .....	0008 00-2
Common Name .....	0001 00-3
Common Tools and Equipment .....	0001 00-5
Configuration/Condition .....	0003 00-2
Connector Link .....	0028 00-1
Contingency Parachute Stock .....	0053 00-1
Contingency Parachute Stock (Non-Depot) .....	0053 00-1
Corrosion Prevention And Control (CPC) .....	0001 00-2

**Subject**

**WP Sequence No. – Page No.**

**D**

Darning (Unit).....	0012 00-4
Deployment Bag Closing Loop .....	0042 00-1
Deployment Bag Panels and Flaps.....	0044 00-1
Deployment Bag Pendulum Line .....	0039 00-1
Deployment Bag Retainer Band Keeper Reinforcement .....	0037 00-1
Deployment Bag Retainer Band Keeper.....	0036 00-1
Deployment Bag Retainer Band Keeper.....	0036 00-1
Deployment Bag Safety Cord.....	0041 00-1
Deployment Bag Stowage Flap Edge Binding.....	0043 00-1
Deployment Bag Stowage Flap Edge Reinforcement .....	0045 00-1
Deployment Bag Tie Loop Reinforcement.....	0038 00-1
Deployment Bag.....	0034 00-1
Description Of Major Components.....	0002 00-1
Destruction Of Army Materiel To Prevent Enemy Use .....	0001 00-2
Drop Testing Criteria .....	0005 00-1
Drying Fabric Items.....	0008 00-2

**E**

Equipment Characteristics, Capabilities And Features.....	0002 00-1
Equipment Data .....	0002 00-3
Equipment Description and Data .....	0002 00-1
Equipment Disposition .....	0009 00-3
Equipment Improvements and Recommendations, Reporting (EIR).....	0001 00-1
Equipment Name .....	0001 00-1
Expendable/Durable Supplies and Materials List .....	0065 00-1
Explanation of Columns in Remarks, Table 3.....	0056 00-3
Explanation of Columns in the Tools and Test Equipment Requirements, Table 2 .....	0056 00-3

**F**

Field Manuals.....	0055 00-21
Forms .....	0055 00-2
Fresh-Water Contamination Test.....	0010 00-1

**G**

General Information .....	0001 00-1
General Procedures for Air Delivery Equipment.....	0003 00-1
General Storage Requirements .....	0053 00-1
Gore Sections, Repair (Unit).....	0020 00-1
Gore Sections, Replace (DS).....	0051 00-1
Grommet .....	0035 00-1

**Subject** **WP Sequence No. – Page No.**

**H**

How to Locate Repair Parts ..... 0057 00-7  
 How to Use this Manual ..... v

**I**

Illustrated List of Manufactured Items ..... 0066 00-1  
 Initial Receipt..... 0003 00-1  
 Inspection Personnel ..... 0003 00-1  
 Inspection ..... 0009 00-1  
 Installing Attaching Tie ..... 0003 00-2  
 In-Storage Inspection ..... 0009 00-2

**J**

Jump, Inspection, and Repack Data Page ..... 0003 00-7

**L**

(Lower Lateral Band) Skirt Reinforcement..... 00024 00-1  
 List of Acronyms and Abbreviations..... 0001 00-3  
 List of Effective Pages ..... A  
 Locating Suspension Lines ..... 0011 00-5  
 Location And Description of Major Components..... 0002 00-1  
 Log Record Book Pocket ..... 0040 00-1

**M**

Maintenance Allocation Chart (MAC), Introduction..... 0056 00-1  
 Maintenance Allocation Chart (MAC), Table 1..... 0056 00-4  
 Maintenance Forms, Records and Reports ..... 0001 00-1  
 Maintenance Functions ..... 0056 00-1  
 Maintenance Functions/Procedures ..... 0005 00-1  
 Marine Corps Forms ..... 0055 00-3  
 Marking and Restencilling (DS) ..... 0048 00-1  
 Marking and Restencilling (Unit) ..... 0014 00-1  
 Modification Work Order Compliance Record Page ..... 0003 00-5

**N**

National Stock Number Index ..... 0063 00-1  
 Nomenclature Cross-Reference List..... 0001 00-3  
 Note Page ..... 0003 00-7

**Subject**

**WP Sequence No. – Page No.**

**O**

Official Name .....	0001 00-3
Orientation .....	0011 00-2

**P**

Packing 28-Foot Cargo Extraction Parachute .....	0011 00-8
Packing 28-Foot Cargo Extraction Parachute For Dual Row Airdrop .....	0011 00-18
Packing Procedures .....	0011 00-1
Pack-In-Process Inspection .....	0009 00-1
Pamphlets .....	0055 00-1
Panel Edge Reinforcement .....	0023 00-1
Parachute Log Record .....	0003 00-2/0053 00-3
Parachute Repack Interval .....	0005 00-1
Part Number Index .....	0064 00-1
Pocket Band .....	00215 00-1
Preparation for Shipment .....	0001 00-3
Preparation for Storage .....	0001 00-3/0053 00-1
Preparing Parachute for Proper Layout .....	0011 00-3
Preparing the 28-Foot Deployment Parachute With Release Away Static Line .....	0011 00
Preventive Maintenance Checks And Services (PMCS) .....	0006 00-1
Preventive Maintenance Checks And Services (PMCS), Introduction .....	0005 00-1
Publication Indexes .....	0055 00-1
Purpose of Equipment.....	0001 00-1

**R**

Radial Tape, Repair (Unit) .....	0021 00-1
Receipt of Used Parachute .....	0003 00-9
References .....	0055 00-1
References, Air Force Technical Order Forms .....	0055 00-2
References, Air Force Technical Orders.....	0055 00-2
References, Army Regulations .....	0055 00-2
References, DA PAM .....	0055 00-1
References, Field Manuals .....	0055 00-1
References, Forms.....	0055 00-2
References, Marine Corps Forms.....	0055 00-3
References, Publication Indexes .....	0055 00-1
References, Technical Manuals.....	0055 00-1
Remarking and Restencilling (DS).....	0048 00-2
Remarking and Restencilling (Unit) .....	0014 00-2
Removing Inversion .....	0011 00-3
Repair Parts and Special Tools List (RPSTL).....	0057 00 to 0061 00
Repair Parts and Special Tools List (RPSTL), Introduction.....	0057 00-1
Replacing a Filled Out or Unserviceable Log Record.....	0003 00-8

**Subject**

**WP Sequence No. – Page No.**

**R - Continued**

Replacing a Lost Log Record.....	0003 00-8
Reporting Equipment Improvement Recommendations (EIRs).....	0001 00-1
Reporting Errors and Recommending Improvements .....	i
Restenciling (DS).....	0048 00-1
Restenciling (Unit).....	0014 00-1
Restitching (DS).....	0046 00-2
Restitching (Unit).....	0012 00-2
Rigger Rolling.....	0054 00-4
Rigger's Orientation .....	0011 00-6
Rinsing Equipment Immersed in Fresh-Water.....	0008 00-4/0010 00-2
Rinsing Equipment Immersed in Salt-Water.....	0008 00-3/0010 00-1
Routine Inspection .....	0009 00-1

**S**

Safety, Care and Handling.....	0001 00-4
Salt-Water Contamination Test.....	0010 00-1
Searing and Waxing (DS).....	0047 00-1
Searing and Waxing (Unit).....	0013 00-1
Service Upon Receipt .....	0003 00-1
Sewing Machine Code Symbols, Table 1 (DS).....	0046 00-2
Sewing Machine Code Symbols, Table 1 (Unit).....	0012 00-2
Sewing Procedures (DS).....	0046 00-1
Sewing Procedures (Unit).....	0012 00-1
Shakeout and Airing (Unit).....	0007 00-1
Shipment.....	0054 00-1
Skirt Reinforcement (Lower Lateral Band).....	0024 00-1
Special Tools List.....	0052 00-1
Special Tools, TMDE and Support Equipment .....	0001 00-5
Stitching (DS).....	0046 00-2
Stitching (Unit).....	0012 00-2
Stitching and Restitching Specifications, Table 2 (DS).....	0046 00-2
Stitching and Restitching Specifications, Table 2 (Unit).....	0012 00-3
Storage Specifics for Parachutes.....	0053 00-1
Suspension Line (DS).....	0052 00-1
Suspension Line (Unit).....	0027 00-1
Suspension Line Attachment Loop .....	0026 00-1

**T**

Table of Contents.....	ii
Technical Bulletins .....	0041 00-2
Technical Manuals .....	0055 00-1
Technical/Rigger-Type Inspection .....	0009 00-2
Temporary Tacking (DS).....	0046 00-1
Temporary Tacking (Unit).....	0012 00-1
Tools and Test Equipment Requirements, Table 2 .....	0056 00-5

**Subject**

**WP Sequence No. – Page No.**

**U**

Unit and Direct Support Repair and Inspection Data.....0003 00-6  
Usable On Code .....0057 00-7

**V**

Vent Lines, Repair (Unit).....0017 00-1  
Vent Lines, Replace (DS).....0049 00-1  
Vent Reinforcement Band (Upper Lateral Band) .....0019 00-11  
Vertical Tape .....0022 00-1

**W**

Warning Summary ..... a  
Warranty Information.....0001 00-3  
Waxing (DS).....0047 00-1  
Waxing (Unit) .....0013 00-1



By Order of the Secretaries of the Army, Air Force, and Navy (Including the Marine Corps):

Official:



JOEL B. HUDSON  
*Administrative Assistant to the  
Secretary of the Army*  
0209504

ERIC K. SHINSEKI  
*General, United States Army  
Chief of Staff*

**MICHAEL E. RYAN**  
*GENERAL, USAF  
Chief of Staff*

Official:

**GEORGE T. BABBETT**  
*General, USAF  
Commander, Air Force Materiel Command*

**D.G. MORRAL**  
*Rear Admiral, USN  
Program Executive Officer  
For Expeditionary Warfare  
Naval Sea Systems Command*

**R.P. SHOCKEY**  
*Director, Program Support  
Marine Corps Systems Command*

DISTRIBUTION:

To be distributed in accordance with Initial Distribution Number (IDN 252691), requirements for TM 10-1670-277-23&P.

THIS PAGE INTENTIONALLY LEFT BLANK

## ***These are the instructions for sending an electronic 2028***

The following format must be used if submitting an electronic 2028. The subject line must be exactly the same and all fields must be included; however only the following fields are mandatory: 1, 3, 4, 5, 6, 7, 8, 9, 10, 13, 15, 16, 17, and 27.

From: "Whomever" <whomever@avma27.army.mil>

To: amssb-rim-e@natick.army.mil

Subject: DA Form 2028

1. **From:** Joe Smith
2. **Unit:** home
3. **Address:** 4300 Park
4. **City:** Hometown
5. **St:** MO
6. **Zip:** 77777
7. **Date Sent:** 19-OCT-93
8. **Pub no:** 55-2840-229-23
9. **Pub Title:** TM
10. **Publication Date:** 04-JUL-85
11. **Change Number:** 7
12. **Submitter Rank:** MSG
13. **Submitter FName:** Joe
14. **Submitter MName:** T
15. **Submitter LName:** Smith
16. **Submitter Phone:** 123-123-1234
17. **Problem:** 1
18. **Page:** 2
19. **Paragraph:** 3
20. **Line:** 4
21. **NSN:** 5
22. **Reference:** 6
23. **Figure:** 7
24. **Table:** 8
25. **Item:** 9
26. **Total:** 123
27. **Text:**

This is the text for the problem below line 27.

**THIS PAGE INTENTIONALLY LEFT BLANK**

RECOMMENDED CHANGES TO EQUIPMENT TECHNICAL PUBLICATIONS



THEN ...JOT DOWN THE DOPE ABOUT IT ON THIS FORM, CAREFULLY TEAR IT OUT, FOLD IT AND DROP IT IN THE MAIL!

**SOMETHING WRONG WITH THIS PUBLICATION?**

FROM: (PRINT YOUR UNIT'S COMPLETE ADDRESS)  
 PFC John DOE  
 Co A 3rd Engineer Bn  
 Ft. Leonardwood, MO 63108

DATE SENT  
 22 August 1992

PUBLICATION NUMBER TM 1-1520-250-10	PUBLICATION DATE 15 June 1992	PUBLICATION TITLE Operator's manual MH60K Helicopter
----------------------------------------	----------------------------------	---------------------------------------------------------

BE EXACT PIN-POINT WHERE IT IS				IN THIS SPACE, TELL WHAT IS WRONG AND WHAT SHOULD BE DONE ABOUT IT:
PAGE NO	PARA-GRAPH	FIGURE NO	TABLE NO	
6	2-1 a			In line 6 of paragraph 2-1a the manual states the engine has 6 cylinders. The engine on my set only has 4 cylinders. Change the manual to show 4 cylinders.
B1		4-3		Callout 16 in figure 4-3 is pointed out bolt. In key to figure 4-3, item 16 is called a shim. Please correct one or the other

PRINTED NAME, GRADE OR TITLE, AND TELEPHONE NUMBER JOHN DOE, PFC (268) 317-7111	SIGN HERE JOHN DOE <i>John Doe</i>
------------------------------------------------------------------------------------	---------------------------------------

DA FORM 2028-2  
1 JUL 79

PREVIOUS EDITIONS ARE OBSOLETE.  
DRSTS-M verprint2, 1 Nov 80

P.S. - IF YOUR OUTFIT WANTS TO KNOW ABOUT YOUR RECOMMENDATION, MAKE A CARBON COPY OF THIS AND GIVE TO YOUR HEADQUARTERS.

FILL IN YOUR  
UNITS ADDRESS



FOLD BACK

DEPARTMENT OF THE ARMY

---

---

OFFICIAL BUSINESS

COMMANDER  
U.S. ARMY SOLDIER AND BIOLOGICAL CHEMICAL COMMAND  
ATTN: AMSSB-RIM-E  
KANSAS STREET  
NATICK, MA 01760-5052

TEAR ALONG PERFORATED LINE

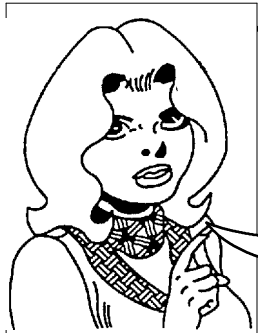

THEN . . . JOT DOWN THE DOPE ABOUT IT ON THIS FORM, CAREFULLY TEAR IT OUT, FOLD IT AND DROP IT IN THE MAIL!

# SOMETHING WRONG WITH THIS PUBLICATION?

FROM: (PRINT YOUR UNIT'S COMPLETE ADDRESS)

DATE SENT

PUBLICATION NUMBER  
TM 10-1670-277-23&P

PUBLICATION DATE  
30 March 2002

PUBLICATION TITLE  
28-Foot Diameter Cargo Extraction Parachute

BE EXACT PIN-POINT WHERE IT IS IN THIS SPACE, TELL WHAT IS WRONG AND WHAT SHOULD BE DONE ABOUT IT:

PAGE NO	PARA-GRAPH	FIGURE NO	TABLE NO

PRINTED NAME, GRADE OR TITLE, AND TELEPHONE NUMBER

SIGN HERE

FILL IN YOUR  
UNITS ADDRESS



FOLD BACK

DEPARTMENT OF THE ARMY

\_\_\_\_\_

\_\_\_\_\_

OFFICIAL BUSINESS

COMMANDER  
U.S. ARMY SOLDIER AND BIOLOGICAL CHEMICAL COMMAND  
ATTN: AMSSB-RIM-E  
KANSAS STREET  
NATICK, MA 01760-5052

TEAR ALONG PERFORATED LINE





THEN . . . JOT DOWN THE DOPE ABOUT IT ON THIS FORM, CAREFULLY TEAR IT OUT, FOLD IT AND DROP IT IN THE MAIL!

# SOMETHING WRONG WITH THIS PUBLICATION?

FROM: (PRINT YOUR UNIT'S COMPLETE ADDRESS)

DATE SENT

PUBLICATION NUMBER

TM 10-1670-277-23&P

PUBLICATION DATE

30 March 2002

PUBLICATION TITLE

28-Foot Diameter Cargo Extraction Parachute

BE EXACT PIN-POINT WHERE IT IS IN THIS SPACE, TELL WHAT IS WRONG AND WHAT SHOULD BE DONE ABOUT IT:

PAGE NO	PARA- GRAPH	FIGURE NO	TABLE NO

PRINTED NAME, GRADE OR TITLE, AND TELEPHONE NUMBER

SIGN HERE

FILL IN YOUR  
UNITS ADDRESS



FOLD BACK

DEPARTMENT OF THE ARMY

\_\_\_\_\_

\_\_\_\_\_

OFFICIAL BUSINESS

COMMANDER  
U.S. ARMY SOLDIER AND BIOLOGICAL CHEMICAL COMMAND  
ATTN: AMSSB-RIM-E  
KANSAS STREET  
NATICK, MA 01760-5052

TEAR ALONG PERFORATED LINE

## The Metric System and Equivalents

### *Linear Measure*

1 centimeter = 10 millimeters = .39 inch  
 1 decimeter = 10 centimeters = 3.94 inches  
 1 meter = 10 decimeters = 39.37 inches  
 1 dekameter = 10 meters = 32.8 feet  
 1 hectometer = 10 dekameters = 328.08 feet  
 1 kilometer = 10 hectometers = 3,280.8 feet

### *Weights*

1 centigram = 10 milligrams = .15 grain  
 1 decigram = 10 centigrams = 1.54 grains  
 1 gram = 10 decigrams = .035 ounce  
 1 dekagram = 10 grams = .35 ounce  
 1 hectogram = 10 dekagrams = 3.52 ounces  
 1 kilogram = 10 hectograms = 2.2 pounds  
 1 quintal = 100 kilograms = 220.46 pounds  
 1 metric ton = 10 quintals = 1.1 short tons

### *Liquid Measure*

1 centiliter = 10 milliliters = .34 fl. ounce  
 1 deciliter = 10 centiliters = 3.38 fl. ounces  
 1 liter = 10 deciliters = 33.81 fl. ounces  
 1 dekaliter = 10 liters = 2.64 gallons  
 1 hectoliter = 10 dekaliters = 26.42 gallons  
 1 kiloliter = 10 hectoliters = 264.18 gallons

### *Square Measure*

1 sq. centimeter = 100 sq. millimeters = .155 sq. inch  
 1 sq. decimeter = 100 sq. centimeters = 15.5 sq. inches  
 1 sq. meter (centare) = 100 sq. decimeters = 10.76 sq. feet  
 1 sq. dekameter (are) = 100 sq. meters = 1,076.4 sq. feet  
 1 sq. hectometer (hectare) = 100 sq. dekameters = 2.47 acres  
 1 sq. kilometer = 100 sq. hectometers = .386 sq. mile

### *Cubic Measure*

1 cu. centimeter = 1000 cu. millimeters = .06 cu. inch  
 1 cu. decimeter = 1000 cu. centimeters = 61.02 cu. inches  
 1 cu. meter = 1000 cu. decimeters = 35.31 feet

## Approximate Conversion Factors

<i>To change</i>	<i>To</i>	<i>Multiply by</i>	<i>To change</i>	<i>To</i>	<i>Multiply by</i>
inches	centimeters	2.540	ounce-inches	newton-meters	.007062
feet	meters	.305	centimeters	inches	.394
yards	meters	.914	meters	feet	3.280
miles	kilometers	1.609	meters	yards	1.094
square inches	square centimeters	6.451	kilometers	miles	.621
square feet	square meters	.093	square centimeters	square inches	.155
square yards	square meters	.836	square meters	square feet	10.764
square miles	square kilometers	2.590	square meters	square yards	1.196
acres	square hectometers	.405	square kilometers	square miles	.386
cubic feet	cubic meters	.028	square hectometers	acres	2.471
cubic yards	cubic meters	.765	cubic meters	cubic feet	35.315
fluid ounces	milliliters	29.573	cubic meters	cubic yards	1.308
pints	liters	.473	milliliters	fluid ounces	.034
quarts	liters	.946	liters	pints	2.113
gallons	liters	3.785	liters	quarts	1.057
ounces	grams	28.349	liters	gallons	.264
pounds	kilograms	.454	grams	ounces	.035
short tons	metric tons	.907	kilograms	pounds	2.205
pound-feet	newton-meters	1.356	metric tons	short tons	1.102
pound-inches	newton-meters	.11296			

## Temperature (Exact)

_F	Fahrenheit temperature	5/9 (after subtracting 32)	Celsius temperature	_C
----	---------------------------	-------------------------------	------------------------	----

**PIN: 068200-000**